

DOCUMENT RESUME

ED 462 789

EC 308 855

AUTHOR Fresen, Sue, Ed.; Goldstein, Jeren, Ed.
 TITLE English I. Teacher's Guide [and Student Workbook]. Revised. Parallel Alternative Strategies for Students (PASS).
 INSTITUTION Leon County Schools, Tallahassee, FL. Exceptional Student Education.
 SPONS AGENCY Florida State Dept. of Education, Tallahassee. Bureau of Instructional Support and Community Services.
 REPORT NO ESE-305185.A; ESE-305185.B
 PUB DATE 1998-00-00
 NOTE 458p.; Course No. 1001310. Developed through the Curriculum Improvement Project. Funded under the Individuals with Disabilities Education Act (IEEA), Part B. Adapted from "English Skills I." See ED 294 245 for earlier edition.
 AVAILABLE FROM Florida State Dept. of Education, Div. of Public Schools and Community Education, Bureau of Instructional Support and Community Services, Turlington Bldg., Room 628, 325 West Gaines St., Tallahassee, FL 32399-0400 (Teacher's guide, \$3.95; student workbook, \$10.25). Tel: 800-342-9271 (Toll Free); Tel: 850-488-1879; Fax: 850-487-2679; Web site: <http://www.leon.k12.fl.us/public/pass>.
 PUB TYPE Guides - Classroom - Learner (051) -- Guides - Classroom - Teacher (052)
 EDRS PRICE MF01/PC19 Plus Postage.
 DESCRIPTORS *Academic Accommodations (Disabilities); Academic Standards; Capitalization (Alphabetic); Curriculum; *Disabilities; *English Instruction; *Grammar; Inclusive Schools; Instructional Materials; Learning Problems; Literature; Oral Language; Punctuation; *Reading Comprehension; Remedial Instruction; Secondary Education; Social Studies; State Curriculum Guides; Teaching Guides; Teaching Methods; Textbooks; Units of Study; Vocabulary Development; World Wide Web; *Writing (Composition); Writing Processes; Writing Skills
 IDENTIFIERS *Florida

ABSTRACT

This teacher's guide and student workbook are part of a series of content-centered packages of supplemental readings, activities, and methods adapted for secondary students who have disabilities and other students with diverse learning needs. Parallel Alternative Strategies for Students (PASS) materials are designed to help those students succeed in regular education content courses. The content in PASS differs from standards textbooks and workbooks in several ways: simplified text, smaller units of study, reduced vocabulary level, increased frequency of drill and practice exercises, less cluttered format, and presentation of skills in small, sequential steps. The material is designed to supplement state-adapted textbooks and other instructional materials. Both texts correlate to Florida's Sunshine State Standards and are divided into the following six units of study: (1) reading; (2) writing; (3) taking a second look at writing; (4) listening, viewing, and speaking; (5) literature; and (6) integrating online technology. For each unit, the teacher's guide includes a description of the unit's content and the unit's focus, provides suggestions

for enrichment, and contains an assessment to measure student performance. Appendices in the guide contain strategies to facilitate inclusion, a suggested list of the 500 most frequently occurring words on the Scholastic Aptitude Tests, and a chart describing standards and benchmarks. The student workbook contains vocabulary, an explanation of the content, and practice exercises designed to evaluate comprehension. (Contains 33 references.) (CR)

English I

Teacher's Guide [and Student Workbook] Revised

Parallel Alternative Strategies for Students (PASS)

Editors

Sue Fresen

Jeren Goldstein

U.S. DEPARTMENT OF EDUCATION
Office of Educational Research and Improvement
EDUCATIONAL RESOURCES INFORMATION
CENTER (ERIC)

This document has been reproduced as received from the person or organization originating it.

Minor changes have been made to improve reproduction quality.

• Points of view or opinions stated in this document do not necessarily represent official OERI position or policy.

PERMISSION TO REPRODUCE AND DISSEMINATE THIS MATERIAL HAS BEEN GRANTED BY

A. M. Duncan

TO THE EDUCATIONAL RESOURCES INFORMATION CENTER (ERIC)

1

SCOPE OF INTEREST NOTICE

The ERIC Facility has assigned this document for processing to:

EC

In our judgment, this document is also of interest to the Clearinghouses noted to the right. Indexing should reflect their special points of view.

CS

English I

Course No. 1001310



Teacher's Guide

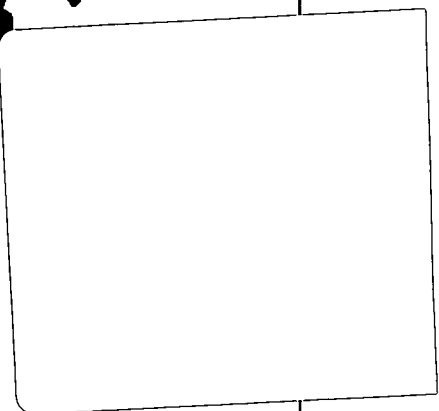

Bureau of Instructional Support and Community Services
Division of Public Schools and Community Education
Florida Department of Education
1998

Parallel
Alternative
Strategies for
Students

EC 308855

This is one of many publications available through the Bureau of Instructional Support and Community Services, Florida Department of Education, designed to assist school districts, state agencies which support educational programs, and parents in the provision of special programs. For additional information on this publication, or for a list of available publications, contact the Clearinghouse Information Center, Bureau of Instructional Support and Community Services, Division of Public Schools and Community Education, Florida Department of Education, Room 622 Turlington Bldg., Tallahassee, Florida 32399-0400 (telephone: (850) 488-1879; FAX: (850) 487-2679; Suncom: 278-1879; e-mail: duncana@mail.doe.state.fl.us).



PASS Book Evaluation Form

PASS Volume Title: _____ Date: _____
 Your Name: _____ Your Position: _____
 School: _____
 School Address: _____

Directions: We are asking for your assistance in clarifying the benefits of using the PASS book as a supplementary text. After using the PASS book with your students, please respond to all the statements in the space provided; use additional sheets if needed. Check the appropriate response using the scale below. Then, remove this page, fold so the address is facing out, attach postage, and mail. Thank you for your assistance in this evaluation.

Content

- | | Strongly Agree | Agree | Neutral | Disagree | Strongly Disagree |
|--|--------------------------|--------------------------|--------------------------|--------------------------|--------------------------|
| 1. The content provides appropriate modifications, accommodations, and/or alternate learning strategies for students with special needs. | <input type="checkbox"/> | <input type="checkbox"/> | <input type="checkbox"/> | <input type="checkbox"/> | <input type="checkbox"/> |
| 2. The content is at an appropriate readability level. | <input type="checkbox"/> | <input type="checkbox"/> | <input type="checkbox"/> | <input type="checkbox"/> | <input type="checkbox"/> |
| 3. The content is up-to-date. | <input type="checkbox"/> | <input type="checkbox"/> | <input type="checkbox"/> | <input type="checkbox"/> | <input type="checkbox"/> |
| 4. The content is accurate. | <input type="checkbox"/> | <input type="checkbox"/> | <input type="checkbox"/> | <input type="checkbox"/> | <input type="checkbox"/> |
| 5. The content avoids ethnic and gender bias. | <input type="checkbox"/> | <input type="checkbox"/> | <input type="checkbox"/> | <input type="checkbox"/> | <input type="checkbox"/> |

Presentation

- | | | | | | |
|---|--------------------------|--------------------------|--------------------------|--------------------------|--------------------------|
| 6. The writing style enhances learning. | <input type="checkbox"/> | <input type="checkbox"/> | <input type="checkbox"/> | <input type="checkbox"/> | <input type="checkbox"/> |
| 7. The text format and graphic design enhance learning. | <input type="checkbox"/> | <input type="checkbox"/> | <input type="checkbox"/> | <input type="checkbox"/> | <input type="checkbox"/> |
| 8. The practice/application activities are worded to encourage expected response. | <input type="checkbox"/> | <input type="checkbox"/> | <input type="checkbox"/> | <input type="checkbox"/> | <input type="checkbox"/> |
| 9. Key words are defined. | <input type="checkbox"/> | <input type="checkbox"/> | <input type="checkbox"/> | <input type="checkbox"/> | <input type="checkbox"/> |
| 10. Information is clearly displayed on charts/graphs. | <input type="checkbox"/> | <input type="checkbox"/> | <input type="checkbox"/> | <input type="checkbox"/> | <input type="checkbox"/> |

Student Benefits

- | | | | | | |
|---|--------------------------|--------------------------|--------------------------|--------------------------|--------------------------|
| 11. The content increases comprehension of course content. | <input type="checkbox"/> | <input type="checkbox"/> | <input type="checkbox"/> | <input type="checkbox"/> | <input type="checkbox"/> |
| 12. The content improves daily grades and/or tests scores. | <input type="checkbox"/> | <input type="checkbox"/> | <input type="checkbox"/> | <input type="checkbox"/> | <input type="checkbox"/> |
| 13. The content increases mastery of the standards in the course. | <input type="checkbox"/> | <input type="checkbox"/> | <input type="checkbox"/> | <input type="checkbox"/> | <input type="checkbox"/> |

Usage

The simplified texts of PASS are designed to be used as an additional resource to the state-adopted text(s). Please check the ways you have used the PASS books. Feel free to add to the list:

- | | |
|---|--|
| <input type="checkbox"/> additional resource for the basic text | <input type="checkbox"/> outside assignment |
| <input type="checkbox"/> pre-teaching tool (advance organizer) | <input type="checkbox"/> individual contract |
| <input type="checkbox"/> post-teaching tool (review) | <input type="checkbox"/> self-help modules |
| <input type="checkbox"/> alternative homework assignment | <input type="checkbox"/> independent activity for drill and practice |
| <input type="checkbox"/> alternative to a book report | <input type="checkbox"/> general resource material for small or large groups |
| <input type="checkbox"/> extra credit | <input type="checkbox"/> assessment of student learning |
| <input type="checkbox"/> make-up work | <input type="checkbox"/> other uses: _____ |

Overall

Strengths:

Limitations:

Other comments:

Directions: Check each box that is applicable.

- I have daily access at school to: A computer A printer The Internet A CD-ROM drive
- All of my students have daily access at school to: A computer A printer The Internet A CD-ROM drive
- I would find it useful to have PASS on: The Internet CD-ROM Mac PC/IBM

Fold Here

Fold Here

Place Stamp
Here
Post Office
Will Not
Deliver
Without
Postage

Arlene Duncan, Program Director
BISCS Clearinghouse
Turlington Building, Room 622
325 West Gaines Street
Tallahassee, FL 32399-0900

Please Tape here—Do Not Staple

English I Teacher's Guide

Course No. 1001310

**Bureau of Instructional Support and Community Services
Division of Public Schools and Community Education
Florida Department of Education**

1998

This product was developed by Leon County Schools, Exceptional Student Education Department, through the Curriculum Improvement Project, funded by the State of Florida, Department of Education, Division of Public Schools and Community Education, Bureau of Instructional Support and Community Services, through federal assistance under the Individuals with Disabilities Education Act (IDEA), Part B.

Copyright
State of Florida
Department of State
1998

Authorization for reproduction is hereby granted to the State System of Public Education as defined in Section 228.041(1), Florida Statutes. No authorization is granted for distribution or reproduction outside the State System of Public Education without prior approval in writing.

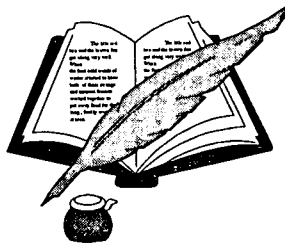

English I Teacher's Guide

Course No. 1001310

adapted from
English Skills I
Revised Edition

edited by
Sue Fresen
Jeren Goldstein

graphics by
Rachel McAllister

Curriculum Improvement Project
IDEA, Part B, Special Project



Exceptional Student Education

Curriculum Improvement Project

Sue Fresen, Project Manager

Exceptional Student Education (ESE)

Ward Spisso, Director of Exceptional Education and Student Services

Diane Johnson, Director, Florida Diagnostic Learning Resources System (FDLRS)
Miccosukee

School Board of Leon County

J. Scott Dailey, Chair

Donna Harper

Maggie Lewis

Fred Varn

Tom Young

Superintendent of Leon County Schools

William J. Montford

Table of Contents

Acknowledgments	vii
Foreword	ix
User's Guide	xi
Unit 1: Reading—Becoming a Word Detective	
Overview	1
Suggestions for Teaching	3
Unit Assessment	5
Keys	13
Unit 2: Writing—Making Words Speak	
Overview	19
Suggestions for Teaching	21
Unit Assessment	22
Keys	25
Unit 3: Writing—Taking a Second Look	
Overview	27
Suggestions for Teaching	29
Unit Assessment	30
Keys	33
Unit 4: Listening, Viewing, Speaking—Communicating Face-to-Face	
Overview	39
Suggestions for Teaching	42
Unit Assessment	47
Keys	51
Unit 5: Literature—Discovering the World, Discovering Ourselves	
Overview	53
Suggestions for Teaching	55
Unit Assessment	67
Keys	71

Unit 6: Integrating Online Technology—Using the Information Highway

Overview 75
Suggestions for Teaching 78
Unit Assessment 79
Keys 81

Appendices

Appendix A: Accommodations/Modifications for Inclusion 85
Appendix B: SAT Vocabulary Word List 89
Appendix C: Correlation to Sunshine State Standards 93
Appendix D: References 99

Acknowledgments

The *Parallel Alternative Strategies for Students (PASS)* volume *English I Teacher's Guide*, was adapted from the *PASS* volume *English Skills I Teacher's Guide*, which was produced in 1994 by Sylvia Walford, Melanie P. Humble, Portia R. Thomas, and Blanche Blank. A change in the direction for state level curriculum frameworks that support Florida's System of School Improvement and Accountability necessitated the revision. The format, text, and graphics of *English I Teacher's Guide* were designed and produced by the Curriculum Improvement Project staff and copy edited by Jeren Goldstein, PagePerfect.

Production Staff

Sue Fresen, Project Manager
Blanche Blank, Text Design Specialist
Rachel McAllister, Graphic Design Specialist
Curriculum Improvement Project
Leon County Schools
Tallahassee, FL

Foreword

Parallel Alternative Strategies for Students (PASS) books are content-centered packages of alternative methods and activities designed to assist secondary teachers to meet the needs of students of various achievement levels in the basic education content courses. Each *PASS* offers teachers supplementary activities and strategies to assist students with exceptionalities and diverse learning needs.

The alternative methods and activities found in the *PASS* materials have been adapted to meet the needs of students with diverse learning needs or other exceptionalities and are included in content classes. The *PASS* materials provide basic education teachers and exceptional education teachers with a modified approach for presenting the course content.

The content in *PASS* differs from standard textbooks and workbooks in several ways: simplified text; smaller units of study; reduced vocabulary level; increased frequency of drill and practice; concise directions; less cluttered format; and presentation of skills in small, sequential steps.

As material to augment the curriculum for students with exceptionalities and diverse learning needs, *PASS* may be used in a variety of ways. For example, some infusion strategies for incorporating this text into the existing program are as follows:

- additional resource to the basic text
- pre-teaching tool (advance organizer)
- post-teaching tool (review)
- alternative homework assignment
- alternate to a book report
- extra credit
- make-up work
- outside assignment
- individual contract
- self-help modules
- independent activity for drill and practice
- general resource material for small or large groups
- assessment of student learning

The initial work on *PASS* materials was done in Florida through Project IMPRESS, an Education of the Handicapped Act (EHA), Part B, project funded to Leon County Schools from 1981–1984. Four sets of modified content materials called *Parallel Alternate Curriculum (PAC)* were disseminated as parts two through five of *A Resource Manual for the Development and Evaluation of Special Programs for Exceptional Students, Volume V-F: An Interactive Model Program for Exceptional*

Secondary Students. Project IMPRESS patterned the *PACs* after the curriculum materials developed at the Child Service Demonstration Center at Arizona State University in cooperation with Mesa, Arizona, Public Schools.

A series of 19 *PASS* volumes was developed by teams of regular and special educators from Florida school districts who volunteered to participate in the EHA, Part B, Special Project, Improvement of Secondary Curriculum for Exceptional Students. This project was funded by the Florida Department of Education, Bureau of Education for Exceptional Students, to Leon County Schools during the 1984 through 1988 school years. Basic education subject area teachers and exceptional education teachers worked cooperatively to write, pilot, review, and validate the curriculum packages developed for the selected courses.

Continuation efforts have been maintained through the Curriculum Improvement Project. Beginning in 1989 the Curriculum Improvement Project contracted with Evaluation Systems Design, Inc., to design a revision process for the 19 *PASS* volumes. First, a statewide survey was disseminated to teachers and administrators in the 67 school districts to assess the use of and satisfaction with the *PASS* volumes. Teams of experts in instructional design and teachers in the content area and in exceptional education then carefully reviewed and revised each *PASS* volume according to the instructional design principles recommended in the recent research literature.

Neither the content nor the activities are intended to be a comprehensive presentation of any course. These *PASS* materials, designed to supplement textbooks and other instructional materials, should not be used alone. Instead, they should serve as a stimulus for the teacher to design alternative strategies for teaching the Sunshine State Standards to the mastery level to the diverse population in a high school class.

The *PASS* provides some of the print modifications necessary for students with diverse learning needs to have successful classroom experiences. To increase student learning, these materials must be supplemented with additional resources that offer visual and auditory stimuli, including computer software, videotapes, audiotapes, and laser videodiscs.

User's Guide

The *English I PASS* and accompanying teacher's guide are designed as supplementary resources for teachers who are teaching English to secondary students of various achievement levels and diverse learning needs. The contents of the *English I PASS* book is based on the *Florida Curriculum Framework* and correlate to the Sunshine State Standards.

The Sunshine State Standards are made up of *strands, standards, and benchmarks*. A *strand* is the most general type of information and is a label for a category of knowledge. The five language arts strands are Reading; Writing; Listening, Viewing, Speaking; Language; and Literature. A *standard* is a description of general expectations regarding knowledge and skill development. A *benchmark* is the most specific level of information and is a statement of expectations about student knowledge and skills. Correlation information for *English I*, course number 1001310, is given for each unit in a chart in the *Teacher's Guide* following the overview and in a correlation matrix in Appendix C.

The *English I PASS* is divided into six units of study which correspond to the Language Arts Strands. The content focuses on concepts, instructional text, and activities that promote learner expectations as identified in the course description. Each unit culminates with an application for students to demonstrate learning. These demonstrations of student learning provide the means for teachers to assess student performance.

The *Teacher's Guide* includes the following components.

- **Suggestions for Teaching and Unit Assessments:** Teachers are encouraged to provide additional practice or alter suggested practices and applications. Teachers are encouraged to interest and motivate students by relating concepts to real-world experiences and prior knowledge. It is also suggested that expectations for student performance be shared with the students before instruction begins.
- **Keys:** An answer key is provided at the end of each unit for each practice and application in the student book and for the unit assessments in the *Teacher's Guide*.
- **Appendices:** **Appendix A** contains suggested accommodations and/or modifications of specific strategies for inclusion of students with exceptionalities and diverse learning needs. The strategies may be tailored to meet the needs of students.

Appendix B is a suggested list of the 500 most frequently occurring words on the *Scholastic Aptitude Test (SAT)*. **Appendix C** contains a unit correlation chart of the Sunshine State Standards and Benchmarks for *English I* and may be used in a planbook to record the dates as the benchmarks are addressed. **Appendix D** is a list of reference materials and software used to produce *English I*.

English I is designed to correlate classroom practices with the Florida Curriculum Frameworks. No one text can adequately meet all the needs of all students—this *PASS* is no exception. It is recommended that teachers use *PASS* with other instructional strategies to aid comprehension and provide reinforcement.



Unit 1: Reading—Becoming a Word Detective

Overview

We are bombarded daily with things to read—billboards, directories, newspapers, stories, advertisements, etc. Regardless of your life's work or leisure activities, being a good reader is very important. Good readers do more than pronounce words. They use various strategies to help them understand the meaning of what they are reading, evaluate what they are reading, and find specific information in various written resources.

In this unit you will practice and apply reading strategies effectively to understand and use a wide range of technical, informative, and literary texts. The unit starts with previewing because previewing is the first thing that good readers do. It is helpful to all readers to get an overview of the material they are going to read before they start to read. The unit continues with lessons on the skills needed to understand the meaning of written words in literary texts and of visual references such as charts, graphs, and directories.

The next section of this unit provides practice in finding and understanding information. A flow chart is included that identifies particular kinds of information and corresponding resources. This section ends with an application that asks you to find information that answers a list of questions. You may be surprised at some of the answers you find when completing this information scavenger hunt.

After you have learned to make sense of the words and symbols on a page, the next step is to turn your reading into forms that fit your needs. One useful form, especially to the student, is a summary. This unit will guide you through the skills you need to produce a written summary.

Many of the things you read are written by people who hope to convince you that one idea or product is better than another. Good readers are able to evaluate what they are reading so they can make good choices in their daily lives. Therefore, the final section provides a list of questions to ask when evaluating something you are reading. At the end of this unit you will be asked to evaluate two editorials that are written on the same topic. This project will help you demonstrate many of the skills you will develop as you progress through this unit.



The chart below lists the *Sunshine State Standards: Language Arts* and corresponding benchmarks addressed in this unit.

Curriculum Framework: Standards and Benchmarks

- **Use reading strategies effectively to construct meaning from a range of technical, informative, and literary texts.**

- LA.A.1.4.1 Select and use prereading strategies that are appropriate to the text, such as discussion, making predictions, brainstorming, generating questions, and previewing to anticipate content, purpose, and organization of a reading selection.
- LA.A.1.4.2 Select and use strategies to understand words and text, and to make and confirm inferences from what is read, including interpreting diagrams, graphs, and statistical illustrations.
- LA.A.1.4.3 Refine vocabulary for interpersonal, academic, and workplace situations, including figurative, idiomatic, and technical meanings.
- LA.A.1.4.4 Apply a variety of response strategies, including rereading, note taking, summarizing, outlining, writing a formal report, and relating what is read to his or her own experiences and feelings.
- LA.A.2.4.1 Determine the main idea and identify relevant details, methods of development, and their effectiveness in a variety of types of written material.
- LA.A.2.4.2 Determine the author's purpose and point of view and their effects on text.
- LA.A.2.4.4 Locate, gather, analyze, and evaluate written information for a variety of purposes, including research projects, real-world tasks, and self-improvement.
- LA.A.2.4.6 Select and use appropriate study and research skills and tools according to the type of information being gathered or organized, including almanacs, government publications, microfiche, news sources, and information services.
- LA.A.2.4.7 Analyze the validity and reliability of primary source information and use the information appropriately.
- LA.A.2.4.8 Synthesize information from multiple sources to draw conclusions.

- **Demonstrate understanding and use of appropriate language for effective visual, oral, and written communication.**

- LA.D.2.4.2 Understand the subtleties of literary devices and techniques in the comprehension and creation of communication.

- **Demonstrate understanding of the impact of mass media and the regulations that govern its use.**

- LA.D.2.4.5 Critically analyze specific elements of mass media with regard to the extent to which they enhance or manipulate information.



Suggestions for Teaching

1. Ask students to rewrite a reading selection in as few words as possible. They should eliminate all but the main idea or the barest bones of the plot. The students could elect a winner—the best, shortest retold article or story. Alternatively, students could extract the main idea or plot and illustrate it with a different story.
2. Take a fiction or nonfiction tale and transfer it to index cards. Each index card should contain one vital element to the tale. Each student then receives one index card. You can either give the students a problem to solve based on the tale (who was the murderer, what caused the epidemic, etc.) or ask them to reassemble the tale in the correct order of events. Mysteries are excellent sources for this activity because students must inevitably answer the “W” questions.
3. Give simple cause and effect questions. When students have grasped the answers satisfactorily, increase the difficulty of the questions until you are presenting them with debatable issues. What causes student apathy? What are the effects of steroids? Perhaps you could even tackle the old “chicken and the egg” question with rewards for the most creative theory. Centering journal questions around the causes and effects of their own personal decisions can also expand their perspective on this skill.
4. Bring in actual directions to analyze in class. Ask students to invent games and then write the directions. Any exercise with directions is most effective when an actual task ensues. If you have access to a kitchen, directions for cooking can be tested, often with hilarious results. It is important to follow this activity with rewriting. Require rewrites until the directions are clear and complete. Assign students various audiences for their directions, then role-play each audience. For example, ask a student to write directions to the school for a foreign tourist or a small child. Students who attempt to follow the directions would then role-play the tourist and the child.
5. Illustrate the use of facts and opinions in advertising aimed at the teenage consumer. Most ninth grade students are just beginning to flex their buying power. At the same time, they are very influenced by peers and the media. Analyze the marketing of clothes, sports equipment, and items that are popular. Analyze claims in advertising



by researching the facts. Follow this up with an article in the school paper or even a letter to companies who students feel manipulate the facts.

6. Enlist the help of your school resource officer to surprise the class with a mock enactment of a crime or dramatic incident. Ask the class to write down the facts they noted about the incident. The school resource officer can then analyze these facts and explain which ones are useful and which ones are really opinions. For example, one student might say a small man ran by. Upon further reflection, the actor could return and a more factual description be given.
7. Use magazine and newspaper articles to teach fundamental reading comprehension skills. Often textbook articles for exceptional students are overly simplistic in style and dated in content. Popular magazines seldom write above an eighth grade level, but cover more relevant issues.



Unit Assessment

Main Idea

Read the following passage to determine the **main idea**. Answer the questions below with short answers.

Some proverbs are repeated so often that they become meaningless. However, proverbs become proverbs because they contain common wisdom. You've probably heard the proverb *don't judge a book by its cover* many times. When you go to a book store and buy a book, you don't sit down and read it; you look at the cover. The more fantastic the cover illustrations, the more likely you are to fish out your wallet. But haven't you ever been seduced by a book cover only to find the contents boring? Or perhaps you've found a book printed before book covers were illustrated and found that underneath the dust was a brilliant, gripping story. People really are like books. Clothes, jewelry, name-brand sneakers, even skin color is all part of our cover. The flashiest guy may secretly be insecure or intellectual. The plainest old woman may have once been a famous jazz musician. People you've been taught to hate may actually be quite like you on the inside. The point is, if you judge a book by its cover, you may miss out on an enriching, enlightening experience. So leaf through the pages of someone's mind and encourage others to do the same with you.

1. What is the main idea of this paragraph? _____

2. Which sentence from the paragraph best expresses the main idea?



The "W" Questions

Read the following passage to answer the "W" questions (who, what, when, where, why, which, how). Then answer the questions below using complete sentences.

Diane Ackerman is a naturalist. In her book *The Moon by Whale Light*, she studies alligators, penguins, whales, and bats. She sails around the sub-Antarctic islands to look at penguins in the wild. Unfortunately, early European visitors killed penguins from these islands to make oil. Today pesticides such as DDT are hurting the penguins. Besides informing us of the importance of conservation after such a tragic history, Ms. Ackerman also recounts some humorous stories. For example, she hears a sound like a gunshot while visiting the island. She asks a scientist what it is. He explains that the sound could have been an exploding egg. He said that sometimes rotten eggs become explosive and a very surprised penguin finds that his egg has blown up right under him. As you can see, a naturalist's life is never dull.

3. Who is Diane Ackerman? _____

4. What are the subjects of her book *The Moon by Whale Light*? _____

5. Where does Ackerman go to see penguins in the wild? _____

6. Why did early European visitors kill penguins? _____

7. Which pesticide does Ackerman mention specifically? _____



8. *How* does Stonehouse explain the gunshot noise? _____

Chronological Order

9. *Read the following jumbled story. Determine the sequence of numbers that would put the story into correct **chronological order**. Then circle the correct answer at the bottom of the page.*

1. After Jill accepted, Jack put his pail in the trunk of his car.
2. While they were carrying the water, Jack tripped and fell in front of Jill.
3. After a short time, they both got up.
4. One morning Jack rang up his friend, Jill, to ask her on a date.
5. They drove to a large hill at the end of the drive from Jill's house.
6. Immediately after, Jill tripped over the fallen Jack.
7. Jack drove over to Jill's house to pick her up.
8. As soon as they got to the hill, Jack asked Jill to help him fill his pail with fresh spring water for his goldfish.
9. Finally, Jill drove home and told Jack she had never had such a lousy date and she didn't want to see him or his pail again.
10. Before they got up, Jill noticed that Jack had sustained a nasty gash on his head during his fall.
 - a. 4, 1, 7, 9, 5, 8, 2, 6, 3, 10
 - b. 2, 5, 10, 1, 6, 9, 4, 7, 3, 8
 - c. 3, 9, 2, 4, 7, 8, 5, 6, 10, 1
 - d. 4, 1, 7, 5, 8, 2, 6, 10, 3, 9



Comprehension

Read the following passage and briefly answer the questions that follow.

Sculptor Glenna Goodacre has created a statue to honor more than 11,000 U.S. military women who served in Vietnam. Diane Carlson Evans is one of these women. She was a 21-year-old nurse who served in Vietnam in 1968. After seeing the sculpture of male soldiers that was placed beside the Vietnam Memorial, Evans felt that the women should also be honored. It took 10 years before the statue was erected.* Evans fought for so long because she felt passionately about equal recognition. She also believed that future generations should come to know and to understand who these brave women were and how they felt about their difficult job. Evans hopes that female veterans will now have a place to “come home” to in Washington, D.C.

*Due to sexism and ignorance, it was difficult to raise money to build the sculpture. However, after traveling around the country to promote the project, Evans received enough donations. Former nurses, male veterans, and families who had lost sons in the war all donated money to show gratitude for the work of the nurses and women who had served during the war.

Source: *Ms Magazine* (IV. 3)

10. Why did Glenna Goodacre create a statue of U.S. military women?

11. What caused Diane Carlson Evans to want a statue of women at the Vietnam Memorial?

12. What caused a delay of 10 years before the statue was erected? _____



13. *What* motivated people to donate money to erect the statue? _____

14. *What* are two effects Evans hopes the statue will have? _____

15. *What* was the source for this information? _____

True or False

*Read the following paragraph carefully, then evaluate the statements that follow. Write **True** if the statement is correct. Write **False** if the statement is not correct.*

Snakebites

Very few people die from snakebites. However, anyone who is bitten by a snake should get medical help quickly. If Emergency Medical Service (EMS) is more than 30 minutes away, transport the victim to a medical center in another vehicle if possible. Reassure the victim and keep him or her still until medical personnel begin treatment. Keeping still will slow down absorption of the snake venom, as will keeping the bitten area below the level of the heart. If the bite is on an arm or leg, put a splint on the limb. Be alert to prevent shock. Try to remember what the snake looked like, so you can help medical personnel counteract the venom. Cold packs do not slow the spread of snake venom and applying it improperly can damage tissue. Do not give aspirin to the victim as it will circulate the venom faster.

Source: *The American Red Cross Standard First Aid Workbook* (103)



- _____ 16. If EMS is 25 minutes away, the victim should be transported to a medical center in your vehicle.
- _____ 17. The victim should move to maintain circulation.
- _____ 18. The bitten area should be kept below the heart.
- _____ 19. If the bite is on the victim's arm, that arm should be splinted.
- _____ 20. Shock can affect the victim.
- _____ 21. You should remember what the snake looked like to help medical personnel counteract the venom.
- _____ 22. A cold pack slows the spread of venom.
- _____ 23. The victim should be given aspirin for the pain.



Fact and Opinion

Identify five **opinions** and five **facts** in the political campaign ad below. List them on the lines that follow.

Kelly Delaney
 ...a family person 47 yrs. old, married to Lee, with two children and robot Spiff. YOUR kind of person!



Kelly says...

As a member of the Demopublican party, I believe that Earthlings are far, TOO VIOLENT! More than 25,000 people died from handguns last year. Over 300,000 people were homeless.

Only an **OUTSIDER** can save this planet.

Election day is NOV 5th!

VOTE for me! I can bring **PEACE** to all!

Politicians are corrupt!
 It's time for a change!
 Vote **DEMOPUBLICAN**
 on
NOV 5th!

**Voting is GOOD.
 Apathy is BAD.
 Register today!**

 This advertisement is paid for by the National Demopublican Party.

24. Facts: _____



25. Opinions: _____



Keys

Practice (pp. 10-11)

1. The general subject of this article is viruses.
The article will focus on the way in which viruses are tiny saboteurs.
Yes: the author uses the word *saboteur*, which is used to describe enemies intent on committing destruction.
2. The information is divided into the *characteristics of viruses* and *viruses and illnesses*.
Viruses have characteristics we can identify. Viruses also have a relationship to illnesses; most likely viruses are the cause and illnesses are the effect.
3. Viruses are very small, smaller than even the tiny bacteria cell.
4. The author finds viruses to be a mystery, and says so by writing: "Viruses are strange little things that don't fall into any category." The information appears to be objective; however, the author does create a subjective attitude towards the subject by using words such as *strange*, *tricks*, and *viruses are responsible*. In spite of these loaded words, the article would appear to be an explanation.
5. Viruses can be extremely serious, causing such diseases as HIV.

Application (p. 13)

Correct answers will be determined by the teacher.

Practice (p. 16)

- 1.-5. Correct answers will be determined by the teacher.

Practice (p. 17)

Dynamite and *investments* should be circled.

1. X
2. X
6. X
7. X
8. X

Practice (p. 20)

1. E.
2. H.
3. F.
4. D.
5. G.
6. C.
7. B.

Practice (p. 21)

1. reflecting or sparkling
2. pleasant or polite
3. pale
4. admire
5. rhythm
6. disinterested
7. learned or well educated
8. sophisticated
9. charming
10. shortness of time

Practice (p. 22)

1. Answers will vary.
2. Answers will vary.
3. Answers will vary.
4. Answers will vary.
5. Answers will vary.

Application (p. 23)

Correct answers will be determined by the teacher.



Keys

Practice (p. 26)

1. carry
2. respond
3. intellectual
4. change
5. nuclear
6. civilize
7. sonic
8. atmosphere
9. condition
10. realize
11. inherit
12. communicate
13. vocal
14. sense
15. organize
16. possess
17. child
18. accident
19. religious
20. difficult

Practice (p. 27)

1. before
2. against
3. two
4. not
5. across
6. out
7. not
8. not
9. between
10. wrong
11. before
12. after
13. under
14. above or beyond
15. not
16. one
17. five
18. back
19. wrong
20. again

Practice (p. 28)

1. est; smallest
2. less; thoughtless
3. ment; enticement
4. less; careless
5. ful; thankful
6. ness; willingness
7. est; shortest
8. less; hopeless
9. able; changeable
10. fold; sixfold
11. ist; motorist
12. ize; colorize
13. ly; nicely
14. en; harden
15. ize; digitize

Practice (pp. 29-30)

1. musically; musical; musician
2. interesting; interestingly; interested
3. friend; friendly; friendliness
4. farmers
5. wisdom; wiser
6. postage; posted; postal
7. Summarize; summary
8. investor; invested; investments
9. critically; critics; criticism
10. western; westward; westerly

Application (p. 31)

Answers will vary.

Practice (p. 33)

1. U
2. F
3. U
4. F
5. Answers will vary.
6. Answers will vary.
7. Answers will vary.
8. Answers will vary.



Keys

Application (p. 34)

Correct answers will be determined by the teacher.

Practice (p. 37)

1. a student and his teacher
2. a student who can master complicated computer techniques but did not do his homework
3. in the classroom
4. during class
5. The student said he did not write his essay because he did not understand the topic, but he does understand complicated computer language.
6. Both the ability to run the computer hardware and the essay's topic are complicated, as is the student's excuse.
7. A student who can master complicated techniques should be able to write an essay.

Practice (p. 40)

1. S
2. P
3. O
4. M
5. P
6. S
7. O
8. P
9. M
10. M

Application (p. 41)

Correct answers will be determined by the teacher.

Practice (p. 44)

1. Museum of Early Florida History
2. Indian artifacts

3. 698-3414
4. 101 2nd St.
5. 2

Practice (pp. 45-47)

1. b.
2. a.
3. d.
4. c.
5. d.
6. c.
7. a.
8. b.
9. a.
10. c.

Practice (p. 48)

1. Day Rate (Full Rate)
2. Saturday
3. Day Rate (Full Rate)
4. 5:00 PM and 11:00 PM
5. Evening Rate (35% Discount)

Practice (pp. 49-50)

1. a.
2. d.
3. c.
4. b.
5. c.

Practice (p. 52)

1. D.
2. E.
3. G.
4. I.
5. H.
6. C.
7. J.
8. A.
9. B.
10. F.



Keys

Practice (pp. 53-55)

1. c.
2. c.
3. d.
4. d.
5. a.
6. b.
7. c.
8. d.
9. b.
10. c.

Practice (pp. 56-57)

1. It is the contact for the operation of the flash attachment.
2. in the film cartridge chamber
3. to prevent film exposure to light when changing lenses
4. turn the film rewind system
5. the view finder
6. the normal camera lens that has one focal length and the widest aperture or opening
7. Check the film leader indicator.
8. operate camera using a remote device

Application (p. 58)

Correct answers will be determined by the teacher.

Practice (p. 61)

1. encyclopedia
2. atlas
3. newspaper
4. directory
5. dictionary
6. thesaurus or dictionary
7. newspaper
8. dictionary
9. atlas
10. thesaurus

Practice (p. 63)

1. Ch. 2
2. T. Sullivan
3. pages 17-19
4. Pollution—A Silent Killer
5. "An Environmental Hero"
6. manatee, panther, brown pelican

Practice (p. 64)

1. True
2. False
3. True
4. False
5. False

Practice (pp. 65-66)

1. b.
2. d.
3. a.
4. c.
5. a.

Application (pp. 67-69)

Correct answers will be determined by the teacher.

Practice (pp. 74-75)

Correct answers will be determined by the teacher.

Application (p. 76)

Correct answers will be determined by the teacher.

Practice (p. 79)

1. F
2. T



Keys

3. F
4. F
5. T
6. T
7. T
8. F
9. F
10. T

Application (p. 80)

Correct answers will be determined by the teacher.

Unit Assessment (TG: pp. 5-12)

1. The outward appearance of a person or thing may deceive us about what is inside.
2. The point is, if you judge a book by its cover, you may miss out on an enriching, enlightening experience.
3. Diane Ackerman is a naturalist.
4. The subjects of her book *The Moon by Whale Light* are alligators, penguins, whales, and bats.
5. Ackerman visits the sub-Antarctic islands to see penguins in the wild.
6. Early European visitors killed penguins to make oil.
7. Ackerman specifically mentions the pesticide DDT.
8. Stonehouse explains that the gunshot noise could be a rotten egg that has exploded.
9. d.
10. to honor U.S. military women who served in Vietnam.
11. seeing the sculpture of male soldiers placed beside the Vietnam Memorial
12. difficulty in raising money to build the sculpture
13. gratitude for the work of nurses and women who had served during the war
14. equal recognition for women who served in Vietnam; future generations will come to know and understand these brave women
15. *Ms Magazine*
16. False
17. False
18. True
19. True
20. True
21. True
22. False
23. False
24. Kelly Delaney is 47 years old; she is married to Lee; she has two sons; she has a robot; she is a member of the Demopublican party; more than 25,000 people died from handguns last year; over 300,000 people were homeless last year; election day is Nov. 5th; ad was paid for by National Demopublican Party.
25. Kelly Delaney is a family person; she is your kind of person; Earthlings are too violent; only an outsider can save this planet; she can bring peace to all; politicians are corrupt; it's time for a change; voting is great; apathy is bad; vote Demopublican on Nov. 5th; register today.



Unit 2: Writing—Making Words Speak

Overview

In this unit you will learn how to build on the writing skills you already have. One of the most important writing skills is shaping your writing for specific readers. Most likely, this is a skill that you have been using much of your life. For example, contrast a note you passed to a friend during class with a thank-you note you sent to a grandparent or other adult. These two notes were probably very different because the two audiences, or the readers of these documents, were very different. You may have used shorter sentences and included slang in the note to your friend. On the other hand, you may have been more careful with grammar and spelling in the letter to the adult. In each instance, you were adjusting your writing to meet the needs of your audience.

At the end of this unit you will have produced two documents on the same topic. The topic for these two documents will come from policies in your student handbook. Both of these documents will present your opinion about the policy you have selected. However, each document will be different because it will be written for a different audience.

This unit will take you through the series of steps to use when writing your document. The steps and skills that are included in this process can be used anytime you need to write anything, regardless of the topic or subject.

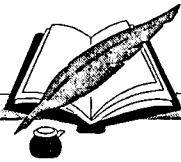

The chart below lists the *Sunshine State Standards: Language Arts* and corresponding benchmarks addressed in this unit.

Curriculum Framework: Standards and Benchmarks

- **Use reading strategies effectively to construct meaning from a range of technical, informative, and literary texts.**

LA.A.1.4.3 Refine vocabulary for interpersonal, academic, and workplace situations, including figurative, idiomatic, and technical meanings.

LA.A.1.4.4 Apply a variety of response strategies, including rereading, note taking, summarizing, outlining, writing a formal report, and relating what is read to his or her own experiences and feelings.

LA.A.2.4.5 Identify devices of persuasion and methods of appeal and their effectiveness.

- **Use process writing strategies effectively to meet the needs of a variety of audiences, writers, and types of information being communicated.**

LA.B.1.4.1 Select and use appropriate prewriting strategies, such as brainstorming, graphic organizers, and outlining.

LA.B.1.4.2 Draft and revise writing that

- is focused, purposeful, and reflects insight into the writing situation;
- has an organizational pattern that provides for a logical progression of ideas;
- has effective use of transitional devices that contribute to a sense of completeness;
- has support that is substantial, specific, relevant, and concrete;
- demonstrates a commitment to and involvement with the subject;
- uses creative writing strategies as appropriate to the purpose of the paper;
- demonstrates a mature command of language with precision of expression;
- has varied sentence structure; and
- has few, if any, convention errors in mechanics, usage, punctuation, and spelling.

LA.B.2.4.2 Organize information using appropriate systems.

LA.B.2.4.3 Write fluently for a variety of occasions, audiences, and purposes, making appropriate choices regarding style, tone, level of detail, and organization.

- **Select and use a variety of electronic media to create, revise, retrieve, and verify information.**

LA.B.2.4.1 Write text, notes, outlines, comments, and observation that demonstrate comprehension and synthesis of content, processes, and experiences from a variety of media.

LA.B.2.4.2 Organize information using appropriate systems.

- **Demonstrate understanding and use of appropriate language for effective visual, oral, and written communication.**

LA.D.2.4.2 Understand the subtleties of literary devices and techniques in the comprehension and creation of communication.



Suggestions for Teaching

1. Have students write a set of good, clear directions to guide a new student in the school from the principal's office to the cafeteria.
2. Have students use a school map to write directions to a location in the school. Exchange directions with a partner. The partner should be able to tell the intended destination. If not, the student should see at what point the partner was confused and correct the mistake by rewriting the directions. The partner should then try again.
3. Have students write two possible pieces of dialogue that could be used to enhance a narrative.
4. Have students pretend that they are the friend of a famous person whom they admire. Write a friendly letter to this person. Be sure to include all the correct parts of the letter.
5. Have students imagine they have attained their dream job. Ask them to create an application form for their job. Have someone else in the class fill it out. Creative forms and responses could be welcomed.
6. Gather together forms from businesses, the IRS, doctors' offices, insurance offices, etc. Use these actual forms in your class.
7. Ask your school secretary to "guest lecture" on writing letters and messages. Many secretaries have a wealth of knowledge and entertaining stories about this particular skill.
8. Install a message board in your room for student-to-student and teacher-to-student communication. Also begin a collection of funny and problematic messages; use them to illustrate your point.
9. Write movie and concert reviews and post them on the message board.
10. Ask students to interview their parents and grandparents about an opinion they hold strongly. Write a paragraph to support or refute this opinion. Topics relating to school and music often lead to lively cross-generational discussions.
11. Encourage students to write letters to the school board, local leaders, and state and national politicians on topics they feel strongly about. Curfews, juvenile justice, and censorship are popular issues.



Unit Assessment

1. Expository Writing

Write an expository paragraph on a subject of your choice or on a subject assigned by your teacher.

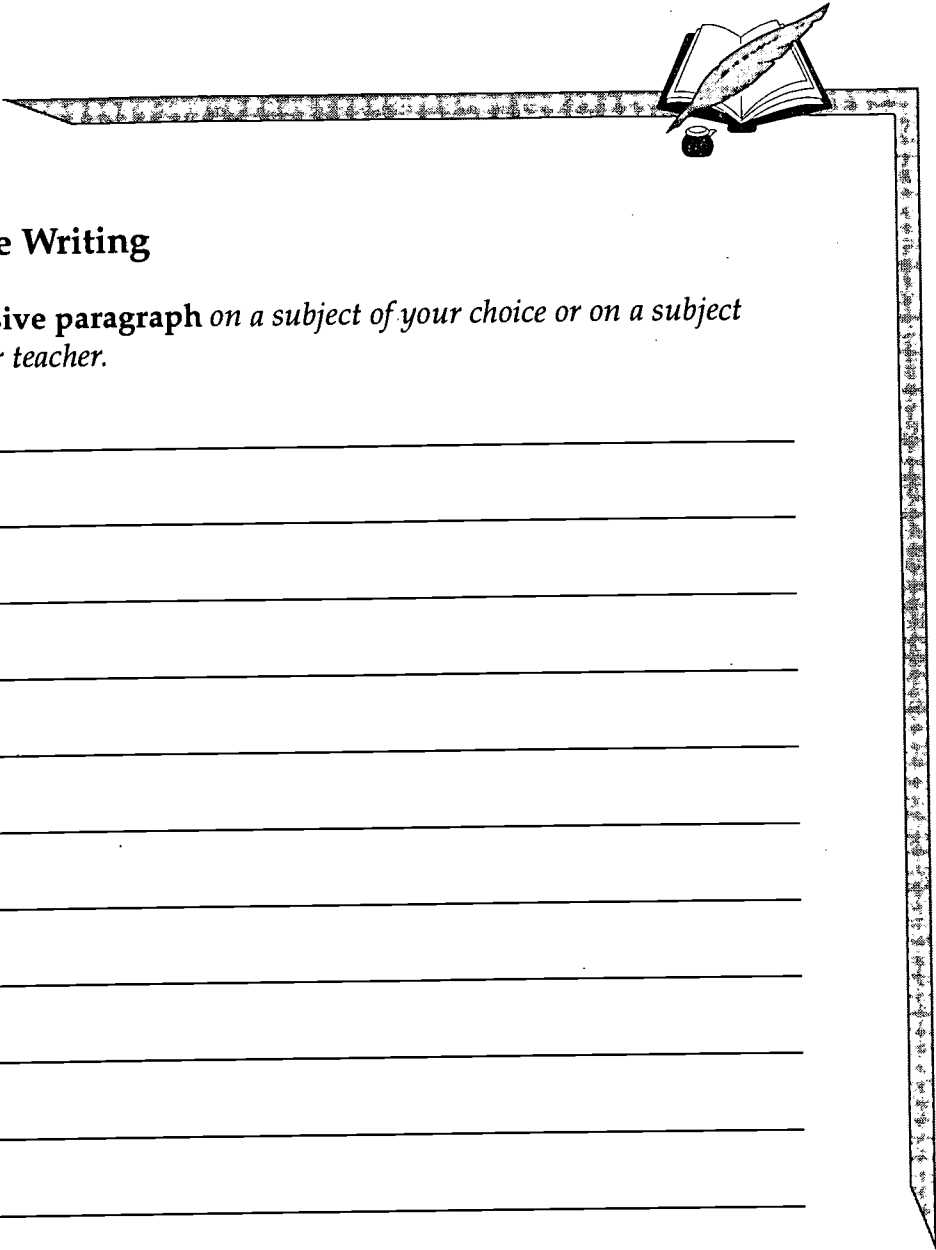

2. Persuasive Writing

Write a **persuasive paragraph** on a subject of your choice or on a subject assigned by your teacher.



Keys

Practice (p. 93)

Correct answers will be determined by the teacher.

Application (p. 94)

Correct answers will be determined by the teacher.

Practice (p. 97)

1. the "Age of Rivers"
2. young rivers; mature rivers; old rivers
3. young rivers: erode land very quickly, have rapids and waterfalls, very fast flowing; mature rivers: no longer have rapids or waterfalls, have formed wide valleys, have been developing for thousands of years; old rivers: curved and winding with loops called meanders, slow-moving water, carry small particles as they erode land

Practice (p. 98)

nine
explain
read written briefs
hear oral arguments
discuss cases and vote

Practice (p. 99)

- B. Hear oral arguments
- C. Discuss cases and vote
3. Explain decision

Application (p. 100)

Correct answers will be determined by the teacher.

Practice (p. 103)

1. b.
2. b.
3. b.
4. b.

Practice (p. 105)

1. confused
2. car
3. exited
4. clear
5. money
- 6.-10. Answers will vary.

Application (p. 106)

Correct answers will be determined by the teacher.

Practice (p. 110)

Correct answers will be determined by the teacher.

Practice (p. 111)

Correct answers will be determined by the teacher.

Practice (p. 118)

Correct answers will be determined by the teacher.

Application (p. 119)

Correct answers will be determined by the teacher.

Practice (p. 124)

1. c.
2. a.
3. d.
4. b.



Keys

Practice (p. 126)

1. census records
2. encyclopedia
3. people with experience
4. university professors
5. research reports
6. people with experience
7. encyclopedia
8. research reports

Practice (p. 127)

1. F.
2. B.
3. C.
4. J.
5. G.
6. A.
7. E.
8. H.
9. I.
10. D.

Practice (p. 128)

1. persuasive
2. persuasive
3. expository
4. persuasive
5. persuasive
6. expository
7. persuasive
8. persuasive
9. expository
10. persuasive

Application (p. 129)

Correct answers will be determined by the teacher.

Application (p. 130)

Correct answers will be determined by the teacher.

Unit Assessment (TG: pp. 22-23)

1. Correct answers will be determined by the teacher.
2. Correct answers will be determined by the teacher.

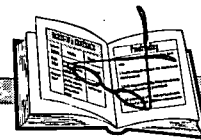

Unit 3: Writing—Taking a Second Look

Overview

In the previous unit (“Writing—Making Words Speak”) you produced two paragraphs. Although each paragraph was written to a different audience, in both paragraphs you argued for a change in your student handbook. These paragraphs are not quite finished, however. They are your first attempt to write, or “speak,” to your audiences. This first attempt to direct your writing to an audience is called a *first draft*. Think back to the last time you looked through a pair of binoculars or a microscope. Most likely, the picture you saw was a little blurred. You found, however, that by doing some fine tuning you could improve the picture until it was crystal clear. You are about to do the same thing to your first draft. You are about to fine tune your first draft so that it says exactly what you want it to say and looks exactly how you want it to look. Only after you have adjusted your paragraphs, or pictures, will your writing be ready for your readers.

The process of fine tuning your writing has three steps. The first step is called *revising*. During this step you look at what you have said and the way in which you have said it. Not until you have tuned your message are you ready for step two: *editing*. During the editing stage you check your grammar, punctuation, and spelling. Lastly, after your writing says what you intend, and uses correct English, you are ready for the final step: *proofreading*. During this step you check for typos, omitted words, misspellings, or any other “accidents” on the page. This is your final look to make sure everything is just right. When you have completed these three steps, you are ready to deliver your writing to your audience.

These three steps are used by all different levels of writers. Even professional writers don’t get it right in their very first draft. Writing is a process, and good writing has been adjusted until its message is clear, persuasive, and (nearly) error free.

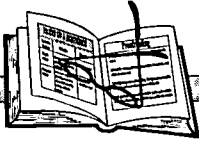

The chart below lists the *Sunshine State Standards: Language Arts* and corresponding benchmarks addressed in this unit.

Curriculum Framework: Standards and Benchmarks

- Use process writing strategies effectively to meet the needs of a variety of audiences, writers, and types of information being communicated.

LA.B.1.4.2 Draft and revise writing that

- is focused, purposeful, and reflects insight into the writing situation;
- has an organizational pattern that provides for a logical progression of ideas;
- has effective use of transitional devices that contribute to a sense of completeness;
- has support that is substantial, specific, relevant, and concrete;
- demonstrates a commitment to and involvement with the subject;
- uses creative writing strategies as appropriate to the purpose of the paper;
- demonstrates a mature command of language with precision of expression;
- has varied sentence structure; and
- has few, if any, convention errors in mechanics, usage, punctuation, and spelling.

LA.B.1.4.3 Produce final documents that have been edited for

- correct spelling;
- correct punctuation, including commas, colons, and common use of semicolons;
- correct capitalization;
- correct sentence formation;
- correct instances of possessives, subject/verb agreement, instances of noun/pronoun agreement, and the intentional use of fragments for effects; and
- correct formatting that appeals to readers, including appropriate use of a variety of graphics, tables, charts and illustrations, in both standard and innovative forms.

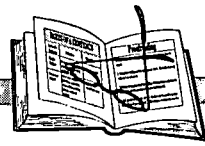

Suggestions for Teaching

1. Encourage students to use technology to help them proofread. Most software comes with spell checkers and grammar checkers. Usually, the program will require students to choose a correct replacement, so they still need to actively participate in the revisions.
2. Create a proofreading assembly line. Ask each student, or pairs of students, to proofread according to their strengths.
3. Keep a file for students on peer experts, tutors, and sources to help them proofread their work.
4. Emphasize writing and content on first and second drafts. Expect grammatical revision later in the process.
5. Award bonus points if students can bring spelling, punctuation, or grammar mistakes in the mass media to discuss in class.
6. Use examples to illustrate correct and incorrect standard English.
7. Generate spelling lists from student's work. Start with essential vocabulary and expand their spelling lists. Ask students to maintain a personal dictionary in their notebooks.
8. Give students some simple sentences and ask them to rewrite them as compound sentences. Review the use of coordinating conjunctions in writing compound sentences using the **FAN BOYS***—for, and, nor, but, or, yet, so.
9. Collect and share successful techniques with other teachers.

* The Sentence Writing Strategy (using FAN BOYS) noted in this document is based on the work of Dr. Jean B. Schumaker of the University of Kansas Center for Research on Learning (KU-CRL). This strategy is a part of the Strategic Instruction Model (SIM). To optimize student performance, teachers should first receive formal training in the use of the strategy from a certified SIM trainer. Training will be available from certified SIM trainers in the State of Florida as soon as the instructor's manual and accompanying student practice lessons are published. These materials will be available in the near future.

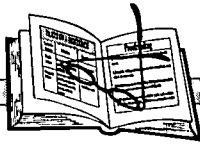

Unit Assessment

Circle the verb that agrees with the **subject** in each of the sentences below.

1. The baby (sleep, sleeps) peacefully.
2. Twins (play, plays) together all the time.
3. (Have, Has) the soccer players prepared for the game?
4. He (don't, doesn't) like video games.
5. I thought we (were, was) going to the movies tonight.
6. She (dream, dreams) of a better life.
7. Sneakers and shoes (are, is) so expensive.
8. (Do, Does) your car start in cold weather?
9. People who (read, reads) are educating themselves.
10. Some dogs (chew, chews) the furniture when they are young.

Write the correct **plural form** of each of the following nouns.

- | | | | |
|--------------|-------|-------------|-------|
| 11. knife | _____ | 15. skill | _____ |
| 12. four | _____ | 16. 1950 | _____ |
| 13. children | _____ | 17. person | _____ |
| 14. box | _____ | 18. tornado | _____ |

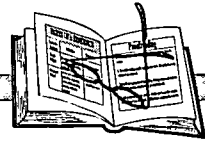

Write the correct **singular form** of each of the following **nouns**.

- | | | | |
|------------|-------|-----------|-------|
| 19. teeth | _____ | 23. sheep | _____ |
| 20. oxen | _____ | 24. mice | _____ |
| 21. leaves | _____ | 25. foxes | _____ |
| 22. ABCs | _____ | 26. wigs | _____ |

Rewrite each **incomplete sentence** or **run-on sentence** below to make a **complete sentence**.

27. Italian food is delicious most people enjoy it very much. _____

28. The cat, who was unusual because he had six toes. _____

29. After he recovered from a terrible illness. _____

30. Jumping, running, and leaping all day. _____

31. In America, religion and government are not supposed to. _____

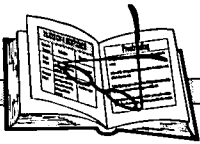

32. The paragraphs below are the first draft of the opening to an essay. They contains 30 mistakes in spelling and punctuation. Circle the errors, then rewrite the story on another piece of paper.

What causes violence in America? More importantly what are the solutions to this violance. Time and Newsweek are full of storys about young people killing one another. If something drastick doesn't happen soon we will lose to many members of our future generations. One student I interviewed said theres just nothing to look forward to" It is our job to give the next generation something to look forward to.

Creative sollutions to the following problems must be found unemployment poverty teenage pregnancy apathy and health care. All of these problems contribute to violence. One school in tallahassee plans to teach conflict resolution skills to both faculty and students. Other cominities are trying to persuade young people that its whats inside that counts not what you own. What can you do to stop the ciolence. The answers are clear become involved promote compasion instil self-discipline encourage self-worth and begin right now.

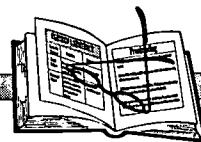

Keys

Practice (p. 148)

1. Answers will vary.
2. Answers will vary.

Practice (p. 149)

1. !-exclamatory or .-declarative
2. ?-interrogative
3. .-imperative
4. !-exclamatory or .-declarative
5. !-exclamatory or .-declarative
6. ?-interrogative
7. .-imperative
8. .-declarative
9. ?-interrogative
10. !-exclamatory or .-imperative

Practice (p. 150)

Correct answers will be determined by the teacher.

Practice (p. 152)

1. I-S
2. I-V
3. C
4. I-V
5. I-S
6. C
7. C
8. I-V

Practice (p. 153)

Correct answers will be determined by the teacher.

Practice (p. 155)

Correct answers will be determined by the teacher.

Practice (p. 156)

1. C

2. F
3. F
4. R
5. R
6. C
7. F
8. R
9. C
10. F

Practice (p. 157)

Answers will vary.

Practice (pp. 158-159)

1. c.
2. c.
3. b.
4. c.
5. d.
6. d.
7. a.
8. a.
9. b.
10. a.

Practice (p. 162)

1. creep
2. believes
3. swallow
4. is
5. sing
6. refrain
7. don't
8. expand
9. Have
10. were

Practice (p. 163)

1. trash can
2. He
3. shoes
4. They
5. an umbrella
6. twins

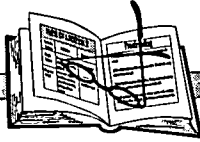

Keys

7. word
8. They
9. Apples
10. wig

Practice (p. 164)

1. A large basket; was
2. Everyone; wonders
3. Both; are
4. Some; live
5. Some; are
6. My power; is
7. Everybody; looks
8. Few; believe
9. Most; votes
10. most; wish
11. The solution; is
12. Each; has
13. Several; speak
14. All; does
15. All; think

Practice (p. 167)

1. brought; brought
2. bought; bought
3. caught; caught
4. cost; cost
5. cut; cut
6. found; found
7. heard; heard
8. held; held
9. hurt; hurt
10. left; left
11. lent; lent
12. lost; lost
13. swept; swept
14. told; told
15. taught; taught
16. understood; understood

Practice (p. 168)

	Present	Past	Past Participle
1.		became	become
2.	come		come
3.	begin	began	
4.		did	done
5.	fly		flown
6.	grow	grew	
7.		knew	known
8.	ride		ridden
9.	see	saw	
10.		shook	shaken
11.	read	read	
12.	steal		stolen
13.		threw	thrown
14.	wear		worn
15.	write	wrote	
16.		took	taken
17.	sing	sang	
18.		taught	taught
19.	shake	shook	
20.		spoke	spoken

Practice (p. 169)

I first became aware that something was odd about him when he stepped from his spaceship. He told me he had ridden his spaceship to Earth from another galaxy. At first I did not believe him. I began to get suspicious when he drank soda and ate pizza like a pro. After he had eaten, he asked for a muffin for dessert. I thought for sure he was just an earthling on a highly secret Air Force mission. But then he boarded his spaceship and flew away at warp speed. It was not until I saw (*or had seen*) him disappear in a flash that I realized I had just spent an evening with an alien.

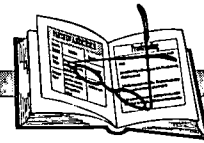

Keys

Practice (p. 172)

1. trees
2. fish
3. rubies
4. toys
5. lives
6. reefs
7. radios
8. tornadoes
9. children
10. sheep
11. 1960s
12. twos
13. sacks
14. dishes
15. wives
16. backgrounds
17. 6s
18. people
19. mice
20. families
21. ladies
22. Ds or D's
23. torpedoes
24. mother-in-law
25. Susans
26. classes
27. hopes
28. beliefs
29. smiles
30. ditches

Practice (p. 173)

1. blurds
2. shinexes
3. croys
4. vixives
5. seos
6. jehnoes
7. uxen
8. gluchnies
9. thrans-in-law
10. noiloes

Practice (pp. 174-175)

1. box
2. cat
3. pony
4. brush
5. dairy
6. dress
7. assembly
8. life
9. goose
10. calf
11. base
12. file
13. bead
14. bike
15. paper
16. elf
17. beach
18. body
19. inch
20. chain
21. shirt
22. bottle
23. flower
24. wax
25. state
26. pick
27. book
28. concert
29. buddy
30. plane
31. ear
32. city
33. trail
34. face
35. agency
36. witness
37. leaf
38. lie
39. witch
40. mess
41. switch
42. activity
43. skate
44. year
45. team
46. change

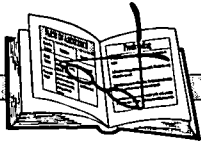

Keys

47. second
48. wing
49. cry
50. strike

Practice (p. 176)

1. man
2. child
3. city
4. bus
5. map
6. person
7. gallery
8. woman
9. deer
10. sister-in-law

Practice (p. 177)

1. art historians
2. addresses
3. 1950s
4. fishes
5. wishes
6. radios
7. knives
8. halves
9. Centuries

Practice (p. 181)

1. She
2. They
3. He
4. It
5. they
6. It
7. He or she
8. He
9. he
10. he or she

Practice (p. 184)

1. girl's sandwich
2. book's pages
3. boy's model airplanes

4. boy's toys
5. children's sandbox
6. cats' tails
7. women's tools
8. student's absences; student's story
9. student's adventures; school's hallways
10. townspeople's laughter
11. My car
12. Their house
13. Our house
14. His house
15. Its doghouse

Practice (pp. 188-189)

1. Gainesville
3. Tammy
4. Canada
5. NY Giants
7. Malcolm
8. J.C. Penny
9. Dairy Queen
12. Easter
13. January
15. Dr. Chin
17. Spanish
18. Muslim
19. Tampa
20. Elm Street

Practice (p. 190)

Words to be circled are: Maya Angelou, African American, She, Arkansas, United States, Her, Ms. Angelou, I Know Why Caged Bird Sings, William Shakespeare, Today, Shakespeare, Angelou, English, In, Maya Angelou, Ladies Home Journal, Woman, Year, Award, She, Wake Forest University, She, President Clinton.

Practice (p. 193)

1. Flowers for Algernon
2. Newsweek; "Steroids and

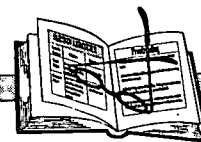

Keys

- Teenagers"
3. Modern Poetry
 4. The Thinker
 5. The Autobiography of Malcolm X: Malcolm X
 6. "Where are you going tonight?"
 7. "Help!"
 8. Ghost Writer
 9. "Happy Father's Day!"
 10. 'I name this ship Elizabeth."

Practice (p. 194)

1. chocolate, kiwi fruit,
2. gentle, compassionate, funny,
3. usual,
4. Dracula,
5. No,
6. Jordan, athletes,
7. gum, bugs, teeth,
8. brilliant, creative,
9. jazz,
10. President,

Practice (p. 195)

1. C
2. I
3. I
4. C
5. C
6. I
7. C
8. I
9. C
10. I

Practice (p. 196)

1. equipment;
2. meeting;
3. issues:
4. life:
5. easy;
6. find;
7. members:
8. discovered:
9. message;

10. words:

Practice (p. 197)

Answers will vary.

Practice (p. 199)

Words that should be circled are:
their, quiet, alot, enviroment, Your,
Wensday, Febuary, whose, you're,
knowlege, necessary, To, There, to,
truely

Dear Fred,

You know there have been quite a lot of problems with our environment recently. You're invited to a party on Wednesday the 5th of February to raise money to help the biologist clean up Lake Bradford. Nobody knows who's causing the pollution there, but your knowledge is necessary to help us stop it. Too many people are avoiding this issue. They're getting away with too much.

Yours truly,
Holly

Practice (p. 202)

Correct answers will be determined by the teacher.

Practice (p. 203)

Correct answers will be determined by the teacher.

Practice (pp. 205-206)

Correct answers will be determined by the teacher.

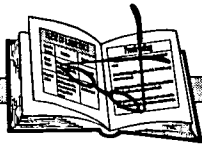

Keys

Application (p. 207)

Correct answers will be determined by the teacher.

Unit Assessment (TG: pp. 30-32)

1. sleeps
2. play
3. Have
4. doesn't
5. were
6. dreams
7. are
8. Does
9. read
10. chew
11. knives
12. four
13. children
14. boxes
15. skills
16. 1950s
17. persons
18. tornadoes
19. tooth
20. ox
21. leaf
22. ABC
23. sheep
24. mouse
25. fox
26. wig
27. Correct answers will be determined by the teacher.
28. Correct answers will be determined by the teacher.
29. Correct answers will be determined by the teacher.
30. Correct answers will be determined by the teacher.
31. Correct answers will be determined by the teacher.
32. Correct answers will be determined by the teacher.

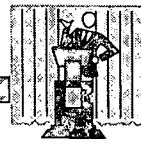

Unit 4: Listening, Viewing, Speaking— Communicating Face-to-Face

Overview

We connect with others through *communication*—the act of sending and receiving messages. You can probably think of hundreds of messages that you send and receive every day. Sometimes we send messages by using our bodies. We smile to welcome someone, or we stand at a bus stop to “tell” the driver of the next bus we would like a ride. Look me in the eye and nod your head when I speak, and I will see your interest in what I am saying. When we send or receive messages through gestures, facial expressions, or otherwise using our bodies, we are using *body language*. Body language is also called *nonverbal communication*, a way of sending messages without the use of words.

When we use words to send messages, we are using *verbal communication*. When you read a story, listen to music or a radio commercial, or write a note, you are using verbal communication. Whether your audience is one person or 40 people, you communicate well when your audience understands your message in the way you want them to. Similarly, you want to understand the messages people send to you. You also want to understand how communication can be used as a tool of persuasion. This includes knowing the ways that a sender can attempt to influence your thinking on subjects from buying a product to choosing your next president.

One of the most important acts of communication in any culture is storytelling. Storytelling is the art of telling a story to a particular audience in an interesting way. If you think back to some of the stories you have heard, you will probably agree that some stories were better than others. You may have found some stories more interesting because the subjects of the story appealed to you. Similarly, some stories kept your attention because they illustrated an interesting story or lesson. However, even an interesting story or lesson will not capture the audience’s attention if it is not told in an interesting way. A good storyteller uses storytelling techniques to gain and maintain the audience’s attention.

Our culture also uses the art of storytelling in another way: to sell products. Most of the commercials you hear on radio, see on television, or even see on billboards are brief stories intended to persuade you to buy a



product or to think in a particular way. Being able to analyze the persuasion techniques in these advertisements will help you to make wise choices. You want to use communication rather than be used by communication!

This unit leads you through the process of becoming a good storyteller. This process begins with selecting a good storytelling story, continues with practice on using visual aids effectively, and ends with using effective techniques to tell a good story. This unit also leads you through the process of becoming a good listener or watcher. A good listener and watcher knows how to analyze what he or she is hearing and seeing. A good listener also knows how to listen with interest during a class discussion, or even during a casual discussion with just a few friends.

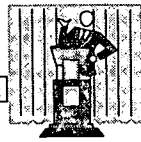

The chart below lists the *Sunshine State Standards: Language Arts* and corresponding benchmarks addressed in this unit.

Curriculum Framework: Standards and Benchmarks

- **Use reading strategies effectively to construct meaning from a range of technical, informative, and literary texts.**
 - LA.A.1.4.3 Refine vocabulary for interpersonal, academic, and workplace situations, including figurative, idiomatic, and technical meanings.
 - LA.A.2.4.5 Identify devices of persuasion and methods of appeal and their effectiveness.
 - LA.A.2.4.7 Analyze the validity and reliability of primary source information and use the information appropriately.
- **Select and use appropriate speaking, listening, and viewing skills to clarify and interpret meaning in both formal and informal situations.**
 - LA.C.1.4.1 Select and use appropriate listening strategies according to the intended purpose, such as solving problems, interpreting and evaluating the techniques and intent of a presentation, and take action in career-related situations.
 - LA.C.1.4.2 Describe, evaluate, and expand personal preferences in listening to fiction, drama, literary nonfiction, and informational presentations.
 - LA.C.1.4.3 Use effective strategies for informal and formal discussions including listening actively and reflectively, connecting to and building on the ideas of a previous speaker, and respecting the viewpoints of others.
 - LA.C.1.4.4 Identify bias, prejudice, or propaganda in oral messages.
 - LA.C.2.4.1 Determine main concept and supporting details in order to analyze and evaluate nonprint media messages.
 - LA.C.2.4.2 Understand factors that influence the effectiveness of nonverbal cues used in nonprint media, such as the viewer's past experiences and preferences, and the context in which the cues are presented.
 - LA.C.3.4.1 Use volume, stress, pacing, enunciation, eye contact, and gestures that meet the needs of the audience and topic.
 - LA.C.3.4.2 Select and use a variety of speaking strategies to clarify meaning and to reflect understanding, interpretation, application, and evaluation of content, processes, or experiences (including asking relevant questions when necessary, making appropriate and meaningful comments, and making insightful observations).
 - LA.C.3.4.3 Use details, illustrations, analogies, and visual aids to make oral presentations that inform, persuade, or entertain.
 - LA.C.3.4.4 Apply oral communication skills to interviews, group presentations, formal presentations, and impromptu situations.
 - LA.C.3.4.5 Develop and sustain a line of argument and provide appropriate support.
- **Demonstrate understanding and use of appropriate language for effective visual, oral, and written communication.**
 - LA.D.1.4.1 Apply an understanding that language and literature are primary means by which culture is transmitted.
 - LA.D.1.4.2 Make appropriate adjustments in language use for social, academic, and life situations, demonstrating sensitivity to gender and cultural bias.
 - LA.D.2.4.1 Understand specific ways in which language has shaped the reactions, perceptions, and beliefs of the local, national, and global communities.
 - LA.D.2.4.2 Understand the subtleties of literary devices and techniques in the comprehension and creation of communication.
- **Demonstrate understanding of the impact of mass media and the regulations that govern its use.**
 - LA.D.2.4.5 Critically analyze specific elements of mass media with regard to the extent to which they enhance or manipulate information.
 - LA.D.2.4.6 Understand that laws control the delivery and use of media to protect the rights of authors and the rights of media owners.



Suggestions for Teaching

1. Ask students to analyze their own attitudes and behavior towards speaking in public. Becoming self-aware through your own observations is easier and often more constructive than receiving external criticism. Ask them to analyze conversations within their family, culture, and peer group. Ask them to be aware of how they respond to someone of the opposite sex or from a different culture.
2. Once you have observed the class dynamics, assign clear roles for students during discussions: facilitator, questioner, summarizer, role-taker, etc. Assign and rotate these roles as appropriate to bring out each student's strengths and to overcome the student's weaknesses.
3. Use a ball of yarn during an informal discussion. Let the yarn unravel from speaker to speaker until a visual speech web is formed which can then be analyzed.
4. Vary the format for discussions.
 - a. Use small groups which can then make presentations to the class.
 - b. Ask each small group to discuss a unique aspect of the topic. Rotate the small groups so that each new group has one member from each original group. Each group member will then represent a specific aspect of the general topic.
 - c. Form an inner and outer circle. Ask the outer circle to listen to the inner one and then switch places.
 - d. Form an inner and outer circle. Ask the two circles to face each other. Hold one-on-one discussions, rotating one of the circles at the completion of each discussion.
 - e. Use one-on-one interviews followed by each person summarizing a partner's position to the class.
 - f. After students feel comfortable with one another, hold debates, forums, or mock talk shows.

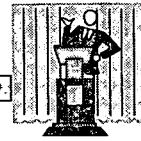

5. Have students see how many different meanings they can give to selected sentences by stressing particular words. Two examples of sentences that will convey different meanings depending on voice inflection are: "Did you go for a walk with her?" and "I don't believe you." Have competition in the class to see who can create the most variations and declare a winner.
6. Have students plan for a presentation situation by writing key words about the content, body language, and voice for each character. The students can then choose a partner and act out given situations such as the example below.

You ask to borrow money from...

- a friend.
- a bank manager.
- a stranger.
- the governor of Florida.
- a young child.

7. Use the Presentation Rubric on the following pages to help students understand key elements of storytelling. During each student's presentation assign an odd number of students (e.g., three or five) to fill in the rubric and then explain their scoring. (You may want to include yourself in each group.) If possible, you may want to show a video of a professional storyteller making a presentation and have the class use the rubric and then discuss their scores.

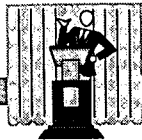

Presentation Rubric

	4	3	2	1
PREPARATION: Total points for Preparation:				
Story Knowledge	showed total knowledge of story and is prepared to answer relevant questions	showed knowledge of story but unable to answer relevant questions satisfactorily	showed incomplete knowledge of story	showed no knowledge of story beyond story text
Organization	story presented in orderly way, including introduction and visual aids	story presented in orderly way with few exceptions	story presented in entirety but some parts presented out of order	parts of story omitted or most parts presented out of order
Audience Awareness	selected story matches particular audience and presented in language appropriate to audience	selected story matches particular audience but language occasionally inappropriate for particular audience	selected story does not match particular audience or language inappropriate for particular audience	selected story does not match particular audience and language inappropriate for particular audience
Use of Rehearsal	speaker has rehearsed often and incorporated suggestions from peer and teacher critiques	speaker has rehearsed often but has incorporated only a few suggestions from peer and teacher critiques	speaker has not rehearsed often and has not incorporated suggestions from peer and teacher critiques	speaker has not rehearsed
SPEAKING: Total points for Speaking:				
Pronunciation	all words spoken clearly and distinctly	most words spoken clearly and distinctly	many words were mumbled or run together	most words were not spoken clearly
Volume	audience found volume varied to match changing contents of story	audience found volume varied to match most of the contents of story	audience found volume was neither too loud nor too soft but did not vary to match contents of story	audience found volume was either too loud or too soft
Tempo	pace helped audience hear words clearly and maintain interest	pace helped audience hear words clearly but occasionally sped up or slowed down without purpose	pace was either too fast or too slow throughout for comfort of audience	pace varied without reason and disoriented audience
Pitch	tone matched action of story throughout	tone matched action of story with few exceptions	tone was not used to move audience	tone moved audience to emotions not intended by story

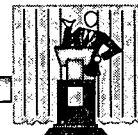

Presentation Rubric

	4	3	2	1
BODY LANGUAGE:				
			Total points for Body Language:	
Eye Contact	speaker made appropriate eye contact with listeners	speaker made eye contact with each listener but did not hold contact long enough	speaker looked in direction of audience but did not make eye contact with individual members	speaker did not look at audience (gazed at floor, ceiling, etc.)
Gestures	speaker used hands, head, and other body parts to express parts of story appropriately	speaker often used gestures appropriately but occasionally lapsed into inactivity	speaker used gestures only for the most intense part(s) of story	speaker did not gesture or used gestures inappropriately
Posture	speaker carried and held body in a straight line while standing, sitting, or walking, except to emphasize a part of story	speaker held body in a straight line but lapsed occasionally into a slouch, then regained erect posture	speaker lapsed into a slouch and did not regain erect posture	speaker slouched throughout
VISUAL AIDS:				
			Total points for Visual Aids:	
Enhanced Story	creative and original	unoriginal but vivid and well made	unoriginal and poorly made	were not used
Relative to Story	were relevant to the story and helped audience understand all parts and characters in the story	were relevant to the story	were not relevant and distracted from story	were not used
Held Audience's Attention	speaker manipulated aids flawlessly	speaker manipulated aids with few mistakes	speaker misused often in handling aids	were not used
Easy to Understand	purpose clear, size and shape helped audience perceive completely	purpose clear, size and shape slightly obscured audience's perception	purpose unclear, or size and shape obscured audience's perception	were not used



Presentation Rubric

	4	3	2	1
CULTURAL INFORMATION AND INTRODUCTION:			Total Points for Cultural Information and Introduction:	
Attention Grabber	introduction hooked audience's attention through interesting and informative content	introduction hooked audience's attention but did not include relevant information	introduction did not hook audience's attention and did not include relevant information	introduction was omitted
Background Provided	speaker thoroughly explained the function of this story in its original culture	speaker briefly explained either the function or the original culture of this story	speaker mentioned but did not explain the function or the original culture of this story	speaker omitted any mention of the function or the original culture of this story
Relates to Audience	speaker clearly established strong link between original culture of this story and the audience in a creative and original way (e.g., points out similar values, shows how story could be updated, etc.)	speaker established strong link but in typical or unoriginal way	speaker only mentioned link and did not elaborate	speaker omitted any mention of link
Presentation Total Points: _____				

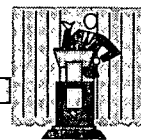

Unit Assessment

Answer the following questions with short answers.

1. What is one example of verbal communication and one example of nonverbal communication?

2. What is one important function of adults telling fables or folk tales to children?

3. Is the following statement *true* or *false*? During a formal presentation we should use expressions such as *UM*, *Ya know*, *Like um*, *ER*, and *I mean* because we use those expressions in conversations with our friends.

4. Should a storyteller speak softly or loudly when presenting a story about a sad child who has just lost his favorite pet?

Should a storyteller speak softly or loudly when presenting a story about a duel between two pirates on a ship that is tossing and turning during a tropical storm?



5. Match the story in the left-hand column with the most likely appropriate audience in the right-hand column.

Story	Audience
_____ 1. a simple story about an animal that talks	A. an elderly person
_____ 2. a story about a teenager who refuses to go along with her peer group	B. a young child
_____ 3. a complicated story about a person who finds love when he is retired	C. a high school student

6. What should a speaker do with his or her eyes during a presentation?

7. Describe the posture a speaker should use to convey confidence and readiness to an audience.

8. What is the definition of the following words?

tempo: _____

pitch: _____

enunciation: _____

volume: _____

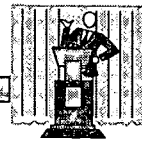

9. Circle the letter of those items that best describe what visual aids should accomplish in a presentation.
- a. enhance, not distract, from the presentation
 - b. hold the audience's attention
 - c. distract the audience from the subject of the presentation
 - d. bore the audience so they will listen more closely to what you are saying
 - e. be hard to read so the audience will have to pay closer attention
 - f. be easy to read and understand

10. Describe someone who you consider to be an effective speaker. Explain why you think he or she is an effective speaker. Be specific. This could be someone you know personally or a public figure.

11. What are three ways of using body language in a class discussion to indicate you are paying attention?

12. If you do not use active listening techniques (such as taking notes and asking follow-up questions) during a class discussion, what may happen?



13. Which of the following techniques should be used when you speak during a class discussion?
- a. Avoid eye contact.
 - b. Respond to others.
 - c. Stay on subject.
 - d. Make connections.
 - e. Interrupt if you disagree.
 - f. Think ahead.
 - g. Talk about yourself often.
 - h. Ignore other people's feelings.
14. Explain briefly why listening is as important as speaking in a class discussion.

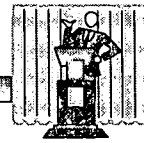

Keys

Practice (pp. 217-218)

Correct answers will be determined by the teacher.

Application (pp. 219-220)

Correct answers will be determined by the teacher.

Practice (p. 222)

Correct answers will be determined by the teacher.

Application (p. 223)

Correct answers will be determined by the teacher.

Practice (p. 227)

Correct answers will be determined by the teacher.

Practice (p. 228)

Correct answers will be determined by the teacher.

Practice (p. 229)

Correct answers will be determined by the teacher.

Application (p. 230)

Correct answers will be determined by the teacher.

Practice (pp. 234-235)

1. Appealing to Our Emotions
2. Get On the Bandwagon
3. Celebrity Testimonials
4. The Either/Or Appeal
5. Abusing Statistics and Facts

6. Hasty Generalizations
7. Glittering Language

Application (p. 236)

Correct answers will be determined by the teacher.

Application (pp. 237-238)

Correct answers will be determined by the teacher.

Application (p. 242)

Correct answers will be determined by the teacher.

Unit Assessment (TG: pp. 47-50)

1. speaking; body language
2. Answers should include the following: They teach an important cultural lesson or moral to children; they tell the tradition or history of a culture.
3. False
4. softly; loudly
5.
 1. B.
 2. C.
 3. A.
6. The speaker should look directly into the eyes of people in the audience.
7. The speaker should carry or hold her body in straight alignment at all times.
8. tempo: the speed at which words are spoken
pitch: the highness or lowness of the sound of the voice
enunciation: speaking clearly
volume: the strength or amount of sound produced by the voice
9. a; b; f
10. Correct answers will be determined by the teacher.



Keys

11. look at the speaker; nod your head; sit up and don't fidget
12. Answers may include: You may lose track of conversation and be unable to participate; you may say something irrelevant; the speaker may feel uncomfortable or nervous; the speaker may assume you understand something you don't.
13. b; c; d; f
14. Answers will vary, may include: Listening enables you to follow and digest information, which will in turn make your comments succinct and relevant. Listening encourages others to speak.



Unit 5: Literature—Discovering the World, Discovering Ourselves

Overview

Literature—writing that has lasting value—is characterized by its use of language that is elastic and powerful. Writers can stretch their words into riveting drama or squeeze them into stunning poetic images. Writers and the literature they create have the power to capture the emotions that come with being human: triumph, passion, or loneliness. When we read literature we know that we are not alone, that across history others have shared our experiences and emotions.

All literature is either *fiction* or *nonfiction* or a combination of both. In this unit you will learn about the differences between fiction and nonfiction, the different forms of literature called *genres*, and common literary elements. At the end of this unit you will select a piece of literature, analyze it, and decide whether or not you would recommend it to other students. Your work throughout this unit will provide you with the tools and knowledge to help you complete this task.

Literature can open a whole universe of possibilities to a critical reader. It can take you to exotic places, introduce you to famous people, or teach you about yourself. Once you have unlocked the key to understanding literature, the world is just an open book away!



The chart below lists the *Sunshine State Standards: Language Arts* and corresponding benchmarks addressed in this unit.

Curriculum Framework: Standards and Benchmarks

- **Use reading strategies effectively to construct meaning from a range of technical, informative, and literary texts.**
 - LA.A.1.4.1 Select and use prereading strategies that are appropriate to the text, such as discussion, making predictions, brainstorming, generating questions, and previewing to anticipate content, purpose, and organization of a reading selection.
 - LA.A.2.4.2 Determine the author's purpose and point of view and their effects on the text.
- **Demonstrate understanding and use of appropriate language for effective visual, oral, and written communication.**
 - LA.D.1.4.1 Apply an understanding that language and literature are primary means by which culture is transmitted.
 - LA.D.2.4.2 Understand the subtleties of literary devices and techniques in the comprehension and creation of communication.
- **Demonstrate understanding of the impact of mass media and the regulations that govern its use.**
 - LA.C.1.4.2 Describe, evaluate, and expand personal preferences in listening to fiction, drama, literary nonfiction, and informational presentations.
- **Understand the common features of a variety of literary forms.**
 - LA.E.1.4.1 Identify the characteristics that distinguish literary forms.
 - LA.E.1.4.3 Identify universal themes prevalent in the literature of all cultures.
 - LA.E.1.4.4 Understand the characteristic of major types of drama.
 - LA.E.1.4.5 Understand the different stylistic, thematic, and technical qualities present in the literature of different cultures and historical periods.
 - LA.E.2.4.1 Analyze the effectiveness of complex elements of plot, such as setting, major events, problems, conflicts, and resolutions.
 - LA.E.2.4.2 Understand the relationships between and among elements of literature, including characters, plot, setting, tone, point of view, and theme.
 - LA.E.2.4.3 Analyze poetry for the ways in which poets inspire the reader to share emotions, such as the use of imagery, personification, and figures of speech, including simile and metaphor; and the use of sound, such as rhyme, rhythm, repetition, and alliteration.
 - LA.E.2.4.6 Recognize and explain those elements in texts that prompt a personal response, such as connections between one's own life and the characters, events, motives, and causes of conflict in texts.
- **Respond critically and aesthetically to literature.**
 - LA.A.2.4.3 Describe and evaluate personal preferences regarding fiction and nonfiction.



Suggestions for Teaching

Nonfiction

“I Have a Dream” by Martin Luther King, Jr.

In 1963 Martin Luther King, Jr., addressed this speech to a huge crowd in Washington, D.C. It is about his dream that one day all Americans will be treated equally. The speech is persuasive and appeals to the spirit of freedom in the Bible and the Declaration of Independence.

Possible purposes of this selection include the following:

1. to provide a thematic parallel to the poems in this unit
2. to expand students’ views on contemporary issues such as equality and oppression
3. to explore personal dreams

Suggested Activities for This Selection

1. Martin Luther King, Jr., wrote this speech in 1963. Ask students to discuss and write about how many of his dreams have come true thirty years later. Identify those which have not and write about why.
2. Ask students to compare and contrast this speech with Maya Angelou’s 1993 inaugural poem, “On the Pulse of Morning.”
3. Ask students to examine the issue of freedom in their own lives.
4. Ask students to describe their own dreams.
5. Ask students to identify Martin Luther King’s literary inspirations for this speech.
6. Ask students to read “Harrison Bergeron” by Kurt Vonnegut, Jr., as a follow-up or lead-in to *Flowers for Algernon*. It is a story based on the idea that the only way to achieve true equality would be to disable everyone’s exceptional qualities and reduce all people to a low common denominator.



Short Stories

"The Most Dangerous Game" by Richard Connell

In this story a renowned hunter, Rainsford, is stranded on an island. While on the island, a mysterious man, General Zaroff, forces Rainsford to participate in a hunt in which Rainsford is the prey. This suspenseful plot investigates the theme of role reversal: A hunter begins to empathize with the hunted.

Possible purposes of this selection include the following:

1. to understand plot, conflict, climax, and resolution in a short story with an emphasis on external conflict
2. to reinforce the use of chronological order
3. to examine role reversal as an aid to understanding and a technique for persuasion
4. to supplement discussion of ethical issues in *Flowers for Algernon*
5. to illustrate third-person narrative

Suggested Activities for This Selection

1. Ask students to write a plot outline emphasizing the story's chronological order.
2. Ask students to discuss and write about the general's statement: "Life is for the strong." Use as an exploration of students' positions in the school and others' attitudes towards them.
3. Ask students to discuss and write about how Rainsford feels as the hunted instead of the hunter.
4. Ask students to brainstorm and write about other role reversal situations such as majority becomes minority and vice versa; parent becomes child and vice versa; African American becomes white and vice versa; female becomes male and vice versa (this last one could be used in conjunction with reading *Taming of the Shrew*).



“Louisa, Please Come Home” by Shirley Jackson

In this story a troubled teenaged girl, Louisa, runs away from home on the day of her sister’s wedding. She creates a new life and personality for herself in a nearby town. Every year on the radio, Louisa’s family appeals to her to come home. She is finally recognized by a neighbor, who takes her home in order to receive a reward. However, the family has been victimized by many girls claiming to be their daughter. When their real Louisa returns, they believe she too is an imposter.

Possible purposes for this selection include the following:

1. to understand plot conflict, climax, and resolution in a short story with an emphasis on internal conflict
2. to explore the theme of being an “outsider”

Suggested Activities for This Selection

1. Ask students to write a plot outline emphasizing the story’s chronological order.
2. Ask students to compare and contrast Rainsford’s conflict (in “The Most Dangerous Game”) with Louisa’s.
3. Ask students to discuss and research family issues and teenage runaways. Have students prepare and deliver an oral report in which students give information about sources of support, hotlines, etc. Or have a class discussion on these same issues.
4. Ask students to write a letter of advice to Louisa and to her family suggesting better ways of resolving conflicts such as theirs.

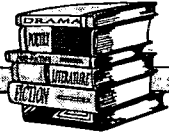

“The Cask of Amontillado” by Edgar Allen Poe

The main character of this short story, Montresor, believes himself to have been insulted by one Fortunato. By flattery he lures the unfortunate Fortunato into his family crypt. Once inside, Montresor proceeds to revenge himself by enchaining and entombing Fortunato alive. The setting of the story, in the dark, dank catacombs, contributes greatly to the atmosphere and suspense.

Possible purposes for this selection include the following:

1. to examine setting in a short story
2. to analyze suspense in a short story
3. to illustrate the use of first-person narrative
4. to understand how emotions are used in a short story
5. to explore the use of sensory detail in fiction writing

Suggested Activities for This Selection

1. Ask students to describe the setting of this story.
2. Ask students to explain how the setting creates suspense in this story, and brainstorm other suspenseful settings for horror stories.
3. Ask students to identify sensory details for each sense from the story. Ask students to supply sensory details for each sense for one of the settings they brainstorm in the previous activity.
4. Ask students to use first-person narrative to narrate the story from Fortunato’s point of view.

Suggested Activities for Comparing Fundamental Characteristics of the Short Story and Novel Selections

1. Ask students to list essential information they know about Rainsford, Louisa, and Montresor. Compare this to what they know about Charlie in *Flowers for Algernon*. Discuss how this relates to the different characteristics of each genre. As a follow-up, students could supply imagined biographies about one of the short story characters. Students should note that the novel allows a more in-depth profile of Charlie.



2. Ask students to identify the climaxes and resolutions of the novel and short stories. Discuss different answers and alternative resolutions.
3. Ask students to identify emotions experienced by Charlie and compare these to those experienced by Rainsford, Louisa, and Montresor. Discuss how these findings reflect the different characteristics of each genre. Students should note that the short stories are primarily dominated by one emotion, whereas the emotions presented in the novel are more complex.
4. Ask students to write themselves into the plot outline of the novel or one of the short stories. Ask them to describe how their presence would alter the plot and explain why they chose to intervene in that particular story.
5. Ask students to identify the protagonist and antagonist for each story.
6. Ask students to identify the central emotions experienced by Rainsford ("The Most Dangerous Game"), Louisa ("Louisa, Please Come Home"), and/or Fortunato ("The Cask of Amontillado").

Novels

Flowers for Algernon by Daniel Keyes

A kind, mentally disabled man called Charlie becomes the subject of an experiment designed to considerably magnify his intellectual abilities. During the experiment he becomes very attached to a lab mouse called Algernon. As his I.Q. increases, Charlie begins to perceive the hypocrisy and cruelty of the experiment and the scientists. The effects of the surgery do not last and Charlie's I.Q. gradually diminishes, leaving the reader questioning the morality of scientific experimentation and the idea that ignorance is indeed bliss.

Possible purposes of this selection include the following:

1. to allow students to explore the themes of intelligence, character, and self-worth with which they are often confronted as learners with diverse needs

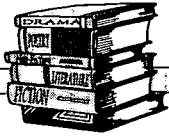

2. to examine characterization in a novel
3. to explore journal writing

Suggested Activities for This Selection

1. Ask students to debate and/or write about the ethics of the operation.
2. Ask students to consider whether or not they would undergo such an operation if the outcome could be guaranteed and if it could not. Use this to discuss their feelings towards being an exceptional student and the attitudes of others towards them.
3. Ask students to identify and explore conflict in the novel.
4. Ask students to keep an imaginary journal by either Miss Kinnian, Professor Nemur, or Dr. Strauss.
5. Ask students to research and report on animal experimentation.
6. Ask students to read "Harrison Bergeron" by Kurt Vonnegut, Jr., a follow-up to this novel (see also "Nonfiction").

Poetry

"The Negro Speaks of Rivers" and "Justice" by Langston Hughes

Possible purposes for these selections include the following:

1. to illustrate how poetry can condense powerful human issues into imagery and metaphor
2. to introduce free verse and rhyming verse

"l1" and "92" by E. E. Cummings

Possible purpose for these selections include the following:

1. to illustrate the freedom and flexibility poets have with the structure and form of language

"Knoxville, Tennessee," "Kidnap Poem," and "The Funeral of Martin Luther King, Jr." by Nikki Giovanni



Possible purpose for these selections include the following:

1. to illustrate how personal experience can translate into poetry

Suggested Activities for These Selections

1. Use the poems "The Funeral of Martin Luther King, Jr.," "II," and "Justice" to supplement the nonfiction selection "I Have a Dream." Ask students to discuss and compare the merits of these two genres when they address a similar topic.
2. Ask students to compare E. E. Cummings' "92" to Nikki Giovanni's "Kidnap Poem" by identifying metaphors in both poems. Then ask students to write a love poem of their own. If this is too difficult, you or the class could come up with an extended metaphor for love and let students write a line each for a class poem. For example, use the metaphor of a fairground to write about love.
4. Ask students to write a poem in the form of a list of sensory details similar to Nikki Giovanni's "Knoxville, Tennessee." Ask them to capture in their poem a time, person, or place that has meant a lot to them. This is an easy poetic form to master for students who are nervous about their ability to write poetry.
5. Discuss how line breaks can be used in poetry. Discuss how the flexible form of poetry, including line breaks, is one of the fundamental characteristics of this genre. To illustrate this, ask students to rewrite one of E. E. Cummings' poems using correct mechanics or give them a simple sentence to rewrite into poetry, allowing them only to use line breaks, punctuation, and form as a tool. (They cannot add, subtract, or rearrange the order of the words.)



For example:

I need to find you soon, I'm lonely.

could become:

I

NEED

to find

YOU

Soon

I'm

lonely...

Drama

Romeo and Juliet by William Shakespeare

Romeo and Juliet is a romantic tragedy in which a pair of young "star-crossed lovers" try to overcome the mutual prejudice between their two families. Romeo kills Juliet's cousin and must flee from her and her family. Though they manage to marry in secret, a series of fatal misunderstandings, one of which involves Juliet faking her demise, results in Romeo's suicide. Upon waking from her drug-induced "death," Juliet discovers Romeo's body and, heartbroken, kills herself. Their two families, the Montagues and Capulets, are then forced to confront the consequences of their rivalry and make peace.

Taming of the Shrew by William Shakespeare

Taming of the Shrew is a romantic comedy in which male-female relationships are closely scrutinized. Bianca is forbidden to marry until a husband can be found for her jealous and conniving older sister, Kate. No man is willing to contend with Kate until Petruchio appears, seeking a hefty dowry rather than romantic love. Kate is married off to Petruchio,



leaving Bianca's many suitors free to compete for her love. Petruchio attempts to *tame* his bride by "killing her with kindness." Eventually, Kate complies with Petruchio's demands, though her motive is somewhat unclear. At Bianca's wedding, Kate is the very model of a subservient wife, winning Petruchio a large sum of money from a bet the men have over whose wife is the most obedient.

Possible purposes for these selections include the following:

1. to analyze characterization in drama
2. to explore the themes of love and romance
3. to understand protagonist and antagonist
4. to examine conflict, climax, and resolution
5. to define comedy and tragedy

Suggested Activities for These Selections

1. Ask students to identify round and flat characters in each play. Ask students to rewrite and even act a scene in which the plot is revealed from a flat character's point of view.
2. Ask students to contrast characterization in drama with characterization in a novel. Draw out ways in which drama relies on external portrayals of inner emotion, as well as the effects of costume, lighting, and movement on characterization. Ask students to select a main character from one of the plays and to write a letter describing how they would direct an actor portraying that character. In the letter they should particularly consider motivation, costuming, and relationships with other characters. A good character to do this activity about is Kate in *Taming of the Shrew* since there is much room for interpretation about how and why she resolves her conflict with Petruchio.
3. Ask students to identify protagonists and antagonists in *Romeo and Juliet*. Since young people have a lot of interest in the issue of love and obstacles to it, there are many good ways to further examine this topic. Some possibilities include the following:

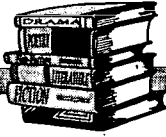

- a. rewriting the plot into a contemporary setting
 - b. discussions comparing love for young people today with that of Romeo and Juliet's time
 - c. putting the antagonists on trial in a mock courtroom
 - d. establishing teen-to-teen advice columns within the class or school
4. Once students have identified protagonists and antagonists in *Romeo and Juliet*, hold a debate about who is the protagonist and who is the antagonist in *Taming of the Shrew*. It is more effective if students have to prepare a case for Kate as the antagonist, Petruchio as the protagonist, and vice versa. Announce the teams for the debate only on the day it occurs. This should introduce the idea that drama cannot always be neatly defined.
 5. Ask students to identify the climax and resolution in *Romeo and Juliet*. After this, ask them to rewrite the ending in order to prevent the play from being a tragedy.
 6. Again, *Taming of the Shrew* provides students with an opportunity to explore climax and resolution beyond the typical definitions. Discuss the climax of this play and Kate's speech to the other wives at its conclusion. If possible, show videos of different portrayals of Kate to illustrate that the climax and resolution are subject to interpretation both by the actors and the director. Ask students to do one of the following:
 - a. Imagine Kate keeps a journal after her marriage in which she reveals her true attitude toward Petruchio. Write entries from the journal.
 - b. Ask students to write an imaginary scene following the final act. Ask them to clarify the resolution or write one in their final scene.
 7. Ask students to define comedy and tragedy by contrasting the two plays.



Autobiography and Biography

Night by Elie Wiesel

This account of a young boy's experiences in Auschwitz and Buchenwald concentration camps leaves the reader shocked and deeply moved. Elie Wiesel loses his family to the Nazis and in the process also loses his innocence and his faith. Although the autobiography ends with the liberation of the camp, Wiesel indelibly impresses upon the reader that no human should ever again witness what he has witnessed.

Possible purposes of this selection include the following:

1. to understand how autobiography can allow readers to powerfully experience history first-hand through the eyes of an *ordinary* person
2. to put the contemporary teenage experience into a wider perspective (the protagonist in *Night* is a teenager)
3. to compare and contrast the personal experiences of students with that of Elie Wiesel
4. to compare and contrast autobiography and biography

Suggested Activities for This Selection

1. Ask students to trace and describe the changes that take place in Elie Wiesel over the course of the autobiography and identify the sources of those changes.
2. Ask students to compare a brief biography of Hitler with *Night* and to analyze the merits of examining history from each of these perspectives.
3. Ask students to explore in autobiographical writing their own experiences of loss of innocence, crisis of faith, or loss of family. They could deliver a speech on this subject if it is not too private.
4. Ask students to research one of the following topics in order to participate in a class discussion or present an informative oral report:
 - a. the causes of the rise of neo-Nazism among teenagers

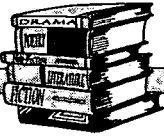

- b. sources of support for people suffering from the loss of a loved one
 - c. sources of support for teenagers in crisis
 - d. the fight for freedom of religion
 - e. the effects of war on young people
 - f. ways in which young people can help prevent Elie Wiesel's experiences from ever happening again
5. Follow-up reading may include other biographies of Elie Wiesel, *The Diary of Anne Frank*, or *Born on the 4th of July*.
 6. Ask students to compare and contrast a brief biography of Elie Wiesel with his autobiography, *Night*. Discuss how he resolved or continues to address his experiences in *Night* in his work today.



Unit Assessment

Characteristics of Literature

Answer the following questions.

1. What are two specific differences between fiction and nonfiction?

2. What are three common literary elements which may be found in poetry?

3. What are four fundamental characteristics that novels, plays, and short stories have in common?



4. What are the differences between a short story and a novel?

5. What are the fundamental characteristics of drama that are *not* found in novels or short stories?

6. Compare and contrast *biography* and *autobiography*.

7. Give one example of each genre below.

poetry: _____

short story: _____

drama: _____

novel: _____

nonfiction: _____

biography: _____

autobiography: _____



8. Which genre or genres do you most enjoy reading? _____

Why? _____

9. Which genre or genres do you most enjoy writing? _____

Why? _____

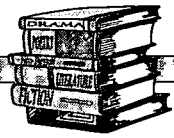

Keys

Practice (p. 253)

1. N
2. F
3. N
4. F
5. F
6. N
7. N
8. N
9. N
10. N
11. N
12. F
13. N
14. F
15. N

Practice (p. 254)

1. Correct answers will be determined by the teacher.
2. Correct answers will be determined by the teacher.
3. nonfiction; The article is based on factual information and real-life events.

Practice (p. 257)

Correct answers will be determined by the teacher.

Practice (p. 258)

Correct answers will be determined by the teacher.

Application (pp. 259-260)

Correct answers will be determined by the teacher.

Practice (p. 266)

1. B.
 2. A.
 3. D.
 4. E.
 5. C.
-
1. E.
 2. B.
 3. D.
 4. A.
 5. C.

Practice (p. 270)

Correct answers will be determined by the teacher.

Application (p. 271)

Correct answers will be determined by the teacher.

Application (pp. 272-273)

Correct answers will be determined by the teacher.

Practice (pp. 276-277)

Correct answers will be determined by the teacher.

Practice (p. 280)

1. novel
2. short story
3. both
4. short story
5. novel
6. novel
7. novel
8. both
9. both
10. short story

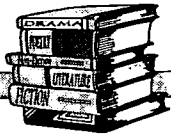

Keys

Practice (pp. 281-284)

Correct answers will be determined by the teacher.

Practice (pp. 285-286)

Correct answers will be determined by the teacher.

Application (p. 287)

Correct answers will be determined by the teacher.

Practice (pp. 293-299)

1. Correct answers will be determined by the teacher.
2. Correct answers will be determined by the teacher.
3. He uses only lower case and no punctuation; to force readers to see the words in a new way and read with a fresh eye.
4. Correct answers will be determined by the teacher.
5. Correct answers will be determined by the teacher.
6. Correct answers will be determined by the teacher.
7. Correct answers will be determined by the teacher.
8. Correct answers will be determined by the teacher.
9. Correct answers will be determined by the teacher.
10. Correct answers will be determined by the teacher.
11. Correct answers will be determined by the teacher.

Practice (pp. 302-303)

Correct answers will be determined by the teacher.

Practice (pp. 304-305)

Correct answers will be determined by the teacher.

Practice (pp. 307-308)

Correct answers will be determined by the teacher.

Application (p. 309)

Correct answers will be determined by the teacher.

Practice (pp. 311-312)

Correct answers will be determined by the teacher.

Application (p. 313)

Correct answers will be determined by the teacher.

Practice (p. 316)

Answers are given below. Teacher will determine if they are placed correctly on the web.

told by the subject of the book

uses *I* to refer to himself in the story

nonfiction

true stories about a person's life

told by a person other than the subject of the book

uses *he*, *she*, or *it* to refer to the subject of the story

nonfiction

true stories about a person's life



Keys

Application (pp. 317-318)

Correct answers will be determined by the teacher.

Practice (p. 321)

Correct answers will be determined by the teacher.

Application (p. 322)

Correct answers will be determined by the teacher.

Unit Assessment (TG: pp. 67-69)

1. Fiction is writing based on imagination, whereas nonfiction is writing based on real people or events. The main purpose of fiction is to entertain, whereas the main purpose of nonfiction is to inform, educate, or persuade using factual information.
2. Answers should include three of the following: metaphor, personification, simile, rhyme, and rhythm.
3. Answers should include four of the following: plot, conflict, theme, setting, suspense, protagonist, antagonist, and climax.
4. A short story will generally have one major conflict, center around one plot, develop one major character in a limited way, contain one theme, and use limited settings, whereas a novel will generally have more than one conflict, center around one major plot but with several subplots, fully develop more than one character, contain more than one theme, and use many fully developed settings.
5. Fundamental characteristics of

drama that are not found in novels or short stories include the following: divided into acts; intended (generally) to be performed on stage by actors in costumes with props and music; includes stage directions.

6. Biographies and autobiographies are nonfiction accounts of a person's life. An autobiography is told by the subject of the work and is written in first person. A biography is told by someone other than the subject of the work and is written in third person.
7. Correct answers will be determined by the teacher.
8. Correct answers will be determined by the teacher.
9. Correct answers will be determined by the teacher.



Unit 6: Integrating Online Technology—Using the Information Highway

Overview

At one time it was the telephone. Then it was the television. When these technological gadgets first hit the market, most people thought they would never become household items. They were just a passing fancy. Nothing could have been further from the truth. The telephone and television have become so common that indeed we are surprised when we don't find both of them in someone's home. In fact, we may be surprised if we don't find two telephones and televisions in someone's home.

So it was with the computer during its infancy in the 1960s. Few people had the foresight to imagine that computers would become a common and necessary part of our everyday lives. Try to imagine all computers being gone, starting with personal computers to the incredibly powerful computers that run our country's telephone systems. Imagine how our lives would change in a flash!

Computers and online technology have given us access to a wealth of materials, including articles, texts, and other documents. In the past, your research for a school project would have been limited to the contents of your local libraries. You could have gotten documents from distant libraries, but the process would have taken weeks, at least. Today you can get many research articles and books in the time it takes to get on the Internet, locate the document, download, or view it. Often, the process can be done in a matter of minutes. In this unit you will learn how to find documents you want on the Internet.

Computers and online technology have also helped us create a new mail system. In a matter of seconds you can send a message on the Internet to any other computer system that is online. You can be anywhere and read the mail, even on vacation or at the beach. Sending a letter from Florida to California over the Internet takes seconds, just a few strokes of the keys and a few clicks of a mouse, as you will learn in this unit.

Like all technology, computers and online technology can be used for good and productive purposes or can be used to waste time. The knowledge you gain in this unit will help you operate on the information highway. What you do once you're on the Internet is up to you. Use it wisely and responsibly.



The chart below lists the *Sunshine State Standards: Language Arts* and corresponding benchmarks addressed in this unit.

Curriculum Framework: Standards and Benchmarks

- Use reading strategies effectively to construct meaning from a range of technical, informative, and literacy texts.

- LA.A.1.4.3 Refine vocabulary for interpersonal, academic, and workplace situation, including figurative, idiomatic, and technical meaning.
- LA.A.2.4.4 Locate, gather, analyze, and evaluate written information for a variety of purposes, including research projects, real-world task, and self-improvement.
- LA.A.2.4.6 Select and use appropriate study and research skills and tools according to the type of information being gathered or organized, including almanacs, government publications, microfiche, news sources, and information services.
- LA.A.2.4.7 Analyze the validity and reliability of primary source information and use the information appropriately.
- LA.A.2.4.8 Synthesize information from multiple sources to draw conclusions.

- Use process writing strategies effectively to meet the needs of a variety of audiences, writers, and types of information being communicated.

- LA.B.1.4.1 Select and use appropriate prewriting strategies, such as brainstorming, graphic organizers, and outlining.
- LA.B.1.4.2 Draft and revise writing that
 - is focused, purposeful, and reflects insight into the writing situation;
 - has an organizational pattern that provides for a logical progression of ideas;
 - has effective use of transitional devices that contribute to a sense of completeness;
 - has support that is substantial, specific, relevant, and concrete;
 - demonstrates a commitment to and involvement with the subject;
 - uses creative writing strategies as appropriate to the purpose of the paper;
 - demonstrates a mature command of language with precision of expression;
 - has varied sentence structure; and
 - has few, if any, convention errors in mechanics, usage, punctuation, and spelling.
- LA.B.1.4.3 Produce final documents that have been edited for
 - correct spelling;
 - correct punctuation, including commas, colons, and common use of semicolons;
 - correct capitalization;
 - correct sentence formation;
 - correct instances of possessives, subject/verb agreement, instances of noun/pronoun agreement, and the intentional use of fragments for effect; and
 - correct formatting that appeals to readers, including appropriate use of a variety of graphics, tables, charts, and illustrations in both standard and innovative forms.
- LA.B.2.4.2 Organize information using appropriate systems.
- LA.B.2.4.3 Write fluently for a variety of occasions, audiences, and purposes, making appropriate choices regarding style, tone, level of detail, and organization.



Continued

Curriculum Framework: Standards and Benchmarks

- **Demonstrate understanding and use of appropriate language for effective visual, oral, and written communication**

- L.A.D.1.4.2 Make appropriate adjustments in language use for social, academic, and life situations, demonstrating sensitivity to gender and cultural bias.

- L.A.D.2.4.1 Understand specific ways in which language has shaped the reactions, perceptions, and beliefs of the local, national, and global communities

- **Select and use a variety of electronic media to create, revise, retrieve, and verify information.**

- L.A.B.2.4.1 Write text, notes, outlines, comments, and observations that demonstrate comprehension and synthesis of content, processes, and experiences from a variety of media.

- L.A.B.2.4.2 Organize information using appropriate systems.

- L.A.B.2.4.4 Select and use a variety of electronic media, such as the Internet, information services, and desktop-publishing software programs, to create, revise, retrieve, and verify information.

- **Demonstrate understanding of the impact of mass media and the regulations that govern its use.**

- L.A.D.2.4.5 Critically analyze specific elements of mass media with regard to the extent to which they enhance or manipulate information.

- L.A.D.2.4.6 Understand that laws control the delivery and use of media to protect the rights of authors and the rights of media owners.



Suggestions for Teaching

1. Have students find a “Real Time Chat or Live Interview” with a current author.
2. Have students find a site that allows them to ask questions of an expert in a specific field or respond to a survey or question.
3. Have students use the Internet to gather data to be used in a debate or presentation.
4. Encourage students to use e-mail as a way to study correct grammar or improve their writing skills. Have students write to a mentor or maintain a daily journal.
5. Create a web site and publish students’ poems, short stories, etc.



Unit Assessment

Get on the Internet using a browser and research a topic of your choice or one assigned by your teacher. Write a short paragraph below about your topic. Use MLA style to cite the electronic references.



Keys

Practice (p. 334)

Correct answers will be determined by the teacher.

Practice (p. 339)

Correct answers will be determined by the teacher.

Practice (p. 343)

Correct answers will be determined by the teacher.

Practice (p. 344)

Correct answers will be determined by the teacher.

Application (p. 345)

Correct answers will be determined by the teacher.

Unit Assessment (TG: p. 79)

Correct answers will be determined by the teacher.

Appendices

Accommodations/Modifications for Inclusion

The following accommodations/modifications may be necessary for students with exceptionalities and diverse learning needs to be successful in inclusion classes. The specific strategies may be incorporated into the Individual Educational Plan (IEP).

Environmental Strategies

- Provide preferential seating. Seat student near someone who will be helpful and understanding.
- Assign a peer tutor to review information or re-explain.
- Build rapport with student; schedule regular times to talk.
- Reduce classroom distractions.
- Increase distance between desks.
- Note that student may need frequent breaks for relaxation and small talk.
- Accept and treat the student as a regular member of the class. Do not point out that the student is an ESE student.
- Note that student may leave class to attend the ESE support lab.
- Additional accommodations may be needed.

Organizational Strategies

- Help student use an assignment sheet/notebook or monthly calendar.
- Allow student additional time to complete tasks/take tests.
- Help student organize notebook or folder.
- Help student set timelines for completion of long assignments.
- Help student set time limits for assignment completion. Question student to help focus on important information.
- Help highlight the main concepts in the book.
- Ask student to repeat directions given.
- Ask parents to structure study time. Give parents information about long-term assignments.
- Provide information to ESE teachers/parents concerning assignments, due dates, and test dates.
- Allow student to have an extra set of books at home and in the ESE classroom.
- Additional accommodations may be needed.

Motivational Strategies

- Encourage student to ask for assistance when needed.
- Be aware of possible frustrating situations.
- Reinforce appropriate participation in your class.
- Use nonverbal communication to reinforce appropriate behavior.
- Ignore nondisruptive, inappropriate behavior as much as possible.
- Allow provisions for physical movement (distributing materials, running errands, etc.).
- Develop and maintain a regular school/home communication system.
- Encourage development and sharing of special interests.
- Capitalize on student's strengths.
- Provide opportunities for success in a supportive atmosphere.
- Assign student to leadership roles in class or assignments.
- Assign student a peer tutor/support person.
- Assign student an adult volunteer or mentor.
- Additional accommodations may be needed.

Presentation Strategies

- Tell student the purpose of the lesson and what will be expected during the lesson (provide advance organizers).
- Communicate orally and visually, and repeat as needed.
- Provide copies of teacher's notes or student's notes (preferably before class starts).
- Accept concrete answers; provide abstractions that student can handle.
- Stress auditory/visual/kinesthetic mode of presentation.
- Recap or summarize the main points of the lecture.
- Use verbal cues for important ideas and to help. ("The next important idea is...")
- Stand near the student when presenting information.
- Cue student regularly by asking questions, giving time to think, then calling student's name.
- Minimize requiring the student to read aloud in class.
- Use memory devices (mnemonic aids) to help students remember facts and concepts.
- Allow student to tape the class.
- Additional accommodations may be needed.

Curriculum Strategies

- Help provide supplementary materials that student can read.
- Provide Parallel Alternative Strategies for Students (PASS) materials.
- Provide partial outlines of chapters, study guides, and testing outlines.
- Provide opportunities for extra drill before tests.
- Reduce quantity of material (i.e., reduce spelling/vocabulary lists, reduce number of math problems, etc.).
- Provide alternative assignments that do not always require writing.
- Supply student with samples of work expected.
- Encourage good quality of work (which involves proofreading, rewriting), not speed.
- Use worksheets that are visually clear and adequately spaced. Student may not be able to copy accurately or fast enough from the board or book; make arrangements for student to get information.
- Encourage the use of graph paper to align numbers.
- Make specific comments to correct responses on written or verbal class work.
- Allow students to have sample or practice test.
- Provide all possible test items and student or teacher selects specific number. Give oral examinations and quizzes.
- Provide extra assignment/test time.
- Accept some homework papers dictated by the student and recorded by someone else.
- Do not require lengthy outside reading.
- Provide study skills training/learning strategies.
- Arrange to offer extra study time with student on specific days and times.
- Do not count off for spelling errors.
- Allow access to computers for in-class writing assignments.
- Allow student to have someone edit papers.
- Allow student to use fact sheet/tables/charts.
- Tell student in advance what questions will be asked.
- Color code steps in a problem.
- Provide list of steps that will help organize information and facilitate recall.
- Assist in accessing taped texts.
- Reduce the reading level of assignments.
- Provide opportunity for student to restate assignment directions and due dates.
- Additional accommodations may be needed.

Testing Modifications

- Allow extended time for tests in the classroom and/or in the ESE support lab.
- Provide adaptive tests in the classroom and/or in the ESE support lab (reduce amount to read, cut and paste a modified test, shorten, revise format, etc.).
- Allow open book/open note tests in the classroom and/or ESE support lab.
- Allow student to take tests in the ESE support lab for help with reading and directions.
- Allow student to take tests in the ESE support lab with allotted time to study.
- Allow student to take tests in the ESE support lab using a word bank of answers or other aid as mutually agreed.
- Allow student to take tests orally in the ESE support lab.
- Allow the use of calculators, dictionaries, or spell checkers on tests in the ESE support lab.
- Provide alternative to testing (oral reports, making bulletin board, poster, audiotape, demonstration, all notes on chapters, etc.).
- Provide enlarged copies of the answer sheets.
- Allow copy of tests to be written upon and later have someone transcribe the answers.
- Allow and encourage the use of a blank piece of paper to keep pace and eliminate visual distractions on the page.
- Do not penalize for incorrect spelling.
- Provide alternate test formats for spelling/vocabulary tests.
- Highlight operation signs, directions, etc.
- Allow students to tape record answers to essay questions.
- Use more objective items (fewer essay responses).
- Give frequent short quizzes, not long exams.
- Additional accommodations may be needed.

Evaluation Criteria Modifications

- Student is on an individualized grading system.
- Student is on a pass/fail system.
- Student should be graded more on daily work and notebook than on tests (i.e., 60% daily, 25% notebook, 15% tests).
- Student will have flexible time limits to extend completion of grading into next grading period.
- Additional accommodations may be needed.

SAT Vocabulary Word List

Below is a list of words which occur most frequently on the SAT.

aberrant	articulate	censure
abstain	ascetic	chaos
abstruse	ascribe	cherubic
accolades	assuage	chronic
acquiesce	atheist	circumlocutory
acute	atrophy	clemency
adage	augment	coalesce
admonish	auspicious	coddle
adroit	autocrat	coerce
adulterate	aversion	cognizant
adversity	babble	commensurate
advocate	banal	compatible
aesthetic	barren	competent
affable	belittle	complacent
aggressive	belligerent	comply
alienate	benefactor	comprehensive
alleviate	benevolent	concise
alloy	benign	congenital
allusion	biased	conscientious
aloof	bizarre	contemplation
altruistic	bland	contempt
ambiguous	blasphemous	contend
ambivalent	blithe	contrite
ambulatory	blunder	controversy
ameliorate	bombastic	copious
amiable	brawny	corpulent
amity	brevity	corroborate
anarchy	brittle	credulous
anecdote	broach	crescendo
animosity	bureaucracy	cynical
annihilate	cacophony	dawdle
anonymous	cajole	dearth
antagonist	callous	deceit
antidote	callow	decorous
apathy	clamor	defer
apocryphal	candid	definitive
appease	capricious	degrading
arbitrary	caustic	delectable
arid	celestial	demise
arrogant	censor	deplete

deplore
depravity
deprecate
derision
desiccate
desist
desolate
despondent
despot
destitute
deter
deteriorate
detest
detriment
devious
didactic
diffident
digress
diligent
dilute
diminish
din
discern
discord
discreet
discursive
disdain
disgruntled
disinterested
disparage
disparity
disperse
disrepute
dissemble
dissonant
distended
distort
distraught
diversity
divert
divulge
dogmatic
drone

dubious
duplicity
dynamic
eccentric
ecstatic
edifying
efface
effervescent
elated
elicit
elucidate
elusive
emaciated
embellish
embezzle
emend
emulate
enervate
engender
enhance
enigma
enthrall
ephemeral
epitome
equivocate
eradicate
erratic
erroneous
erudite
esoteric
euphonious
evade
evoke
exacerbate
exasperated
exemplify
exigency
exorbitant
exorcise
expedient
expedite
explicit
expunge

extol
extraneous
extravagant
extricate
extrovert
facilitate
faction
fallacious
fallible
fanatic
fastidious
felicitous
fervent
fidget
fiendish
inscrutable
flagrant
flaunt
fledgling
flippant
flourish
forestall
formidable
frugal
furtive
garble
garner
glut
gratuitous
gravity
grovel
guile
gullible
hackneyed
harass
hedonism
heretic
heterogeneous
hierarchy
hone
hostile
hyperbole
hypocritical

hypothesis	labyrinth	perfunctory
idiosyncrasy	laconic	peripheral
illusory	lament	perpetual
immutable	languid	persevere
impassive	laudable	perspicacious
impecunious	lethargic	pertinent
impede	levity	pervade
imperturbable	listless	pessimist
implicit	lofty	petty
imply	luminous	philanthropic
impregnable	luxurious	philistine
inadvertent	malicious	pious
incessant	mar	placate
incisive	meander	plagiarism
incoherent	mediocre	platitude
incongruous	meticulous	plausible
indifferent	minuscule	pompous
indolent	misconstrue	ponderous
induce	miser	potent
inept	mitigate	pragmatic
inert	mobile	precipitate
infamous	munificent	preclude
infer	nefarious	precocious
infiltrate	novice	preeminent
ingenuous	noxious	premise
innate	nuance	prestige
innocuous	nullify	pretentious
innovation	obese	prevalent
inquisitive	objective	procrastinate
insatiable	obscure	prodigal
insinuate	obsolete	prodigy
insipid	obstinate	profuse
insoluble	officious	prolific
insolvent	opulent	propriety
insurgent	ostentatious	prosaic
intemperate	pacifist	protracted
intractable	pariah	provincial
intricate	parody	provoke
irascible	parsimonious	prudent
irony	pathetic	punctual
irrevocable	patronize	pungent
jeopardize	paucity	querulous

raconteur
rancid
ratify
rational
ravenous
raze
rebuttal
recalcitrant
redundant
refute
reiterate
rejuvenate
relegate
relevant
renegade
renovate
repository
reprehensible
reproach
repudiate
repulse
rescind
resilient
resourceful
respite
restrained
retaliate
reticent
retract
reverent
rigorous
ruthless
saccharine
sagacious
savory
scanty
scrupulous
scrutinize
sentimental
sequester
serene
servile

sever
skeptical
slothful
sluggish
sobriety
solemn
solicit
solvent
somber
sophisticated
soporific
sparse
spurious
squalid
squander
stagnant
steadfast
stoic
stringent
strut
stultifying
suave
subjective
subordinate
subtle
sullen
supercilious
superficial
superfluous
surlly
surmise
surreptitious
susceptible
sycophant
symmetry
synonymous
tactful
taper
tardy
taut
tedious
tentative

terminate
tirade
torpid
tranquil
trivial
turgid
unanimous
unassailable
unceremonious
unflinching
unobtrusive
unprecedented
upbraid
vacillate
vagrant
valiant
valid
variegated
venerate
venturesome
verbose
verify
versatile
viable
vibrant
vicarious
vigilant
vigorous
vilify
vindicate
virtuoso
virulent
vivacious
volatile
voluminous
voracious
vulnerable
whet
zeal
zenith

Correlation to Sunshine State Standards

Standards		
1. Use reading strategies effectively to construct meaning from a range of technical, informative, and literary texts.		
Benchmarks	Addressed in Unit(s)	Addressed in Class on Date(s)
LA.A.1.4.1 Select and use prereading strategies that are appropriate to the text, such as discussion, making predictions, brainstorming, generating questions, and previewing to anticipate content, purpose, and organization of a reading selection.	1, 5	
LA.A.1.4.2 Select and use strategies to understand words and text, and to make and confirm inferences from what is read, including interpreting diagrams, graphs, and statistical illustrations.	1	
LA.A.1.4.3 Refine vocabulary for interpersonal, academic, and workplace situation, including figurative, idiomatic, and technical meanings.	1, 2, 4, 6	
LA.A.1.4.4 Apply a variety of responses strategies, including rereading, note taking, summarizing, outlining, writing a formal report, and relating what is read to his or her own experiences and feelings.	1, 2	
LA.A.2.4.1 Determine the main idea and identify relevant details, methods of development, and their effectiveness in a variety of types of written material.	1	
LA.A.2.4.2 Determine the author's purpose and point of view and their effects on text.	1, 5	
LA.A.2.4.4 Locate, gather, analyze, and evaluate written information for a variety of purposes, including research projects, real-world task, and self-improvement.	1, 6	
LA.A.2.4.5 Identify devices of persuasion and methods of appeal and their effectiveness.	2, 4	
LA.A.2.4.6 Select and use appropriate study and research skills and tools according to the type of information being gathered or organized, including almanacs, government publications, microfiche, news sources, and information services.	1, 6	
LA.A.2.4.7 Analyze the validity and reliability of primary source information and use the information appropriately.	1, 4, 6	
LA.A.2.4.8 Synthesize information from multiple sources to draw conclusions.	1, 6	

Correlation to Sunshine State Standards

Standards		
2. Use process writing strategies effectively to meet the needs of a variety of audiences, writers, and types of information being communicated.		
Benchmarks	Addressed in Unit(s)	Addressed in Class on Date(s)
LA.B.1.4.1 Select and use appropriate prewriting strategies, such as brainstorming, graphic organizers, and outlining.	2, 6	
LA.B.1.4.2 Draft and revise writing that <ul style="list-style-type: none"> • is focused, purposeful, and reflects insight into the writing situation; • has an organizational pattern that provides for a logical progression of ideas; • has effective use of transitional devices that contribute to a sense of completeness; • has support that is substantial, specific, relevant, and concrete; • demonstrates a commitment to and involvement with the subject; • uses creative writing strategies as appropriate to the purpose of the paper; • demonstrates a mature command of language with precision of expression; • has varied sentence structure; and • has few, if any, convention errors in mechanics, usage, punctuation, and spelling. 	2, 3, 6	
LA.B.1.4.3 Produce final documents that have been edited for <ul style="list-style-type: none"> • correct spelling; • correct punctuation, including commas, colons, and common use of semicolons; • correct capitalization; • correct sentence formation; • correct instances of possessives, subject/verb agreement, instances of noun/pronoun agreement, and the intentional use of fragments for effects; and • correct formatting that appeals to readers, including appropriate use of a variety of graphics, tables, charts and illustrations in both standard and innovative forms. 	3, 6	
LA.B.2.4.2 Organize information using appropriate systems.	2, 6	
LA.B.2.4.3 Write fluently for a variety of occasions, audiences, and purposes, making appropriate choices regarding style, tone, level of detail, and organization.	2, 6	

Correlation to Sunshine State Standards

Standards		
3. Select and use appropriate speaking, listening, and viewing skills to clarify and interpret meaning in both formal and informal situations.		
Benchmarks	Addressed in Unit(s)	Addressed in Class on Date(s)
LA.C.1.4.1 Select and use appropriate listening strategies according to the intended purpose, such as solving problems, interpreting and evaluating the techniques and intent of a presentation, and take action in career-related situations.	4	
LA.C.1.4.2 Describe, evaluate, and expand personal preferences in listening to fiction, drama, literary nonfiction, and informational presentations.	4, 5	
LA.C.1.4.3 Use effective strategies for informal and formal discussions, including listening actively and reflectively, connecting to and building on the ideas of a previous speaker, and respecting the viewpoints of others.	4	
LA.C.1.4.4 Identify bias, prejudice, or propaganda in oral messages.	4	
LA.C.2.4.1 Determine main concept and supporting details in order to analyze and evaluate nonprint media messages.	4	
LA.C.2.4.2 Understand factors that influence the effectiveness of nonverbal cues used in nonprint media, such as the viewer's past experiences and preferences, and the context in which the cues are presented.	4	
LA.C.3.4.1 Use volume, stress, pacing, enunciation, eye contact, and gestures that meet the needs of the audience and topic.	4	
LA.C.3.4.2 Select and use a variety of speaking strategies to clarify meaning and to reflect understanding, interpretation, application, and evaluation of content, processes, or experiences (including asking relevant questions when necessary, making appropriate and meaningful comments, and making insightful observations).	4	
LA.C.3.4.3 Use details, illustrations, analogies, and visual aids to make oral presentations that inform, persuade, or entertain.	4	
LA.C.3.4.4 Apply oral communication skills to interviews, group presentations, formal presentations, and impromptu situations.	4	
LA.C.3.4.5 Develop and sustain a line of argument and provide appropriate support.	4	

Correlation to Sunshine State Standards

Standards		
4. Understand the common features of a variety of literary forms.		
Benchmarks	Addressed in Unit(s)	Addressed in Class on Date(s)
LA.E.1.4.1 Identify the characteristics that distinguish literary forms.	5	
LA.E.1.4.3 Identify universal themes prevalent in the literature of all cultures.	5	
LA.E.1.4.4 Understand the characteristics of major types of drama.	5	
LA.E.1.4.5 Understand the different stylistic, thematic, and technical qualities present in the literature of different cultures and historical periods.	5	

Standards		
5. Respond critically and aesthetically to literature.		
Benchmarks	Addressed in Unit(s)	Addressed in Class on Date(s)
LA.A.2.4.3 Describe and evaluate personal preferences regarding fiction and nonfiction.	5	
LA.E.2.4.1 Analyze the effectiveness of complex elements of plot, such as setting, major events, problems, conflicts, and resolutions.	5	
LA.E.2.4.2 Understand the relationships between and among elements of literature, including characters, plot, setting, tone, point of view, and theme.	5	
LA.E.2.4.3 Analyze poetry for the ways in which poets inspire the reader to share emotions, such as the use of imagery, personification, and figures of speech, including simile and metaphor, and the use of sound, such as rhythm, repetition, and alliteration.	5	
LA.E.2.4.6 Recognize and explain those elements in texts that prompt a personal response, such as connections between one's own life and the characters, events, motives, and causes of conflict in texts.	5	

Correlation to Sunshine State Standards

Standards		
6. Demonstrate understanding and use of appropriate language for effective visual, oral, and written communication.		
Benchmarks	Addressed in Unit(s)	Addressed in Class on Date(s)
LA.D.1.4.1 Apply an understanding that language and literature are primary means by which culture is transmitted.	4, 5	
LA.D.1.4.2 Make appropriate adjustments in language use for social, academic, and life situations, demonstrating sensitivity to gender and cultural bias.	4, 6	
LA.D.2.4.1 Understand specific ways in which language has shaped the reactions, perceptions, and beliefs of the local, national, and global communities.	4	
LA.D.2.4.2 Understand the subtleties of literary devices and techniques in the comprehension and creation of communication.	1, 2, 4, 5	

Standards		
7. Select and use a variety of electronic media to create, revise, retrieve, and verify information.		
Benchmarks	Addressed in Unit(s)	Addressed in Class on Date(s)
LA.B.2.4.1 Write text, notes, outlines, comments, and observation that demonstrate comprehension and synthesis of content, processes, and experiences from a variety of media.	2, 6	
LA.B.2.4.2 Organize information using appropriate systems.	2, 6	
LA.B.2.4.4 Select and use a variety of electronic media, such as the Internet, information services, and desktop-publishing software programs, to create, revise, retrieve, and verify information.	6	

Correlation to Sunshine State Standards

Standards		
8. Demonstrate understanding of the impact of mass media and the regulations that govern its use.		
Benchmarks	Addressed in Unit(s)	Addressed in Class on Date(s)
LA.D.2.4.5 Critically analyze specific elements of mass media with regard to the extent to which they enhance or manipulate information.	1, 4	
LA.D.2.4.6 Understand that laws control the delivery and use of media to protect the rights of authors and the rights of media owners.	4, 6	

References

- Ackerman, Diane. *The Moon by Whale Light*. New York: Vintage-Random, 1991.
- Arolimek, John, et al. *World Neighbors*. New York: Macmillan, 1985.
- Applebee, Arthur N., et al. *The Language of Literature*. Evanston, IL: McDougal Littell, 1997.
- Armstrong, Thomas. *Multiple Intelligences in the Classroom*. Alexandria, VA: Association for Supervision and Curriculum Development, 1994.
- Beane, James A., ed. *Toward a Coherent Curriculum*. Alexandria, VA: Association for Supervision and Curriculum Development, 1995.
- Berbrich, Joan D. *Fifteen Steps to Better Writing*. New York: Amsco School Publications, 1988.
- Berbrich, Joan D. *Writing Practically*. New York: Amsco School Publications, 1994.
- Bowler, Ellen, ed. *Prentice-Hall Literature World Masterpieces*. Saddle River, NJ: Prentice-Hall, 1996.
- Christ, Henry I. *Building Power in Writing*. New York: Amsco School Publications, 1992.
- Florida Department of Education. *Florida Curriculum Framework: Language Arts*. Tallahassee, FL: State of Florida, 1996.
- Florida Department of Education. *Florida Writes! Report on the 1996 Assessment*. Tallahassee, FL: State of Florida, 1996.
- Gardner, Lewis, ed. *Scope English Anthology (Level Five)*. New York: Scholastic, 1984.
- Gardner, Lewis, ed. *Scope English Anthology (Level Four)*. New York: Scholastic, 1984.
- Gardner, Lewis, ed. *Scope English Anthology (Level Three)*. New York: Scholastic, 1983.

- Gill, Kent and Jackie Proett. *The Writing Process in Action*. Urbana, IL: National Council of Teachers of English, 1986.
- Golub, Jeff, et al. *Activities to Promote Critical Thinking*. Urbana, IL: National Council of Teachers of English, 1986.
- Harmin, Merrill, *Inspiring Active Learners: A Handbook for Teachers*. Alexandria, VA: Association for Supervision and Curriculum Development, 1994.
- Hutchinson, Jamie, ed. *Teaching Literature in High School: The Novel*. Urbana, IL: National Council of Teachers of English, 1995.
- Hutchinson, Jamie, ed. *Teaching the Writing Process in High School*. Urbana, IL: National Council of Teachers of English, 1995.
- Johnson, Elaine, ed. *American Literature for Life and Work*. Cincinnati, Ohio: South-Western Educational Publishing, 1997.
- Kaiman, Amy Bunin. *Florida's HSCT: Preparing for the Communications Test*. New York: Amsco School Publications, 1996.
- Kaiman, Amy Bunin. *Preparing for the Florida Writing Assessment Test, Secondary Level*. New York: Amsco School Publications, 1997.
- Krenzke, Lois, et al. *Writers INC*. Boston: D.C. Heath, 1996.
- Langer, Judith, ed. *Literature Instruction: A Focus on Student Response*. Urbana, IL: National Council of Teachers of English, 1986.
- Lloyd-Kolkin, Donna and Kathleen R. Tyner. *Media and You*. Englewood Cliffs, NJ: Strategies for Media Literacy, 1991.
- National Council of Teachers of English and International Reading Association. *Standards for the English Language Arts*. Urbana, IL: National Council of Teachers of English, 1995.
- Noguchi, Rei R. *Grammar and the Teaching of Writing*. Urbana, IL: National Council of Teachers of English, 1991.
- Oliver, Eileen Iscoff. *Crossing the Mainstream: Multicultural Perspectives in Teaching Literature*. Urbana, IL: National Council of Teachers of English, 1994.

Schumaker, Jean B. and Jan Sheldon. *The Sentence Writing Strategy*.
Lawrence, KS: The University of Kansas, 1985.

Sebranek, Patrick, et al. *Write Source 2000*. Boston: D.C. Heath, 1995.

Snow, Robert A. *Advanced Reading Skills*. New York: Amsco School
Publications, 1994.

Sorenson, Sharon. *Composition: Prewriting, Response, Revision*. New York:
Amsco School Publications, 1994.

Tachudi, Stephen. *Planning and Assessing the Curriculum in English
Language Arts*. Alexandria, VA: Association for Supervision and
Curriculum Development, 1991.

Production Software

Macromedia Freehand 5.0. San Francisco: Macromedia.

Adobe PageMaker 6.0. Salinas, CA: Adobe Systems.

Microsoft Word 5.0. Redmond, WA: Microsoft.



Affirmative action/equal opportunity employer
Frank T. Brogan, Commissioner

ESE 5185.A

SCOPE OF INTEREST NOTICE

The ERIC Facility has assigned this document for processing to:

EC

In our judgment, this document is also of interest to the Clearinghouses noted to the right. Indexing should reflect their special points of view.

CS

English I

Course No. 1001310



Bureau of Instructional Support and Community Services
Division of Public Schools and Community Education
Florida Department of Education
1998

Parallel
Alternative
Strategies for
Students

This is one of many publications available through the Bureau of Instructional Support and Community Services, Florida Department of Education, designed to assist school districts, state agencies which support educational programs, and parents in the provision of special programs. For additional information on this publication, or for a list of available publications, contact the Clearinghouse Information Center, Bureau of Instructional Support and Community Services, Division of Public Schools and Community Education, Florida Department of Education, Room 628 Turlington Bldg., Tallahassee, Florida 32399-0400.

telephone: (850) 488-1879

FAX: (850) 487-2679

Suncom: 278-1879

e-mail: cicbiscs@mail.doe.state.fl.us

Web site: <http://www.firn.edu/doe/commhome/>

English I

Course No. 1001310

Bureau of Instructional Support and Community Services
Division of Public Schools and Community Education
Florida Department of Education

Reprinted 2001

This product was developed by Leon County Schools, Exceptional Student Education Department, through the Curriculum Improvement Project, funded by the State of Florida, Department of Education, Division of Public Schools and Community Education, Bureau of Instructional Support and Community Services, through federal assistance under the Individuals with Disabilities Education Act (IDEA), Part B.

Copyright
State of Florida
Department of State
1998

Authorization for reproduction is hereby granted to the State System of Public Education as defined in Section 228.041(1), Florida Statutes. No authorization is granted for distribution or reproduction outside the State System of Public Education without prior approval in writing.



English I

Course No. 1001310

edited by

Jeren Goldstein

graphics by

**Rachel McAllister
Laurie M. Herring
Portia R. Thomas**

Curriculum Improvement Project
IDEA, Part B, Special Project



Exceptional Student Education

Curriculum Improvement Project

Sue Fresen, Project Manager

Leon County Exceptional Student Education (ESE)

Ward Spisso, Director of Exceptional Education and Student Services

Diane Johnson, Director of the Florida Diagnostic and Resources Learning
System (FDLRS)/Miccosukee Associate Center

School Board of Leon County

Tom Young, Chair

Joy Bowen

J. Scott Dailey

Maggie Lewis

Fred Varn

Superintendent of Leon County Schools

William J. Montford

Table of Contents

Acknowledgments	vii
Introduction	ix
Unit 1: Reading—Becoming a Word Detective	1
Overview	3
Vocabulary	5
Previewing: Looking Ahead	7
Understanding Words and Their Meanings: Using Clues to Discover Meanings	15
The Main Idea: Getting the Big Point	35
Literal and Figurative Language: Language That Points and Language That Paints	38
Understanding Visual References: Reading the Guides	43
Finding Information: Identifying the Right Source	59
Responding to What You Read: Interacting with Material	71
Evaluating What You Read: Recognizing Fact and Opinion	77
Unit 2: Writing—Making Words Speak	81
Overview	83
Vocabulary	85
Prewriting: Sharpening Your Point, Gathering Materials	87
Gathering Information: Going to the Right Source	90
Organizing Information: Each in Its Own Place	95
Writing for an Audience: Tailoring Your Words and Content to Fit Readers	101
Writing a First Draft: Beginning to “Speak” to Your Readers	107
Paragraph Types: Explaining and Persuading	112
Unit 3: Writing—Taking a Second Look	131
Overview	133
Vocabulary	135
Revising: Adjusting the Picture	137
Editing: Focusing in on Grammar, Punctuation, and Spelling	145
Complete and Incomplete Sentences: Finished and Unfinished Thoughts ..	151
Correcting Run-on Sentences: When Words Run Stop Signs	154
Subject and Verb Agreement: Matching the Doer and Its Action	160
Regular and Irregular Verbs: Hard Working Words	165
Nouns: Plural or Singular?	170
Noun and Pronoun Agreement: Drawing a Strong Link	178
Possessives: Showing Ownership	182
Capitalization: Upper Case Rules	186

Punctuation: Roadsigns to Guide Readers	191
Spelling: Writing it Right!	198
Proofreading: The Final Check	200
Unit 4: Listening, Viewing, Speaking—Communicating	
Face-to-Face	209
Overview	211
Vocabulary	213
Selecting a Good Story: Matching a Story to Your Audience	215
Using Effective Visual Aids: Adding Highlights to a Story	221
Using Effective Presentation Skills: Using Your Voice and Body	224
Persuasion Techniques: Pressing Our Buttons	231
Discussion Skills: The Art of Listening and Speaking in a Group	239
Active Listening: Absorbing Information and Ideas	240
Unit 5: Literature: Discovering the World, Discovering	
Ourselves	243
Overview	245
Vocabulary	247
Fiction and Nonfiction: The Imagined and the Real	251
Common Literary Elements: The Parts that Make Literature Go	261
Universal Themes: Ideas We All Live By	267
Short Story: Compressing the Conflict	275
Novel: Fully Developed Characters Amidst a Host of Conflicts	279
Poetry: Tasting Words	289
Drama: A Story Told by Actors in Action	301
Autobiography and Biography: Stories about a Life	315
Critical Analysis: Examining the Parts to Judge the Whole	319
Unit 6: Integrating Online Technology—Using the Information	
Highway	323
Overview	325
Vocabulary	327
The Information Highway: A New Mode of Travel	329
Search Engines: How to Find a Needle in a Haystack	332
Internet Searching and Boolean Wording: Narrowing Your Search	335
Sending and Receiving Electronic Mail: The Computer Postal Service	337
Citing Electronic References: Giving Credit Where Credit is Due	340
Appendices	347
Index	349
References	351

Acknowledgments

The staff of the Curriculum Improvement Project wishes to express appreciation to the curriculum writers and reviewers for their assistance in the development of *English I*. We also wish to express our gratitude to educators from Duval, Leon, and Wakulla county school districts for the initial *Parallel Alternative Strategies for Students (PASS) English I Skills* books.

Curriculum Writers

Missy Atkinson
Technology Coordinator
Godby High School
Tallahassee, FL

Jeren Goldstein
Writer/Editor
Page Perfect
Tallahassee, FL

Lee Ann McCombs
ESE Teacher
Pembroke Pines, FL

Janice McLain
English Teacher
Leon High School
Tallahassee, FL

Karen Nicholas
ESE Teacher
Florida State University
Developmental School
Tallahassee, FL

Review Team

Kathy Sciara
English Teacher
Rickards High School
Tallahassee, FL

Deborah Shepard
English Teacher
Lincoln High School
Tallahassee, FL

Production Staff

Sue Fresen, Project Manager
Blanche Blank, Text Design Specialist
Rachel McAllister, Graphic Design Specialist
Curriculum Improvement Project
Leon County Schools
Tallahassee, FL

Introduction

Imagine your world without language ...

No rap, no love letters, no poetry to move the soul, no debates, no magazines, no recipes, no torrid tales, no jokes, no lyrics, no notes to be passed in class, no talks with your best friend, nothing to remember from one generation to another. Get the picture? Pictures are all you would get or give, plus a couple of grunts and gestures here and there.

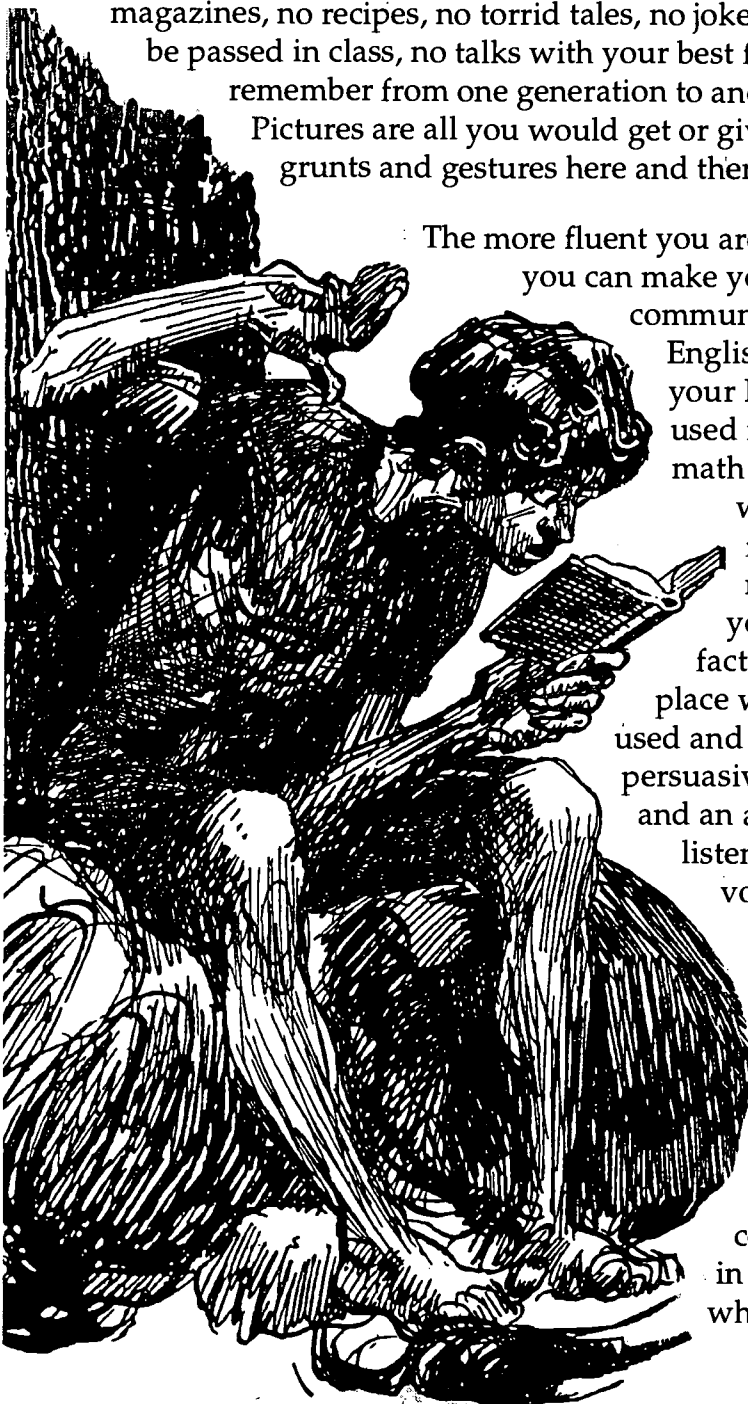

The more fluent you are in English, the more you can make your voice heard in your communities. Think about it.

English is not confined to your English classroom. It is used in your biology and math classes, in the business world, and on sports fields. It is used in your neighborhood and in your circle of friends. In fact, it is hard to think of a place where language is not used and valued. Being a persuasive writer and speaker, and an astute reader and listener will enable you to vote more intelligently, speak more confidently, and reveal more of your true self to loved ones. To those ends, this book is offered as an introduction to the skills you'll need to communicate effectively in all the communities in which you live.

An explanation on how this book is organized ...

The skills you need to operate well in the world of language have been divided into six units. Each unit is broken down into a series of steps that will help you learn, practice, and apply necessary skills. The series of steps moves towards a final project in which you can demonstrate your command of the subject of each unit.

Unit 1 is entitled “Reading—Becoming a Word Detective” because the good reader operates like a good detective. The good reader expects to come across many mysteries on the page. He knows that there are strategies he can use to solve unfamiliar content and unknown words. Once you fully understand a written work, you can begin to make use of it for your own purposes.

Unit 2 is entitled “Writing—Making Words Speak” because the good writer makes her words speak to her readers. She knows that her readers are real people, and she writes to them—not to a blank wall. Knowing that her readers are real people, she tries to identify how much they know on the subject she is writing about. She builds on her readers’ knowledge and chooses language that they can understand. Her purpose is to inform or entertain her readers, and she knows she cannot accomplish either without studying both her subject and her audience.

Unit 3 is entitled “Writing—Taking a Second Look” because even the very best writers write more than one draft. Good writers know that a first draft begins to speak to their readers, but that some fine tuning can improve any piece of writing. Good writers respect their readers and want to give them the very best piece of writing they can.

Unit 4 is entitled “Listening, Viewing, Speaking—Communicating Face-to-Face” because whether you are listening to or giving a formal presentation, or participating in a casual discussion, your spoken language and your body language must work together if you are to be effective in face-to-face communication. Even the best spoken words will land with a thud if you don’t complement them with the right body language. When you are face-to-face with a speaker or listener, there’s no paper to hide behind.

Unit 5 is entitled “Literature—Discovering the World, Discovering Ourselves” because literature is a tool with which to explore both foreign worlds and the familiar self. Using this tool well takes more than just reading the words in a poem or story. Literature uses familiar words but

puts them together in some unfamiliar ways. With some guidance, you can learn to use literature to light up new worlds or to cast fresh light on familiar ones.

Unit 6 is entitled “Integrating Online Technology—Using the Information Highway” because if you don’t learn how to use the Information Highway when you go online, you will find yourself lost. The Information Highway and the Internet are a maze of roads and symbols. The guidance and map you get in this unit will help you locate what you want amongst the millions of destinations in this new technological galaxy.

Whether you notice it or not, each time you talk or write well about any subject or topic, you use particular words or terms. Think of a subject you know well and imagine trying to discuss it without using special terms. Think of how many words you’d have to use if you couldn’t use the word *scale* when discussing music or the word *Internet* when discussing the uses of computers. Similarly, the subject of each unit in this book has its own special vocabulary. The beginning of each unit in this book has a list of essential vocabulary terms for that unit’s subject. These terms are **bolded** the first time they are used in the unit’s discussion. Make sure you understand each bolded term clearly before you move on. Without a good working knowledge of these terms, the language of this book will begin to sound ... well, like a foreign language.

Practice and *Application* activities have been included in each unit so you can measure your comprehension of the various skills presented. The bolded term or terms in the directions of each *practice* or *application* describe the skill that is being presented. The good student knows that getting a high score on these activities is only half the task. The other half is knowing why your answers were correct or incorrect. In short, use these activities to demonstrate your new-found knowledge rather than to show your ability to guess well.

A note on how to make this book work for you ...

Lastly, bring your best attitude along as you move through this book. The writers of this book have tried to use a friendly and engaging style and format as they lead you through the steps of becoming a good reader, writer, listener, and speaker. But remember: The words on the following pages will just lie there until you add your interest and breathe life into them.

Unit 1: Reading— Becoming a Word Detective

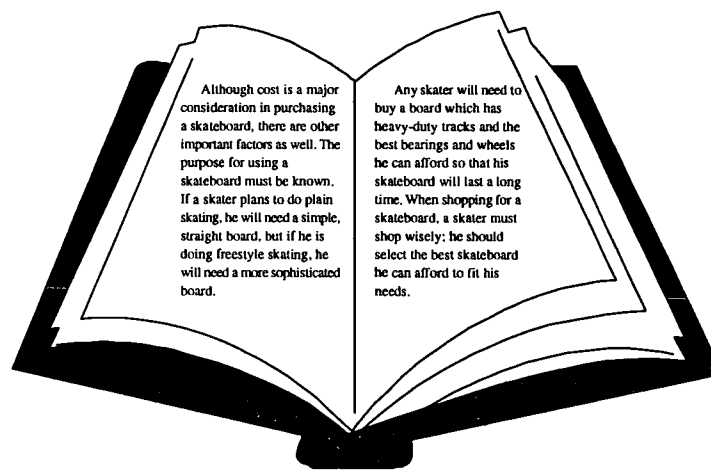



Unit 1: Reading—Becoming a Word Detective

Overview

We are bombarded daily with things to read—billboards, directories, newspapers, stories, advertisements, etc. Regardless of your life's work or leisure activities, being a good reader is very important. Good readers do more than pronounce words. They use various strategies to help them understand the meaning of what they are reading, evaluate what they are reading, and find specific information in various written resources.

In this unit you will practice and apply reading strategies effectively to understand and use a wide range of technical, informative, and literary texts. The unit starts with previewing because previewing is the first thing that good readers do. It is helpful to all readers to get an overview of the material they are going to read before they start to read. The unit continues with lessons on the skills needed to understand the meaning of written words in literary texts and of visual references such as charts, graphs, and directories.

The next section of this unit provides practice in finding and understanding information. A flow chart is included that identifies particular kinds of information and corresponding resources. This section ends with an application that asks you to find information that answers a list of questions. You may be surprised at some of the answers you find when completing this information scavenger hunt.

After you have learned to make sense of the words and symbols on a page, the next step is to turn your reading into forms that fit your needs. One useful form, especially to the student, is a summary. This unit will guide you through the skills you need to produce a written summary.

Many of the things you read are written by people who hope to convince you that one idea or product is better than another. Good readers are able to evaluate what they are reading so they can make good choices in their daily lives. Therefore, the final section provides a list of questions to ask when evaluating something you are reading. At the end of this unit you will be asked to evaluate two editorials that are written on the same topic. This project will help you demonstrate many of the skills you will develop as you progress through this unit.



Vocabulary

Study the vocabulary words and definitions below.

connotations meanings that come from the emotions or ideas readers associate with particular words

figurative language uses words in such a way that the reader sees something special or feels a particular way

index located at the end of a book; it gives an alphabetical listing of all subjects covered in the book and page numbers where the subject appears

literal language uses words for their exact meaning—the meaning found in the dictionary

main idea the most important idea or point in a paragraph or piece of writing

metaphors a comparison between two different or unlike things
*Example: calling a life change *turning over a new leaf**

onomatopoeia the use of words that sound like their meanings
Examples: ooze, slurp, thud



- personification** an expression that gives a human characteristic or action to an object
Example: The truck *crawled* up the mountain road.
- preview** to look at in advance to get an idea of what is to come
- similes** a comparison between two different or unlike things using the word *like* or *as*
Example: That chair is not heavy, that chair is *light as a feather*.
- summary** a brief outline of the structure and central ideas of a piece of writing
- table of contents** located at the front of a book; it shows how the book is organized and gives pages numbers of chapters and subtopics within those chapters
- visual references** summarizing and supplementing written information with sources such as directories, diagrams, tables, graphs, schedules, pictures, maps, or signs



Previewing: Looking Ahead

Smart drivers consult road maps and travel information before they take a trip. Smart cooks read through their recipes before they cook. Smart students **preview** their materials before they begin to read. Previewing helps you discover the writer's purpose and prepares you to understand what you are going to read. Previewing helps you organize and interpret information right from the start so you read more efficiently.

Complete the following steps and answer the corresponding questions when previewing reading materials.

Previewing Reading Materials

1. **Read the title.** What is the *general subject* of the material? On what *specific part* of the general subject will the material focus? Does the title tell you how the *author feels* about the subject?
2. **Skim through the selection, looking for chapter titles, headings, subheadings, etc.** How is the material divided? If it is a book, skim the **table of contents** for chapter titles. If it is a chapter or article, skim for headings and subheadings. What do these divisions tell us about the content of the article? Think of them as the bones or skeleton of the material. As you read, lay the information and ideas where they belong on the skeleton.
3. **Look at the illustrations.** If illustrations appear, what do they tell you about the subject?
4. **Read the opening paragraph.** How does the author feel about the subject? Is he or she presenting an *explanation* or making an *argument*?
5. **Read the closing paragraph.** What conclusions does the author draw about the subject?



Now read again the steps for previewing reading materials. Study the examples and analyses that follow each step.

Read the title. What is the *general subject* of the material? On what *specific part* of the general subject will the material focus? Does the title tell you how the *author feels* about the subject?

Take, for example, the title “Stop the Violence in Our Schools!” The general subject is *violence in our schools*. The author is focusing on a specific part of this subject: *stopping this violence*. The title also clearly tells us that the author feels strongly that we should *stop this violence!* Note how much information about the contents of this article you can get simply by reading the title carefully.

Skim through the selection, looking for chapter titles, headings, subheadings, etc. How is the material divided? If it is a book, skim the table of contents for chapter titles. If it is a chapter or article, skim for headings and subheadings. What do these divisions tell us about the content of the article? Think of them as the bones or skeleton of the material. As you read, lay the information and ideas where they belong on the skeleton.

The article “Stop the Violence in Our Schools!” was divided by the following headings: (1) “Why Teens Bring Violence to School”; (2) “What the School Can Do to Help Violent Students”; (3) “What the Family Can Do to Help Violent Children”; (4) “Why and How We Must Protect the Law-Abiding Student.”

Note that simply by reading these headings you get a sense of the content of the article. The author recognizes that there are reasons why students are violent in schools. The author also thinks that schools and families can help end the violence. In addition, the author believes that peaceful students must be protected from violent ones. These headings are a kind of map telling us where this discussion is going.

Look at the illustrations. If illustrations appear, what do they tell you about the subject?

The illustration included in the article “Stop the Violence in Our Schools!” shows a crowd of students watching two students fight. The illustration makes the point that violence detracts from education—the students in this picture are not in a classroom. When they return to the classroom, they may be distracted and upset by what they’ve seen.



Read the opening paragraph. How does the author feel about the subject? Is he or she presenting an *explanation* or making an *argument*?

Consider the following few lines from the opening paragraph of “Stop the Violence in Our Schools!”

One day Joseph just stopped going to school. He couldn't take it any longer. Each day had become a question mark: Would there be a fight today? Would someone pull a weapon? Would a gang surround a single unfortunate person? And yet, after staying a home for a few days, it dawned on Joseph—he was a lucky one. He was still unhurt, and he was still alive! Then he took action. He began to discover ways to help end the violence. He formed a mediation group that could help students settle their differences in nonviolent ways. He helped organize meetings where students could voice their fears and offer solutions.

The opening paragraph conveys just how serious and important the author feels this issue is. It is clearly an argument—stop the violence—but the article will most likely include explanations. The article is likely to explain, for example, how mediation groups can be formed and how they work.

Read the closing paragraph. What conclusions does the author draw about the subject?

Consider the following few lines from the closing paragraph of “Stop the Violence in Our Schools!”

Right now the amount of violence in many schools seems unstoppable. Short of turning schools into prisons, how can we stop the violence? The answer to this question is the same answer to most hard social issues—one person at a time, beginning with you and me. Even if you are about to graduate from school and escape the violence, you will most likely one day be packing your own children off to school. Do you want them to learn or to fight?

The author concludes that the problem will only be solved if we don't let the size of the problem overwhelm us. The conclusion is a plea for readers to take action to solve this problem.



Practice

Use the questions below to preview the article, "Viruses: The Tiny Saboteur," that follows.

1. Read the title.

What is the general subject of this article? _____

On what specific part of the general subject will this article focus?

Does the title tell how the author feels about the subject?

2. Skim through the selection, looking for chapter titles, headings, subheadings, etc.

How is the material divided? _____

What do these divisions tell us about the content of an article?

3. Look at the illustrations.

What do they tell you about the subject? _____



4. Read the opening paragraph.

How does the author feel about the subject?

Is the author treating the topic objectively or subjectively? (Is he or she presenting an *explanation* or making an *argument*?)

5. Read the closing paragraph.

What conclusions does the author draw about the subject?



Viruses: The Tiny Saboteur

Characteristics of Viruses

Viruses are strange little things that don't fall into any category. In fact, scientists have long argued about whether or not viruses are even alive. They are not made of cells, the basic unit of life. However, they do reproduce. Viruses reproduce by hijacking the equipment of living cells, basically taking over the cell and using its chemicals to make copies of themselves. As they reproduce, they kill the cell they have taken over. Obviously, viruses are consumers.

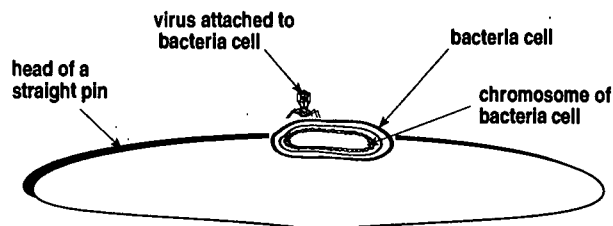

If viruses aren't made of cells, what are they made of? Basically, they're just a little bit of genetic material inside a protein capsule. They are very, very small—beyond extremely small—and can only be seen with very specialized microscopes. A virus operates by somehow tricking a cell into allowing it inside. Then it sabotages the cell by substituting its own genetic material for the cell's genetic material. It tricks the cell's machinery into making virus copies instead of cell copies.

Viruses and Illnesses

Viruses are very much in the news these days because of the human immunodeficiency virus (HIV), which attacks immune system cells and causes Acquired Immune Deficiency Syndrome (AIDS). Viruses are responsible for other familiar sicknesses, such as the common cold. Although scientists have developed vaccines to protect us against some viruses, they have not been able to develop vaccines to keep us safe from all of them.



Application

Select an article or chapter in a textbook to **preview**. Preview the article or chapter using the following form and extra paper if you need it. Use the steps and questions for "Previewing Reading Materials" on page 5 to guide you.

Preview Form

Title of Article or Chapter: _____

Author: _____



Understanding Words and Their Meanings: Using Clues to Discover Meanings

A writer uses words to “build” a phrase, sentence, paragraph, or essay, just as a builder uses clay, wood, or steel to erect a wall, room, or building. Skilled writers are aware of how to use these words to make readers feel a certain way or to understand different levels of meaning. Writers use words to make readers like or dislike a character, understand the true meaning of the text, and feel comfortable or uncomfortable in a reading situation.

Predicting Words: Which Words Belong to This Subject?

After you have previewed a reading selection, you should have a pretty good idea about the subject of the selection and the author’s attitude towards that subject. You will also have an idea about the kinds of words that you will find in the selection. For example, if you previewed a story about life on a farm you might expect to find words like *haystack*, *fertilizer*, *tractors*, *irrigation*, and so on.

Written material includes clues that help you predict words and meaning. This ability to predict and expect certain words helps readers move more quickly through the selection.

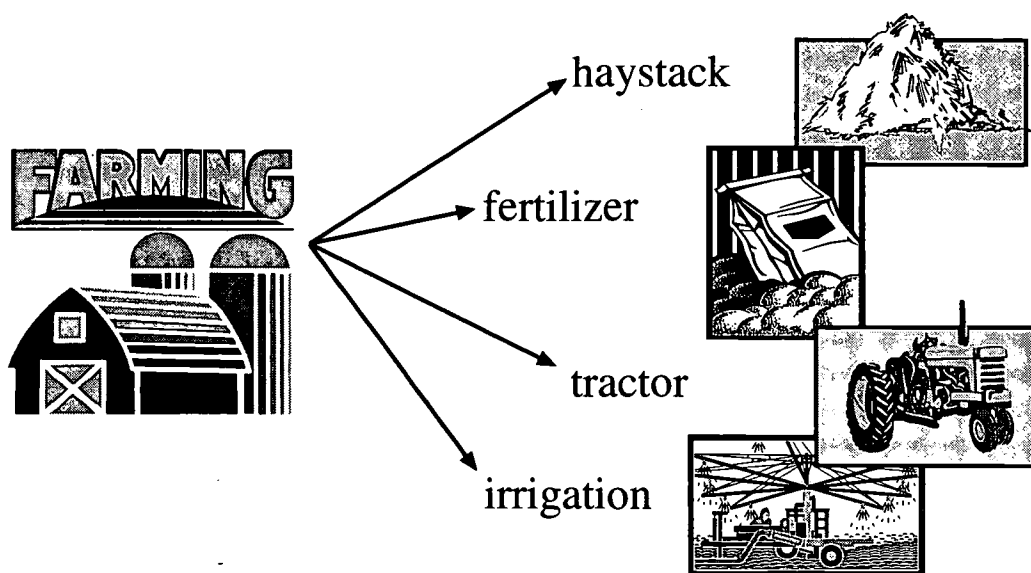



Practice

List four words you might expect to find in each of the following.

1. A story about the stock market crash of 1929.

2. A poem about a lost love.

3. An article on using the Internet.

4. An editorial about building more roads as a solution to traffic problems.

5. A brochure about a beach resort.



Practice

*Two of the words in the list below would **not** appear in an article about physical fitness. Circle the two words you would **not** expect to find in this selection.*

doctors	blood pressure	diabetes
exercise	dynamite	nutrition
obesity	running	investments
cholesterol	muscle tone	fat intake

Which of the following phrases would you expect to find in an article about baseball? Put an X in front of them.

- _____ 1. a looping fly ball
- _____ 2. with two outs in the inning
- _____ 3. hanging out of the window
- _____ 4. barely making ends meet
- _____ 5. a piece of pie with coffee
- _____ 6. drove in two runs
- _____ 7. worst loss of the season
- _____ 8. sliding into third



Context Clues: Using the Words You Know to Understand the Words You Don't

Context means “setting” or “environment.” Sentences and paragraphs are the *setting*, or *context*, of words. We use context to help us understand words. You are probably quite an expert in the process of identifying meanings from context clues—you just may not realize it.

We use context clues to understand other things as well. When you meet new people, you immediately start identifying them based on their family, clothes, accent, or home. Looking around their room you might use their books or belongings to figure out their personality. A person who has star charts on her walls and a telescope at her window may dream about traveling to the moon, and beyond!

This same process can be used to identify the meanings of unknown words. Look around (before and after) the unknown word at the other words in the sentence. Look at what the entire paragraph or essay is about. Use all of these context clues to determine the meaning of the unknown word.

There are several types of context clues that writers use to help readers understand unknown words. The chart on the following page lists and defines the six types of context clues and provides an example of each.

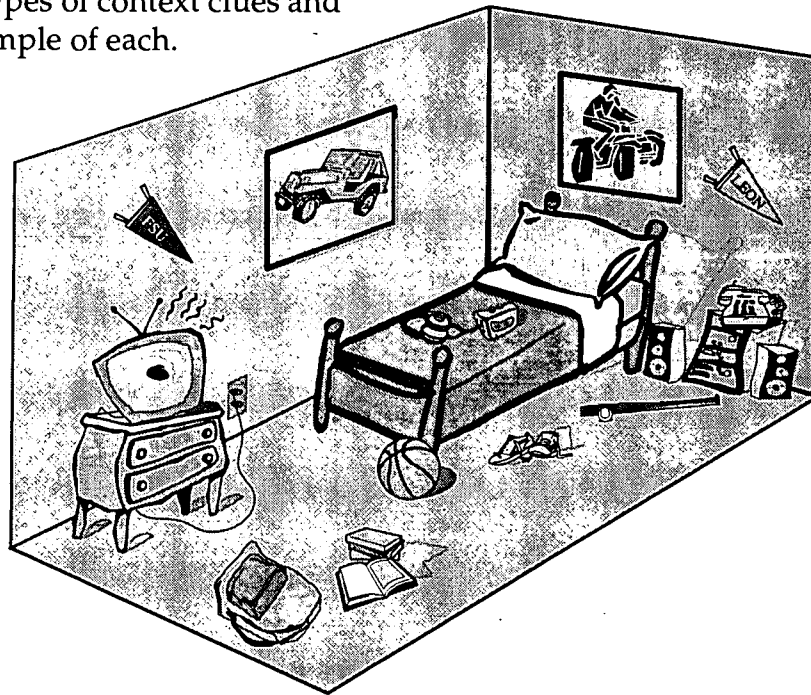



Examples of Context Clues

Type of Context Clue	Example (clues are bold; unknown word is underlined)
1. Synonyms mean the same thing as the unknown word.	<u>Fecund</u> , or fertile , lands are vanishing.
2. Examples show what the unknown word means.	The population of roaches in my cupboard was poisoned by the <u>extirpator</u> my husband had hired.
3. Direct Explanations define the unknown word.	<u>Euphobia</u> is the fear of good news.
4. Comparisons/Contrasts show how the unknown word is the same as or different from something familiar.	Comparison: <u>Buskers</u> , like all wandering musicians, depend on the public for their income. Contrast: Unlike a black fur coat, a <u>miniver</u> coat shows up the dirt.
5. Antonyms mean the opposite of the unknown word.	He was a <u>distingué</u> , not a peasant.
6. Physical Contexts place unknown word in a familiar physical setting.	Amongst the <u>bodkins</u> , pins, and patterns in the tailor's little shop lay all his half-finished suits and dresses.



Practice

Using the examples from the chart on the previous page, match the unknown word in the left-hand column with its correct meaning in the right-hand column. Write the correct letter on each line. Not all of the meanings will be used.

Word	Meaning
___ 1. fecund	A. protection
___ 2. extirpator	B. a needle
___ 3. euphoria	C. a nobleman
___ 4. busker	D. a wandering musician
___ 5. miniver	E. fertile
___ 6. distingué	F. fear of good news
___ 7. bodkin	G. white fur
	H. an exterminator
	I. an orbit



Practice

Write a short *definition* for the **bold** word. Use the **context clues** from each sentence to help you.

1. The **coruscating** shields and helmets were a consequence of constant polishing by the knight's servants.
Coruscating means: _____ .
2. Rude people are a nuisance; however, **felicitous** people make good companions.
Felicitous means: _____ .
3. Fred was **wan** after the surgery because he had lost a lot of blood.
Wan means: _____ .
4. Go ahead! **Venerate**, adore, and worship me. I like it.
Venerate means: _____ .
5. A good poet understands **cadence**, or rhythm, very well.
Cadence means: _____ .
6. I don't want Max to know I care, so I act **aloof** when I am with him.
Aloof means: _____ .
7. **Erudite** or ignorant, the people believed that the educational system had to be improved.
Erudite means: _____ .
8. She was **urbane** due to her excellent upbringing and varied social experiences.
Urbane means: _____ .
9. Most princesses in fairy tales are **winsome**; the witches are evil, ugly creatures.
Winsome means: _____ .
10. Marie doesn't like long, drawn-out plays; she prefers **brevity** in theater more than anything else.
Brevity means: _____ .



Practice

Find at least five unknown words in your textbooks that you can define by using context clues. Write down the sentence in which the unknown word appears, circle the word being defined, and underline key words that give clues to the meaning of the word. Then, write a definition of the circled word. Use only the context clues—do not refer to a dictionary. Record your information on the form below.

1. _____

Definition: _____

2. _____

Definition: _____

3. _____

Definition: _____

4. _____

Definition: _____

5. _____

Definition: _____



Application

Create a section for **vocabulary** in your notebook or portfolio that is labeled like the one below. As you read through your assignments each day, list words whose meanings you have been able to determine from context clues. Write a definition of each term using your own words. Check your meaning with a dictionary.

Daily Vocabulary	Date _____
Word: _____	
Contextual Definition: _____	
Dictionary Definition: _____	
Word: _____	
Contextual Definition: _____	
Dictionary Definition: _____	
Word: _____	
Contextual Definition: _____	
Dictionary Definition: _____	
Word: _____	
Contextual Definition: _____	
Dictionary Definition: _____	



Word Structure Clues: Unlocking the Meaning of a Word through Its Prefix, Suffix, and Base

Our vocabulary is a mishmash of Spanish, Sanskrit, Latin, Greek, and many other languages. Some of these languages are *living*, or still spoken, and some are *dead*, or no longer spoken. Every day new words are created by speakers while others fade out of use. We build words much like a child plays with blocks, adding a block here and dropping one there. Some of our word building is haphazard, and some is deliberate.

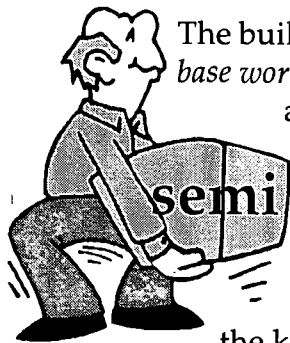

The building blocks of words are called *prefixes*, *suffixes*, and *base words*. A *prefix* is a word “block” added to the beginning of a word, such as the “un” in *undone*. Prefixes often change the meaning of the word from positive to negative, or negative to positive. A *suffix* is a word “block” added to the end of a word, such as the “ly” in *brightly*. Suffixes often tell you the kind of word (adverb, adjective, etc.)

it is and how it should be used in a sentence. A *base word*

(sometimes called a *root word*) is the main part of the word to which prefixes and suffixes can be added. For example, *annual* is a base word to which could be added a prefix (*semiannual*) or a suffix (*annually*) or both (*semiannually*).

The prefix *semi* means “half of”; the base word *annual* means “a year” and the suffix *ly* tells us it is used as an adverb. By knowing the meanings of prefixes, base words, and suffixes it is easy to unlock the meaning of unknown words.

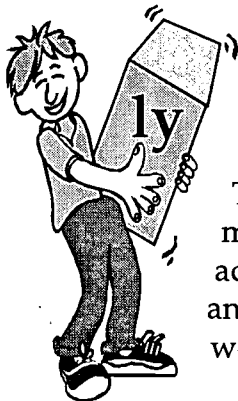
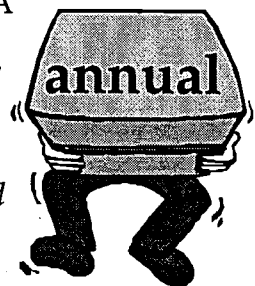

Many base words were formed from prefixes and suffixes long ago. For instance, *portfolio* comes from the Latin *portare*—“to carry out”—and *folium*—“a leaf.” If you know the building blocks of our language, unfamiliar vocabulary is easier to understand. Increasing your vocabulary is a worthy goal because you’ll be able to communicate more precisely. Instead of saying “I love you,” you could say, “I am besotted by your pulchritude!” Even if you’re not a linguistic romantic, you can use these skills to help you do better on tests! Study the tables of prefixes and suffixes on the next page.



Commonly Used Prefixes

Prefix	Meaning	Example	Prefix	Meaning	Example
a-	not	atypical	mono-	one	monorail
ante-	prior	antebellum	non-	not	nonsmoker
anti-	against	antisocial	penta-	five	pentagram
bi-	two or twice	bifocal	post-	after	posttest
dis-	opposite of; not	disinterested	pre-	before	prefab
ex-	out	exterior	re-	back; again	replace
fore-	before	forewarn	semi-	half; partly	semiconscious
il-	not	illegal	sub-	under	submarine
im-	not	improper	super-	above; beyond	supermarket
in-	inside; within; not	include	tele-	distant	telephone
inter-	between	intercontinent	trans-	across; beyond	transatlantic
intra-	within	intrastate	un-	not; opposite	unbelievable
mal-	bad, badly	malform	uni-	one	unicorn
mis-	wrong	misplace	ultra-	super	ultramodern

Commonly Used Suffixes

Suffix	Meaning	Example	Suffix	Meaning	Example
-able	able to be	trainable	-ist	one who does or uses	artist
-age	rate	dosage	-ity	quality	sanity
-al	action; process	rehearsal	-ive	performing an action	permissive
-ary	relating to	legendary	-ize	cause to be	computerize
-ate	cause to become	activate	-less	free from; without	worthless
-ed	past tense ending	talked	-like	like	childlike
-en	to make; made of	strengthen	-ly	like in manner or nature	motherly
-ence	state or quality of	obedience	-ment	result; action	wonderment
-er	one who; more	teacher	-ness	condition of	happiness
-est	surpassing all others	loveliest	-or	one who	actor
-fold	multiplied by	bifold	-ous	full of	famous
-ful	full of	beautiful	-s	more than one	cars
-hood	condition or state of	childhood	-ship	state of or condition of	internship
-ic	in the manner of	realistic	-tion	action or state	attention
-ing	action or process	skating	-ward	in the direction of	westward
-ish	somewhat like	sluggish	-y	like; full of	sunny



Practice

Write the **base word**, or **root word**, of the words below on each line. Some words have both prefixes and suffixes.

1. carries _____
2. responsive _____
3. intellectually _____
4. interchangeable _____
5. antinuclear _____
6. civilization _____
7. ultrasonic _____
8. atmospheric _____
9. unconditionally _____
10. realization _____
11. disinherit _____
12. telecommunications _____
13. vocalization _____
14. senseless _____
15. organization _____
16. repossess _____
17. childhood _____
18. accidentally _____
19. religiously _____
20. difficulty _____



Practice

Write the meaning of each of the **prefixes** below.

1. ante (as in anteroom): _____
2. anti (as in antifreeze): _____
3. bi (as in bicycle): _____
4. dis (as in disagree): _____
5. trans (as in transfer): _____
6. ex (as in export): _____
7. im (as in impossible): _____
8. in (as in inconsistent): _____
9. inter (as in intercom): _____
10. mis (as in misspell): _____
11. pre (as in prepay): _____
12. post (as in posttest): _____
13. sub (as in submarine): _____
14. super (as in superman): _____
15. un (as in unopened): _____
16. uni (as in unicycle): _____
17. penta (as in pentagon): _____
18. re (as in return): _____
19. mis (as in mistake): _____
20. re (as in redo): _____



Practice

To each base word below, add a suffix that fits the meaning given. Write each new word on the line.

Root Word	+	Suffix	Meaning	=	New Word
1. small	+	_____	most small	=	_____
2. thought	+	_____	without thought	=	_____
3. entice	+	_____	result	=	_____
4. care	+	_____	without care	=	_____
5. thank	+	_____	full of thanks	=	_____
6. willing	+	_____	condition of	=	_____
7. short	+	_____	most short	=	_____
8. hope	+	_____	without hope	=	_____
9. change	+	_____	able to be	=	_____
10. six	+	_____	multiplied by	=	_____
11. motor	+	_____	one who motors	=	_____
12. color	+	_____	cause to be	=	_____
13. nice	+	_____	in a nice way	=	_____
14. hard	+	_____	to make	=	_____
15. digit	+	_____	cause to be	=	_____



Practice

Given the **base word**, add the appropriate **suffixes**, and fill in the blanks with the correct forms of the base word.

- music** He found that he was _____ inclined after taking part in a _____. He hoped to become a _____ when he graduated from high school.
- interest** John found himself more _____ than most of his friends. John could speak _____ about things and could make me _____ in them.
- friend** Sally introduced her _____ to us. Myra was especially _____, and we were impressed with her _____.
- farm** We are finding fewer and fewer _____ as more and more people move into our cities.
- wise** The _____ that he spoke made us think about how much _____ he was than we were.



6. **post** A new _____ rate was
_____ by the _____
service.
7. **sum** _____ the story in your
_____ ; include only pertinent
information.
8. **invest** The _____ his
money and then made a lot of money from his
_____ .
9. **critic** Ms. Burns reviewed the play quite _____ .
All the other _____ thought her
_____ was a bit severe.
10. **west** The _____ movie was the story of a
_____ trek into the wilderness. The
movie made it seem that _____ winds
welcomed the pioneers.



Application

Each week, choose a special **prefix, suffix, or base word**. As you read through the assignments for your classes, make a list of words containing the word part that you have chosen. Write a **definition** for each word by using your knowledge of the meaning of the word part and any **context clues** that are provided. Check your definition with a dictionary.

Word Part		Week Ending	
Words	Context Clues	Definitions	
1. _____	1. _____ _____ _____	1. _____ _____ _____	
2. _____	2. _____ _____ _____	2. _____ _____ _____	
3. _____	3. _____ _____ _____	3. _____ _____ _____	
4. _____	4. _____ _____ _____	4. _____ _____ _____	
5. _____	5. _____ _____ _____	5. _____ _____ _____	



Precise Language: Using Specific Words to Convey Exact Images and Feelings

One way that a writer creates a precise image in a reader's mind is by using specific rather than general words. Look at the following examples.

Juanita noticed the dog sitting on the curb.

Juanita noticed the mongrel sitting on the curb.

Each person who reads the first sentence will create his or her own image about what the dog looks like. This image is often based on what we have directly experienced. For example, if you have always owned a large black dog, then you will probably imagine that a large black dog is sitting on the curb.

In the second sentence, the writer has changed the general word *dog* to the specific word *mongrel*. The word *mongrel* means "an individual resulting from the

interbreeding of diverse breeds." Seeing the word *mongrel* might make the reader think of a dog that is a mixed breed, mangy, and homeless. Using a more specific word forces the reader to see the same thing the writer sees, and feel the same way the writer feels about the subject.

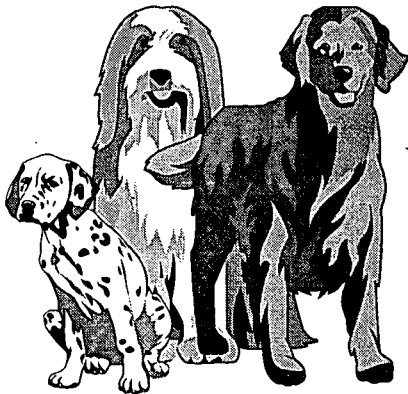
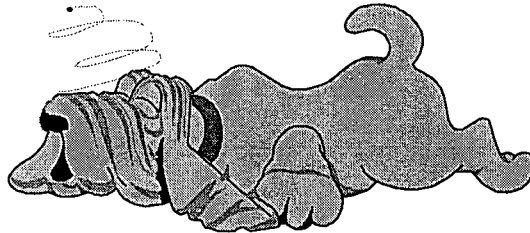

How would the meaning have changed if the writer had used the word *puppy*, *pooch*, or *hound*? Each of these synonyms for *dog* would create a different mental image in the reader. Writers should select their words carefully because many words have **connotations**: meanings that come from the emotions or ideas readers associate with particular words.



Practice

Read each of the following sentences. Write **F** if the underlined word has a **favorable** connotation and **U** if the underlined word has an **unfavorable** connotation.

- ___ 1. Melissa glared at her test score.
- ___ 2. Melissa beamed at her test score.
- ___ 3. Martin snickered at Melissa's painting.
- ___ 4. Martin admired Melissa's painting.

Each of the sentences below has a **general** word or phrase in bold. Write two specific **synonyms** for each general word or phrase.

5. The **house** sat on the corner of the treelined street.

Specific synonyms:

6. Arlo wished he hadn't **spoken**.

Specific synonyms:

7. The **football player** caught the ball.

Specific synonyms:

8. Terry **went** from one place to the next.

Specific synonyms:



Application

Write two **specific words** for each of the following **general words**—one with a *favorable* connotation and one with an *unfavorable* connotation.

General Words

Favorable

Unfavorable

1. cold	_____	_____
2. car	_____	_____
3. eat	_____	_____
4. walk	_____	_____
5. talk	_____	_____
6. clothing	_____	_____
7. man	_____	_____
8. food	_____	_____
9. shelter	_____	_____
10. shine	_____	_____
11. touch	_____	_____
12. brave	_____	_____
13. winner	_____	_____
14. good	_____	_____
15. fell	_____	_____



The Main Idea: Getting the Big Point

Before you can respond critically to what you are reading, you need to know the **main idea** of the material. The *main idea* is the most important idea of the reading selection. As you search for the main idea, consider the following four points:

1. the purpose of the author
2. key words which signal important ideas (*the best, most important, in conclusion, etc.*)
3. the opening and closing sentences of a paragraph, and the opening and closing paragraphs of an essay or story
4. the idea to which all the examples relate

Help yourself understand what you are reading by asking yourself the following questions:

- **Who** is the material primarily about?
- **What** is the material primarily about?
- **Where** do the events in the material take place?
- **When** do the events in the material take place?
- **Which** ideas, events, or situations in the material are crucial?





Sometimes the answers to the 5 W's (*Who? What? Where? When? Which?*) are not given directly, as in the following passage:

The sun shone brightly over the snowcapped peaks. Hikers had already started down the trail to the lake at the bottom of the valley. Allen didn't notice them. He sat quietly on a large boulder, his shoulders slumped and his head in his hands.

The answers to the 5 W's are not directly stated in this passage. However, we do know that the story takes place in the morning because the sun is shining and the hikers have left early. We know that Allen is preoccupied because he doesn't notice the hikers. We know he is either sad or in deep thought because he is sitting with "his head in his hands" and "his shoulders slumped." We also know this story takes place in the mountains because it mentions "snowcapped peaks." Although we need to do a little detective work, we can find the answers to the 5 W's by using the details or clues in this passage.

By using the indirect clues of the passage above we can answer the 5 W's.

- **Who** is the material about? *Allen*
- **What** is the material about? *a man sitting on a boulder thinking*
- **Where** does the passage take place? *the mountains*
- **When** does the passage take place? *midday*
- **Which** details are crucial to the material? *Allen doesn't notice his surroundings even though he is surrounded by beautiful scenery and other people.*

Remember: Use direct and indirect clues to help you understand what you are reading.



Practice

Before you read the following cartoon, familiarize yourself with the questions below. Then read the cartoon and answer the questions that follow.

ESSAYVILLE HIGH

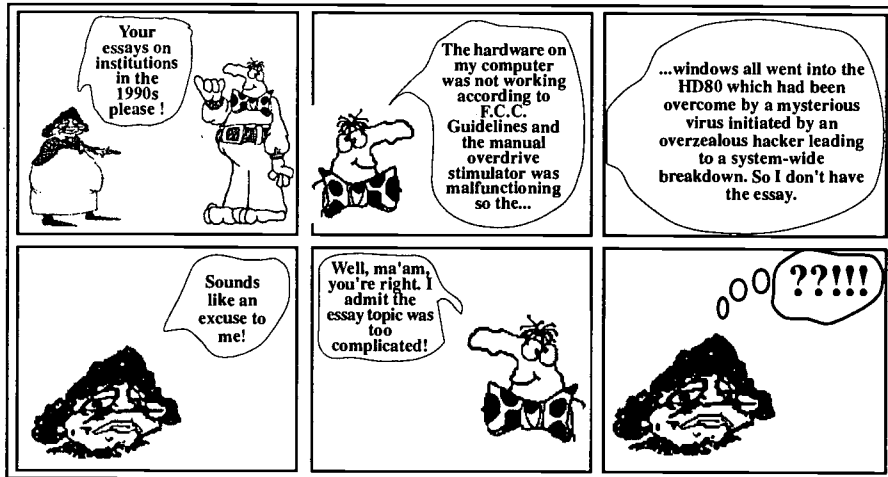

1. Who is the cartoon about? _____
2. What is the cartoon about? _____
3. Where does the cartoon take place? _____
4. When does the cartoon take place? _____
5. Which ideas are crucial to the cartoon? _____

6. How do the ideas in the cartoon connect to one another? _____

7. What is the main idea of the cartoon? _____



Literal and Figurative Language: Language That Points and Language That Paints

Authors use different kinds of language to give meaning to what they have written. The kind of language they use depends on the purpose for their writing. Writers use **literal language** if the purpose is to give directions or explanations. Writers use **figurative language** if the purpose is to help the readers "see" or "feel" what they are writing.

Literal language uses words for their exact, direct meaning. You will find a literal meaning if you look in the dictionary for a definition of a word. Literal language is used in material that is written to give information, directions, or explanations.

Figurative language uses words in such a way that the reader sees something special or feels a particular way. You will find figurative language in cartoons, poetry, tall tales, and other literature. Figurative language, or figures of speech, make ideas vivid for your readers.

Notice the different meanings for the words *red* and *push* in the following two sentences:

He knew how to push in the red lever.

He knew how to push her buttons and make her see red.

The first sentence uses literal language. The word *push* means "to press against," and the word *red* means a color. This sentence means exactly what it says.

The second sentence uses figurative language. The phrase *push her buttons* does not mean "to physically push buttons on this girl." Rather, it means "to make her upset." The word *red* does not mean "the color red." The girl will not see the color red when her buttons are pushed; instead, she will become upset and angry.

Figurative language includes special figures of speech. These include **similes**, **metaphors**, **personification**, and **onomatopoeia**. These figures of speech help readers to see, feel, and experience more exactly what the writer wants them to see, feel, and experience.



Similes and Methaphors: Making Comparisons

Similes and *metaphors* are comparisons. Notice the strong images created by the following simile and metaphor.

A *simile* uses the word *like* or *as* to make a comparison

Simile: “The black stove, stoked with coal and firewood, glows like a lighted pumpkin.”—Truman Capote, “A Christmas Memory”

Truman Capote uses “like” to compare the *stove* to a *jack-o-lantern*.

A *metaphor* implies a comparison without using such words.

Metaphor: “Morning is a new sheet of paper for you to write on.”—Eve Merriam, “Metaphor”

Eve Merriam implies a comparison—without using “as” or “like”—between a *new day* and a *clean sheet of paper*.

Personification: Adding Life to the Lifeless

Personification gives human qualities to lifeless objects or ideas.

Personification: The sun smiled on the children as they played.

The sun cannot smile. However, the reader understands that the writer is indicating that the sky was filled with pleasant sunshine—not too hot or too bright. Personification allows the reader to see ideas and objects in new ways.

Onomatopoeia: Using Words for Their Sounds

Onomatopoeia appeals to the reader’s imagination by using words that sound like their meanings. Some examples of onomatopoeia are *ooze*, *slurp*, *thud*, *splash*, and *sizzle*.

Onomatopoeia: The wind and rain whooshed through the open window.

The sound of the word *whooshed* is similar to the sound of the wind and rain coming through the window.



Practice

Identify the **figure of speech** in each sentence by writing **S** if it is a simile, **M** if it is a metaphor, **P** if it is personification, or **O** if it is onomatopoeia.

- _____ 1. "The Commander's voice was like thin ice breaking."
—James Thurber
- _____ 2. "The room spoke to us of former days."
—William Shakespeare
- _____ 3. The snow crunched under our feet.
- _____ 4. The sky is full of tears.
- _____ 5. The beehive of humanity released a swarm of people to begin their daily chores.
- _____ 6. Her smile was like the sun breaking through on a cloudy day.
- _____ 7. After the accident, I was haunted by the screech of tires on dry pavement.
- _____ 8. The blank TV screen stared at me with unseeing eyes.
- _____ 9. "But death is a slave's freedom."
—Nikki Giovanni
- _____ 10. To love is to make a three-point shot.



Application





Prepare a section of your portfolio or journal as a **vocabulary matrix**. Set up your matrix like the chart shown below. As you encounter words with figurative and/or technical meanings in your various reading assignments, enter them in your matrix. Then provide the definitions that are appropriate—a literal definition that you have obtained from context, word structure, or a dictionary; a figurative meaning; and a specialized meaning—technical or idiomatic.

Vocabulary Matrix			
Vocabulary Word	Literal Meaning	Figurative Meaning	Specialized Meaning
<i>frosting</i>	<i>sweet topping on a cake</i>	<i>the last or best as in "The frosting on the cake was when I won the contest."</i>	<i>in a beauty parlor, frosting is a process for putting blonde streaks in your hair</i>

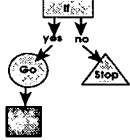
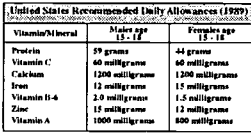
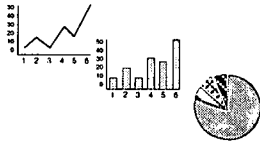

Understanding Visual References: Reading the Guides

Visual references include all the following: directories, diagrams, tables, graphs, schedules, pictures, maps, and signs. These kinds of references may be found not only in the sources of information described in this unit but also in computer programs, in manuals, in advertising, and along roads. They condense information so that it can be read easily and quickly. Visual references are often used to summarize and to supplement written information. Study the following table, which explains visual references.

Visual References			
Reference	Symbol	Concept	Location
Directory		<ul style="list-style-type: none"> a plan or layout of a building or buildings a list of phone numbers in alphabetical and regional order 	Department stores Archeological sites Supermarkets Malls Historical buildings Museums
Diagram		<ul style="list-style-type: none"> a picture showing a process; parts of a whole; how something works 	Instruction books Manuals Science books
Table		<ul style="list-style-type: none"> a chart giving information in column or list form 	Magazines Business reports Maps
Graph		<ul style="list-style-type: none"> a symbolic diagram representing a comparison of quantities 	Climate reports Medical books Business reports Classrooms
Schedule		<ul style="list-style-type: none"> a table which gives information on when and where something takes place 	Bus & train stations Airports TV guides Movie guides Schools
Map		<ul style="list-style-type: none"> a representation in outline of a geographical area 	Brochures Guide books History books
Sign		<ul style="list-style-type: none"> a symbol used to represent something instead of, or with, words 	Roads Hospitals Appliances Product labels Vehicles Mathematics books



Practice

Imagine that you are doing a research report about two important archeological sites near your school, a Native American burial ground and a Spanish mission. Consult the phone directory below to locate local experts on these sites and a museum specializing in early Florida history. Answer the questions that follow.

49 ARCHEOLOGISTS-ARCHIVES	
M	
Museum of Early Florida History	
111 N. 2nd St.....	636-9811
Musgrove, I. Altha Hwy. 261.....	636-2471
N	
National Archeology Foundation	
111 W. 1st St.....	1-800-OLD-SITE
Nedley, W.J. 2004 Elk St.....	423-9976
Neel, Howard 112 Oak Ln.....	679-3410
O	
Old Towne Indian Artifacts	
49 Market St.....	653-0290
Owens Nursing Home 101 2nd St.....	698-3414

1. What is located at the number 636-9811? _____

2. What does Old Towne Indian Artifacts specialize in? _____
3. A member of the Seminole tribe lives at the Owens Nursing Home and can help you understand burial mounds. What is his number?

4. Where is the *Owens Nursing Home* located?

5. How many entries are found under *O*? _____



Practice

Study the maps and the directory below. Complete the statements on the following pages by circling the letter of the correct answer.

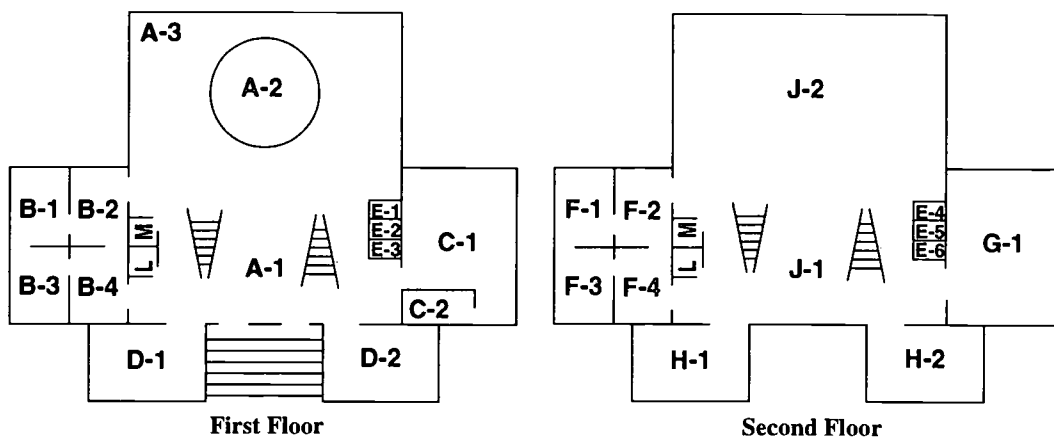

Museum of Early Florida History Directory

APALACHEE TRIBE

Costumes	B-1
Beadwork	B-2
Weaponry	B-3
Food	B-4

BURIAL MOUNDS

Ceremonies	D-1
Artifacts	D-2

CREEK TRIBE

Costumes	C-1
Pottery	C-2

EDUCATION DEPT.

All Areas	G-1
-----------	-----

ESCALATORS

First Floor	E1-3
Second Floor	E4-6

EXHIBITS

Current Exhibits	
Central Display	A-2
Display Hall	A-3
Travelling Exhibits	J-2

INFORMATION

Office	A-1
--------	-----

RESTROOMS

First Floor	
Ladies	L
Men	M
Second Floor	
Ladies	L
Men	M

SEMINOLE TRIBE

Costumes	H-1
Tribal Politics Today	H-2

SPANISH SETTLERS

Friend of Foe	F-1
Missions	F-2
Sites	F-3
Trade	F-4



1. The Museum has _____ .
 - a. one floor
 - b. two floors
 - c. three floors
 - d. four floors

2. Information can be found _____ .
 - a. on the first floor
 - b. on the second floor
 - c. next to the education department
 - d. beyond the Seminole exhibits

3. To find information on burial mound artifacts, look in section _____ .
 - a. H-1
 - b. H-2
 - c. D-1
 - d. D-2

4. Restrooms are located _____ .
 - a. on the first floor
 - b. on the second floor
 - c. on the first and second floors
 - d. on the third floor

5. Information on Spanish Missions can be found next to _____ .
 - a. Seminole Tribal Politics Today
 - b. Creek pottery display
 - c. Spanish Settlers—Sites
 - d. Spanish Settlers—Friend or Foe

6. The exhibitions on the Creek Tribe are found _____ .
 - a. next to the traveling exhibitions
 - b. next to the tribal politics display
 - c. next to the escalators
 - d. all of the above



7. Food of the Apalachees is found _____ .
 - a. next to the ceremonies of burial mounds
 - b. on the second floor
 - c. next to costumes of the Apalachees
 - d. next to the traveling exhibitions

8. There are _____ escalators.
 - a. three
 - b. six
 - c. nine
 - d. two

9. In room F-2 you would find _____ .
 - a. information about Spanish missions
 - b. artifacts from burial mounds
 - c. traveling exhibits
 - d. Education Department

10. _____ contain information you would use for a project titled "A Comparison of Native American Costumes."
 - a. Rooms A-3 and B-1
 - b. Rooms H-1, H-2, F-4, and G-1
 - c. Rooms B-1, C-1, and H-1
 - d. Rooms B-1, C-1, and H-2



Practice

Study the following schedule and then answer the questions that follow.

	MON	TUES	WED	THUR	FRI	SAT	SUN
8:00 AM to *5:00 PM	Day Rate Period Full Rate						
5:00 PM to *11:00 PM	Evening Rate Period 35% Discount						
11:00 PM to *8:00 AM	Night & Weekend Rate Period 60% Discount						

* to but not including

1. Which rate will you pay to make a call during school hours or between 8:30 AM and 3:30 PM?

2. In order to receive a 60 percent discount, should you make a call on Saturday or Sunday evening between 5:00 PM and 11:00 PM?

3. What is the rate at 8:00 AM on Friday? _____
4. Your bill states that you received a 35 percent discount for a phone call you placed on Sunday. Between what hours did you place this call?

5. Which rate will you pay for a call at 7:00 PM on Wednesday?



Practice

In order to calculate the distances between various Florida cities, consult the mileage table below. Circle the correct answer to the questions that follow using this table.

Remember: Tables, graphs, and schedules require you to read down a column and across a row. The point at which the column and row intersect, or meet, is the box that contains the information you are searching for. In the mileage table below, choose one of the cities along the column and the other city along the row. Then find the box in which the respective column and row meet. The number in the box is the distance in miles between the two cities.

Mileage Table

	Daytona Beach	Ft. Lauderdale	Gainesville	Jacksonville	Key West	Orlando	Panama City
Daytona Beach	●	236	98	96	419	54	338
Ft. Lauderdale	236	●	314	332	185	209	559
Gainesville	98	314	●	70	497	114	250
Jacksonville	96	332	70	●	515	145	270
Key West	419	185	497	515	●	392	742
Orlando	54	209	114	145	392	●	385
Panama City	338	559	250	270	742	385	●

Distance in Miles between Cities



1. Daytona Beach to Jacksonville is _____ .
 - a. 96 miles
 - b. 70 miles
 - c. 236 miles
 - d. 338 miles

2. There are 70 miles between Jacksonville and _____ .
 - a. Fort Lauderdale
 - b. Daytona Beach
 - c. Key West
 - d. Gainesville

3. It is further between Orlando and Panama City than between _____ .
 - a. Gainesville and Key West
 - b. Fort Lauderdale and Panama City
 - c. Daytona Beach and Panama City
 - d. Daytona Beach and Key West

4. The cities that are closest to each other are _____ .
 - a. Jacksonville and Gainesville
 - b. Orlando and Daytona Beach
 - c. Orlando and Key West
 - d. Gainesville and Daytona Beach

5. Key West is closest to _____ .
 - a. Orlando
 - b. Daytona Beach
 - c. Fort Lauderdale
 - d. Panama City



Visual Messages: Reading Signs, Graphs, and Diagrams

Traditionally, certain colors symbolize particular emotions or messages. It is quite easy to guess at the origins of these symbols. For example, red is usually used to warn people. Fire and blood are both red. Green is used to indicate going forward or life. Plants are green. Different cultures may give different symbolic meaning to colors. In India, white is used not for marriage but for mourning. Red is used for marriage! The more simple a *sign* is, the easier and quicker it is to understand. This is important because sometimes we only have a moment to read a sign before we need to heed its message. Also, people from other cultures or who speak another language would be better able to comprehend a well-designed sign. A sign that said

Excuse me, but it is **VITALLY**
IMPORTANT that you **STOP** in a
hurry!

is not nearly as effective as

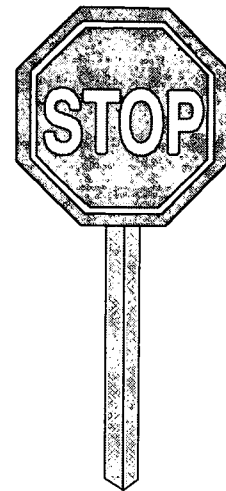

By the time anyone could have read the first sign, he would have already whizzed by and into oncoming traffic.

Like signs, diagrams and graphs should present information more clearly than words alone. Otherwise, why bother to create them?



Practice

Match the sign in the left-hand column to its message in the right-hand column.

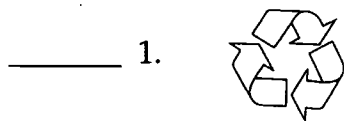

A. Rewind

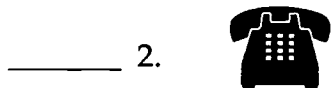

B. Temperature

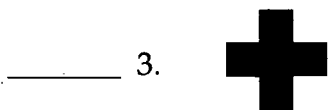

C. Barber Shop

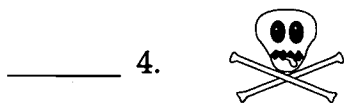

D. Recycle

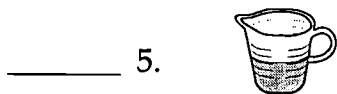

E. Call if you have questions about our product.

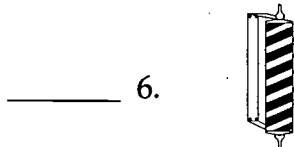

F. Forbidden

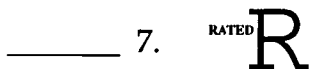

G. First Aid

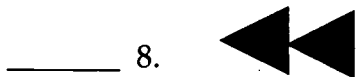

H. one-half cup

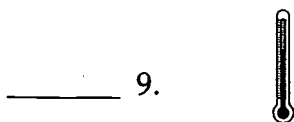

I. Warning! Poison

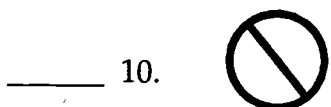

J. Restricted movie



Practice

Imagine that during the course of your research on Florida's people, you dig up two different sources of information. Study and compare the **pie graph** and **bar graph** below; then circle the best answer to the questions that follow.

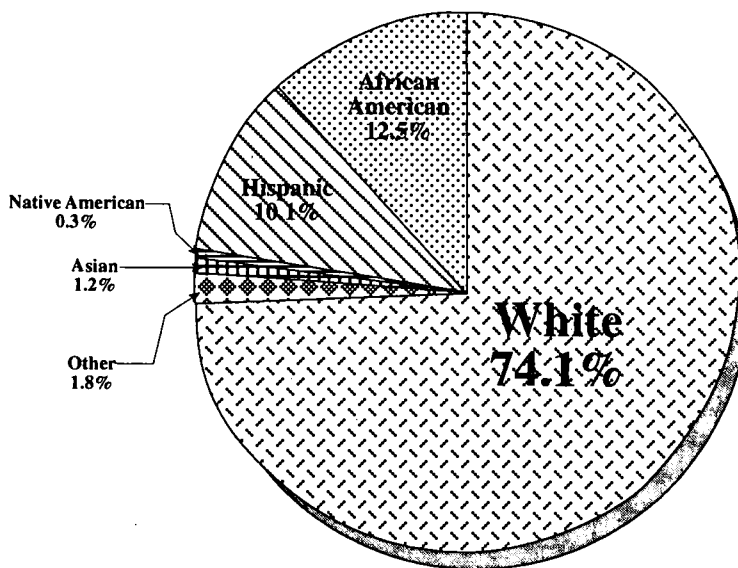

Pie Graph

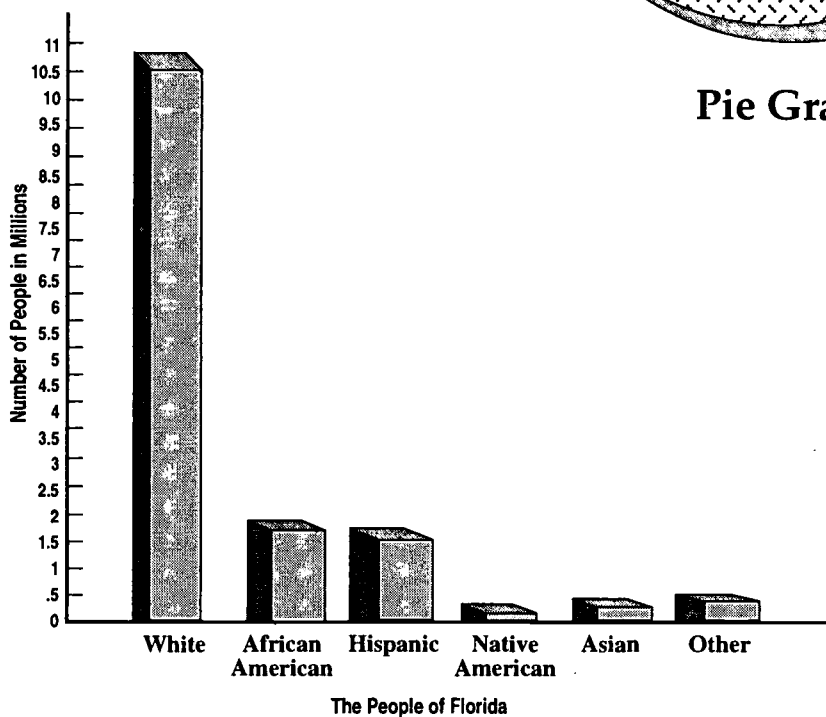

Bar Graph



1. _____ of Florida's population is Asian.
 - a. 1.8 percent
 - b. 0.3 percent
 - c. 1.2 percent
 - d. 12 percent

2. You could calculate how many Asians live in Florida by using _____ .
 - a. both of the graphs
 - b. only the pie graph
 - c. only the bar graph
 - d. neither of the graphs

3. Florida's white population is _____ .
 - a. 74.1 percent or approximately 10,000
 - b. 7.41 percent or approximately 105,000
 - c. 7.41 percent or approximately 10,500,000
 - d. 74.1 percent or approximately 10,500,000

4. There are more whites in Florida than _____ .
 - a. Hispanics
 - b. Asian
 - c. African Americans
 - d. all of the above

5. According to the graphs, the original inhabitants of Florida, Native Americans, _____ .
 - a. are the smallest ethnic group in Florida
 - b. outnumber Asians
 - c. are equal in number to the group labeled *other*
 - d. are 3 percent of Florida's population

6. The Hispanic population of Florida is _____ .
 - a. larger than the African-American population
 - b. larger than the Asian population
 - c. smaller than the population labeled *other*
 - d. smaller than the Native-American population



7. Numbers on the bar graph represent _____ .
 - a. hundreds
 - b. thousands
 - c. millions
 - d. billions

8. The total population of _____ is fewer than 1,000,000.
 - a. Native American, African American, and Other
 - b. Native American, Hispanic, and Other
 - c. Native American, Asian, and Hispanic
 - d. Native American, Other, and Asian

9. _____ each make up more than 10 percent of Florida's population.
 - a. Whites, African Americans, Asians
 - b. Whites, Hispanics, African Americans
 - c. Whites, Other, Hispanics
 - d. Whites, Other, African Americans

10. The combined populations of Native Americans, Other, African Americans, Asians, and Hispanics _____ .
 - a. outnumber the white population
 - b. equal the number of the white population
 - c. equal fewer than 10 million people
 - d. equal 50 percent of Floridians



Practice

To illustrate a project you are working on, you decide to use photographs. To learn how to use a camera, your teacher assigns you a camera with the **diagram** below. Study the diagram; then answer the questions that follow.

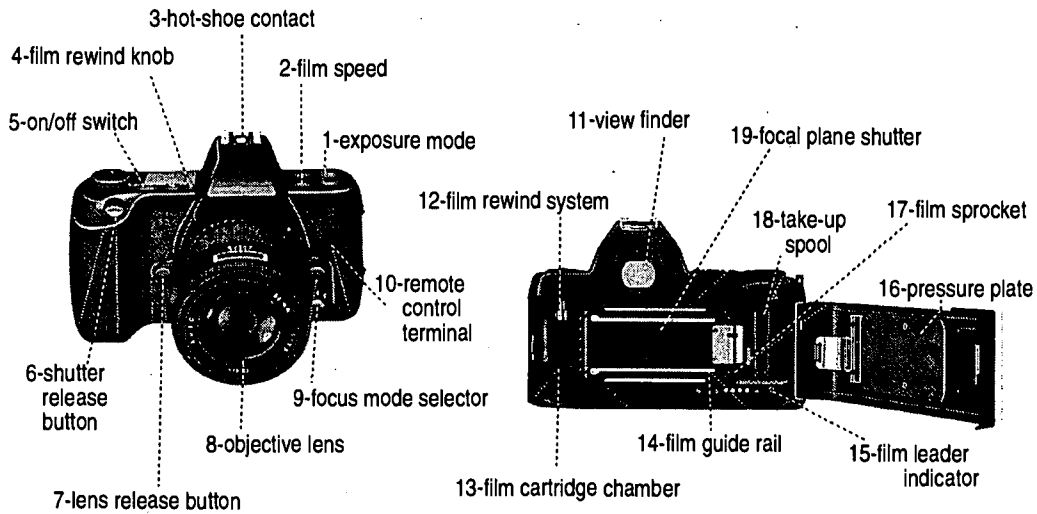

- 1- Sets exposure to manual or automatic adjust
- 2- Programs the camera's light exposure meter to the speed of the film purchased
- 3- Contact for operation of flash attachment
- 4- Button that starts the auto-rewind system
- 5- Power button
- 6- Opens the shutter to expose picture to the film
- 7- Release button for changing lenses
- 8- The normal camera lens that has one focal length (50mm) and the widest aperture or opening ($f 1.4$)
- 9- Sets focus to manual or automatic mode
- 10- Connection to allow for accessory which operates camera from a remote device
- 11- Window for viewing the picture before releasing the shutter
- 12- The mechanism that turns to rewind the film
- 13- The compartment that holds the film
- 14- A centering guide for the film
- 15- Indicates that the leader of the film is connected and ready to be advanced
- 16- Presses the film to the focal plane shutter
- 17- A notched wheel that catches the holes in the sides of the film
- 18- The mechanism that turns to advance the film
- 19- A cover or curtain to prevent film exposure to light when changing lenses



1. What is the function of the *hot-shoe contact*?

2. Where do you put the film? _____

3. What is the function of the *focal plane shutter*? _____

4. How would you rewind film in this camera? _____

5. What helps you to frame your picture? _____

6. What is an *objective lens*? _____

7. How can you be sure that your film will advance and go through the camera?

8. What does the *remote control terminal* allow you to do?



Application

*Find one example of a **diagram, graph, or statistical illustration** that you feel really helped you understand something in one of your classes. Write a **paragraph** that explains why this particular visual reference was so helpful.*



Finding Information: Identifying the Right Source

Historians are calling this the *Information Age*. We are flooded with information from many sources: computers, television, cable, radio, video, faxes, and good old books. From the time we get up to the time we nod off we'll have read hundreds or thousands of words and ignored many more.



Words and messages are a constant part of our daily lives. They assault, seduce, and sing to us from road signs, computers, packages of foods, phone books, calendars, and schedules. They tell us what is good for us, what we should buy, how we should believe, and what we should know. It is important to be able to sift through all the available information, understand what it is saying, and select the information that is needed when it is needed. Those who shy away from information, or who are unable to discriminate between what is useful and what is not, will be less desirable job applicants, vulnerable consumers, and easily influenced citizens.

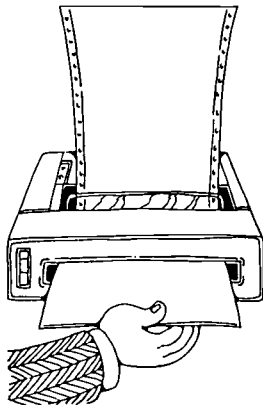
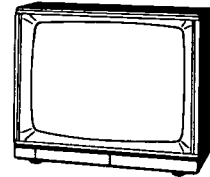

The amount of information available to us grows every day. Consider the amount of information available to you compared to that available to your great-great grandparents. Since the time of your ancestors, humankind has gone to the moon, invented the computer, and accessed the world via the World Wide Web. For every new idea, product, or process there is a massive amount of information created. One of the most important skills you can acquire is to learn how to find, understand, and use information.



The chart below includes a variety of resources and the kinds of information found in each.

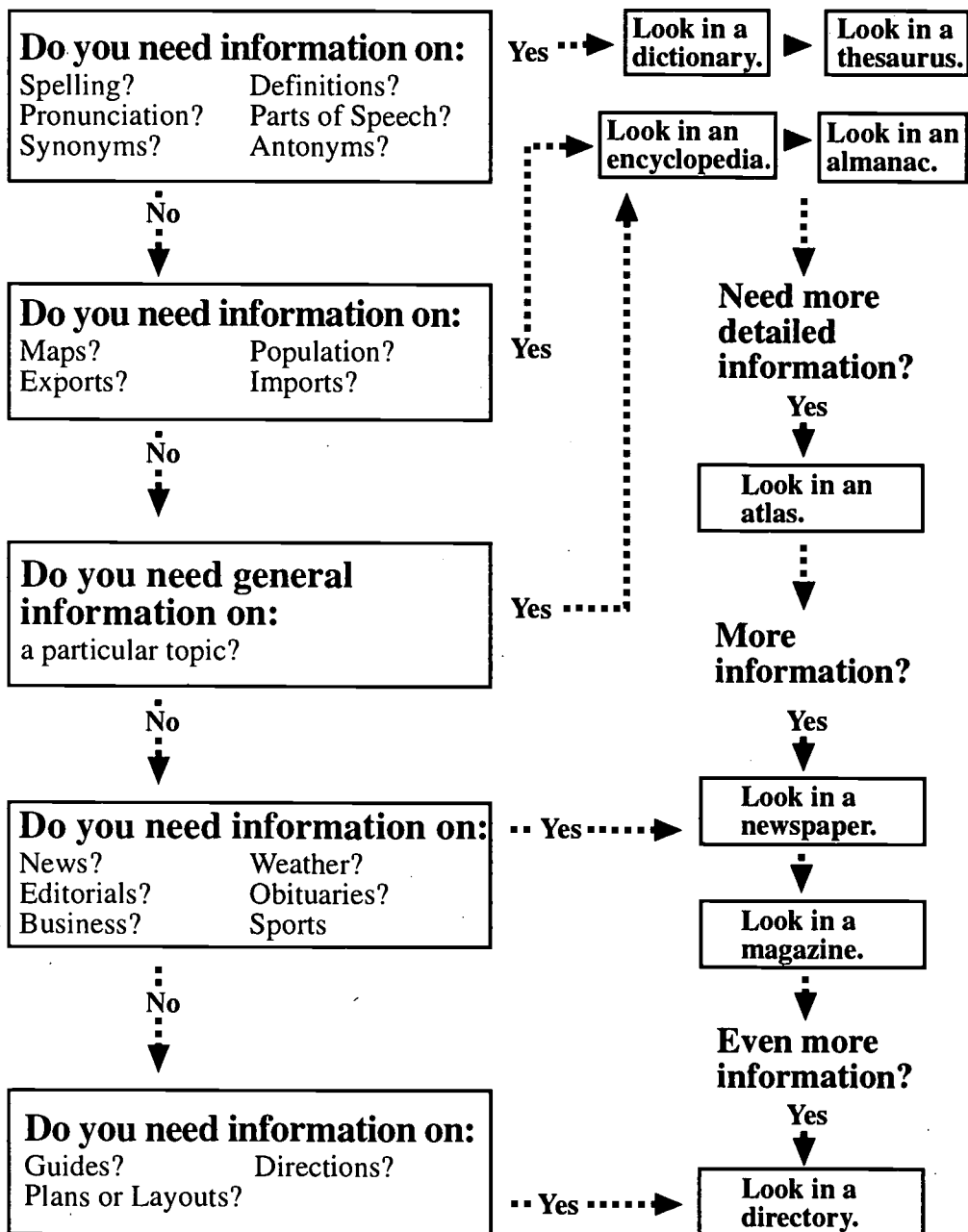



Practice

Use the chart on the previous page to answer the question below.

- _____ 1. Which source should you consult for a general overview of Florida history?
- _____ 2. Which source should you consult for specific information on Florida's climate and for detailed maps?
- _____ 3. Where should you search for information on current Florida politics?
- _____ 4. Where should you look for the phone numbers of two senior citizens who helped build the Jacksonville-Miami railroad?
- _____ 5. Where should you look to check the spelling of words?
- _____ 6. Where should you look to find a list of synonyms for a word?
- _____ 7. Which source would you use to find a weather forecast?
- _____ 8. Where should you look to find out how to pronounce a word?
- _____ 9. Which source should you use to find the distance between two cities?
- _____ 10. Which source would you use to find a list of antonyms for a word?



The Index, Table of Contents, and Dictionary: Specific and Detailed Information

Once you have located appropriate sources of information, you obviously need to know how to locate specific information within them. Most books will contain an *index*, a table of contents, or both to help you. A *dictionary*, however, is organized alphabetically, and each entry follows a specific sequence of information.

An *index* is located at the end of a book. It gives an alphabetical listing of all subjects covered in the book and the page number(s) where the subject appears. An index may also appear on the front page of a newspaper.

A *table of contents* is located at the front of a book. It shows how the book is organized and gives page numbers of chapters and subtopics within those chapters.

Index	
A	E
Animals	Endangered species 6, 8, 12, 13, 45, 88
manatee, 6, 12, 45, 88	
mullet, 13	
panther, 8	
B	F
Birds, 11	Florida Rivers, 11
brown pelican, 10	wildlife 13, 17, 20
osprey, 20, 28	
C	G
Camping, 41	Geography, 97
clothing, 43	
equipment, 45, 87, 93	
D	C

Florida Wildlife	
Table of Contents	
Chapter 1	
Endangered Species by J. Schuller	5
Manatee	6
Panther	8
Brown Pelican	10
Chapter 2	
Wildlife on Florida Rivers by T. Chisholm	11
Mullet	13
Limpskins	17
Osprey	20
Chapter 3	
Pollution-A Silent Killer by T. Foster	21
DDT	25
Boats and Oil	30
Chapter 4	
An Environmental Hero by T. Sullivan	31
Audubon	35

Dictionary entries typically begin with the correct spelling, followed by the correct pronunciation. The history of a particular word can precede or follow the definition. The particular sequence varies from dictionary to dictionary, but all dictionaries are organized alphabetically.



Practice

Use the table of contents below to answer the following questions.

Florida Wildlife	
Table of Contents	
Chapter 1	
Endangered Species by J. Schuller	5
Manatee	6
Panther	8
Brown Pelican	10
Chapter 2	
Wildlife on Florida Rivers by T. Chisholm	11
Mullet	13
Limpkins	17
Osprey	20
Chapter 3	
Pollution—A Silent Killer by T. Foster	21
DDT	25
Boats and Oil	30
Chapter 4	
An Environmental Hero by T. Sullivan	31
Audubon	35
Chapter 5	
The Birder's Trip by A. Fielding	41
Clothing	43
Equipment	45

1. Which chapter is about wildlife on Florida rivers? _____
2. Who wrote the article titled "An Environmental Hero"?

3. On what page(s) would you find information on *limpkins*?

4. Under which heading does information on *boats* and *oil* appear?

5. What can be found on pages 31-40? _____
6. Which endangered species are included in Chapter 1?



Practice

Study the index below and decide whether the statement is correct or incorrect. Write **True** if the statement is correct. Write **False** if the statement is incorrect. (Numbers refer to the pages within a section, and letters refer to the section.)

Florida Times	
INDEX	Page
Business	2B
Capitol Report	1A
Classified	5B
Comics	3C
Editorials	15A
Local News	2A
Movies	4C
National News	4A
Sports	6C
Statewide News	3A
Television	8C
Weather	1A

- _____ 1. Page 1A will show weather conditions.
- _____ 2. Section C covers sports and business news.
- _____ 3. The *Capitol Report* appears in the same section as other news.
- _____ 4. Editorial opinions are located on page 15C.
- _____ 5. Section D lists jobs that are available.



Practice

After examining the section of an **index** below, circle the letter of the answer that best completes each statement below. Illustrations are indicated by an **i**.

INDEX

Agriculture

See also: Uses

Apalachicola River 6, 15, 93

See also: Rivers

Basins 54-66, 286

See also: Rivers

Cross-Florida Barge Canal 7, 104, 118, 119

Cypress

pond 93

prairies 93

See also: Wetlands

Development 6, 65, 72

Energy (U.S. Dept. of) 266

Everglades 7, 63-65, 94-95, 138*i*

1. Information on agriculture can be found _____ .
 - a. on page 6, 15, 93
 - b. under *Uses*
 - c. on page 6
 - d. under *Farming*
2. Information on cypress *cannot* be found _____ .
 - a. on page 93
 - b. under *Cypress prairies*
 - c. under *Wetlands*
 - d. under *See also: Rivers*



3. Page 266 contains information on _____ .
 - a. U.S. Department of Energy
 - b. Florida Department of Energy
 - c. energy sources
 - d. national energy policies

4. On page 138 there is _____ .
 - a. an essay on the Everglades
 - b. a description of the Everglades
 - c. an illustration of the Everglades
 - d. a story set in the Everglades

5. Under *Rivers*, you could find information on _____ .
 - a. basins and the Apalachicola River
 - b. basins and the Cross-Florida Barge Canal
 - c. the Chattahoochee River
 - d. the Apalachicola River and estuaries



Application

Find and use **resources** to answer the following questions.

1. What is the longest river on the continent of Asia? _____

Source of information: _____

2. What is the population of Florida? _____

Source of information: _____

3. What does the word *osculate* mean? _____

Source of information: _____

4. List three novels by writer John Steinbeck. Give the year each of these novels was published.

Source of information: _____

5. From what language is the word *assassin* derived?

Source of information: _____



6. Which football team won the Super Bowl in 1986?

Source of information: _____

7. Through which states does Interstate 81 pass? _____

Source of information: _____

8. For what sport is 1996 Olympian Michele Smith famous? _____

Source of information: _____

9. What is the phone number of your high school? _____

Source of information: _____

10. What television show is on Wednesdays at 9:00 PM on PBS?

Source of information: _____

11. What are three synonyms for *confuse*? _____

Source of information: _____

12. What is the longest chapter in your science book? _____

Source of information: _____

13. What is the zip code of your high school? _____

Source of information: _____



14. How many miles is it from Lakeland, Florida, to Orlando, Florida?

Source of information: _____

15. Who wrote the poem "Fog"?

Source of information: _____

16. What day of the week will April 1, 2010 be?

Source of information: _____

17. What was the temperature in San Francisco, California, yesterday?

Source of information: _____

18. What are three endangered species that are native to Florida?

Source of information: _____

19. Which chapter in *Tom Sawyer* is called "The Cat and the Painkiller"?

Source of information: _____

20. How many years are there in a millennium?

Source of information: _____



Responding to What You Read: Interacting with Material

Part of the reading process is responding to what you are reading. There are many ways you can respond to something you have read. You can make a list of important ideas, write a summary or abstract, write a paragraph or essay in response, draw a picture that illustrates a concept, or rewrite an ending to a story or play. In this section you will respond to what you are reading by summarizing information and evaluating the material.

Summarizing Information: Telling the Main Points

A *summary* is to a piece of writing what a skeleton is to a body. It outlines in brief the structure and central ideas of the writing. From a skeleton you could summarize the form and purpose of the body. From a summary you should be able to understand the content and purpose of a piece of writing. Being able to summarize well is a skill that will benefit you in your high school classes, in college, and in the work place.

A good summary can provide you with a useful easy-to-use source of information for essays, papers, test preparation, letters, and other documents you may need to write in your future jobs.

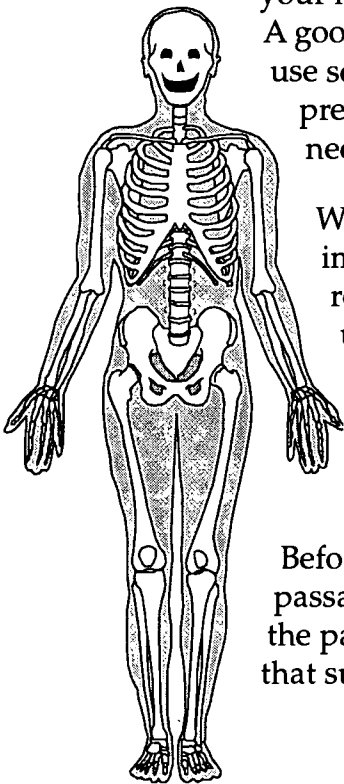

When you write a summary you will use two important skills: understanding what you read and reorganizing important information. Once you understand what you have read, recognize the main ideas and supporting details, and reorganize your information, you are ready to put the writing into your own words. A good summary is *not a list of quotations from the original material*.

Before you begin to write your summary, read the passage twice. Read it the first time to get an overview of the passage. Read it a second time to discover the details that support the main idea. Pay careful attention to



introductions, conclusions, topic sentences, subtitles, and specific details during the second reading.

During or after your second reading, take notes on essential information. (See Unit 2 for ideas on taking notes.) One way to recognize essential information is to see if the passage would make sense without it. If you removed the spine from a skeleton, the body would look very peculiar and probably collapse! If information is essential to a passage, the passage would not make sense without it. Information that may not be essential to a passage includes examples, anecdotes, stories, words in parentheses, and minor details. Your summary should be about one-quarter of the length of the original passage.

The last step in preparing a summary is to reread it and compare it to the original passage. Make sure you have not left out anything essential or have not added anything that was not there to start with.

Preparing a Summary

1. Record the title of the chapter or article and the author.
2. Record the name of the source containing your selection and the date it was published. This could be the name of a book, magazine, newspaper, movie, or other original source.
3. Preview the reading selection.
4. Read the selection to get an overview.
5. Reread the passage carefully for essential information. Write down any unfamiliar words, and use the dictionary or context clues to find out what they mean.
6. On a planning sheet, write down the following:
 - a) what you think the main idea of the selection might be;
 - b) the most important facts you learned from reading the selection. Record facts using fragments or phrases: *Do not copy complete sentences or paragraphs*. Set off each fact with a number, letter, or bullet.



7. Note the method used to present information: listing of facts, comparison or contrast, chronological order, illustration, cause and effect, and order of importance.
8. Use this information to write a summary of your selection. Make sure to turn your notes into complete sentences as you write.

The following chart lists some key words and phrases you should look for when you are reading and use when you are summarizing.

Examples of Key Words Indicating Key Points

A vital factor,

A central concern,

In conclusion,

Essentially,

A major reason,

Most importantly,

Because of,

In response to,



Practice

Read the newspaper article below. Use the form that follows to plan a **summary** of the article. Use your own paper to write a draft and final summary.

4D/Sunday, March 17, 1996

Tallahassee Democrat

Consistency is the hobgoblin of McGriff's career

The Atlanta Braves Slugger has put up big numbers so often that he's sometimes taken for granted.

**By Paul Newberry
THE ASSOCIATED PRESS
WEST PALM BEACH**

Let's see, what can the Atlanta Braves expect from Fred McGriff this season? Thirty homers? Sure. A hundred RBIs? Good chance. In fact, it's just about taken for granted. So is McGriff, which has kept him from getting the recognition such feats deserve.

"Generally, the guys who get all the attention in this league are the guys who are having really great years or the guys who are having years that aren't typical years," said pitcher Tom Glavine, himself a victim of the consistency syndrome.

"The typical Fred McGriff year is to hit .280, get 30 homers and drive in 100 runs," Glavine said. "He's not going to get attention for it because, let's face it, he does it every year.

Before last year's strike-shortened season, McGriff had hit between 31 and 37 homers for seven straight seasons -- despite playing with three different teams, in ballparks with wide-ranging long-ball difficulty. With fewer games in

1995, he managed only 27 homers, but it's worth noting he was on pace to hit 30 in a full 162 game season.

His RBI totals have hardly wavered over the past seven seasons. His career high was 106 with San Diego in 1991; his low mark during that time was 88 with Toronto in 1990.

Still, no one seems to mention McGriff in the same breath as the Bonds and Griffey's of the world.

"It's not a big deal to me," McGriff said. "One thing about it: If you're consistent, then it's kind of like people take you for granted. People just assume you're going to hit 30 homers and drive in 100 runs.



McGriff

"If you're consistent... people just assume you're going to hit 30 homers and drive in 100 runs."

But all of a sudden a guy comes out of the blue and hits 30 home runs and drives in 100 runs, then it's a big deal. Or the minute I don't hit 30 homers, then it's a story. It's just one of those things."

Even McGriff seems to have

adopted that line of thinking. Just listen to his assessment of the 27-homer, 93-RBI, .280-hitting season he had in Atlanta's World Series-winning 1995 season:

"I struggled a lot last year," McGriff said. "I didn't have my best year. I never got real consistent with my mechanics...I never really got going."

Part of the reason for McGriff's low recognition factor is beyond his control. He began his career with Toronto, where he usually batted seventh or eighth in the order and played in the shadows of All-Star outfielders Lloyd Moseby, George Bell and Jesse Barfield.

In 1991, he was traded to San Diego, where home games usually begin well after 10 p.m. on the East Coast. He had 2 1/2 brilliant seasons with the Padres, but it wasn't until he got to Atlanta and playing on national TV virtually every night that he started to gain some attention.

McGriff seems to yearn for one truly superb year, the kind that would finally convince everyone that he's among the best. But if he doesn't get it, that's OK.

"I want to have that spectacular year, but when I walk away from this game, I want them to be able to say, 'Fred, he was consistent day in and day out.'"



Summary Planning Sheet

Name of Source _____ Date _____

Title of Selection _____ Author _____

Main Idea _____

Supporting Details or Most Important Facts _____

Unfamiliar Words or Phrases _____

Method Used to Present Information _____

Draft Summary _____



Application

Select a story, chapter, or article that you are expected to read for one of your classes. Read and **summarize** your selection. Include the summary in your portfolio or journal.

Summary Planning Sheet

Name of Source _____ Date _____

Title of Selection _____ Author _____

Main Idea _____

Supporting Details or Most Important Facts _____

Unfamiliar Words or Phrases _____

Method Used to Present Information _____

Draft Summary _____



Evaluating What You Read: Recognizing Fact and Opinion

Much of what you read has been written by people who hope to convince you that one particular opinion, idea, or commercial product is better than another. Many of these writers are quite skillful with words. For this reason, you must learn to *evaluate* reading materials in order to determine whether the content is *reliable* or *prejudiced*. Such evaluations will also help you to understand the writer's purpose and reasons for presenting information in the manner the writer presents it.

In order to evaluate a piece of writing you must decide whether what is being said is true or not. A good reader draws upon her knowledge in order to decide if something is true or not. Each time you read, you bring your store of knowledge to the facts and ideas expressed in the selection you are reading. You are constantly comparing what you know with what you read or hear. After making this comparison, you decide if a statement is true or false.

Consider the following statements:

The first bicycle was invented by Karl D. von Sauerbronn in Germany in 1816.

The new Macro Auto 9000 fits everyone's lifestyle and everyone's pocket.

Even though you may not know for sure that the first statement is true, you could easily check by looking it up in an encyclopedia or almanac. Your previous knowledge probably told you that this statement is probably true because the facts are verifiable.

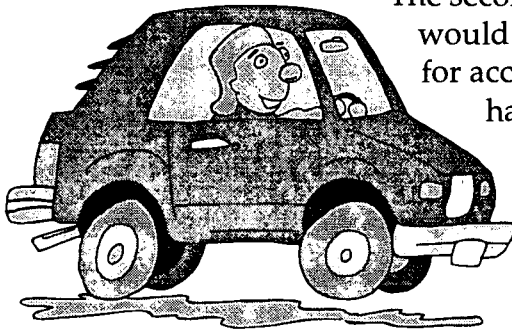

The second sentence is probably not true. It would be very hard to check this statement for accuracy. In order to do so you would have to match the car to every single person's lifestyle and income. Even without checking, your previous knowledge probably told you that not everyone can afford a car nor would one car ever be able to fit everyone's wants and needs.



Ask yourself the following questions when evaluating something you are reading:

1. What is the author's purpose in writing?
 - Is the author trying to convince you to change your mind about something?
 - Is the author angry about an injustice and hoping to have this injustice corrected?
 - Is the author attempting to sell or promote a product or idea?
2. Are the statements true?
 - How do these statements compare to what you already know?
 - What facts does the author use to support or justify the statement?
 - Do these facts justify the author's opinion?
 - Is the author qualified to make these statements? If so, how?
3. Do the statements make sense?
 - Does the author recognize the other side of the position?
 - Can you tell which side of the argument or position the author favors?
 - Are the reasons for favoring this position understandable and clearly stated?
4. What techniques does the author use to convince you of her point of view?
 - Does the author appeal to your vanity?
 - Does the author assume that the reader has certain biases and prejudices?
 - Does the author emphasize or leave out important facts in an effort to influence your thinking?
5. How effective are the techniques the author uses?
 - Do you feel inclined to agree with the author's argument?
 - Do you feel insulted or angry in any way because the author assumed you possessed certain biases or opinions?
 - Has the author touched on certain likes, dislikes, or fears that you have about a certain subject?



Practice

Read each of the following statements. Then, based on what you know, write T for true and F for false. Remember: In order to be true, a statement must always and under any circumstance be true.

- _____ 1. Boys are always better math students than girls.
- _____ 2. Smoking is a cause of lung cancer and emphysema.
- _____ 3. Everyone who smokes will fall victim to either lung cancer or emphysema.
- _____ 4. Graduating from high school guarantees that you will be accepted into college.
- _____ 5. Young men must register for selective service upon turning 18 years of age.
- _____ 6. It is illegal to sell alcohol to minors.
- _____ 7. Tallahassee is the capital of Florida.
- _____ 8. The sun always shines in Florida.
- _____ 9. Big Bear Tires are bigger and better than any other tires on the road.
- _____ 10. The Earth revolves around the sun.



Application

Find two editorials or letters to the editor in your local newspaper that present two opposing views on the same subject. Read each editorial or letter and answer the questions that follow.

1. What is the author's purpose in writing this piece?

Item A: _____

Item B: _____

2. Are all of the statements true?

Item A: _____

Item B: _____

3. Do all of the statements make sense?

Item A: _____

Item B: _____

4. What techniques (prejudice? vanity? fear?) does the author use to convince the reader?

Item A: _____

Item B: _____

5. Are the techniques effective? Why or why not?

Item A: _____

Item B: _____

6. Use the answers to the questions above to write a paragraph that explains which article is more effective and why.

Unit 2: Writing— Making Words Speak





Unit 2: Writing—Making Words Speak

Overview

In this unit you will learn how to build on the writing skills you already have. One of the most important writing skills is shaping your writing for specific readers. Most likely, this is a skill that you have been using much of your life. For example, contrast a note you passed to a friend during class with a thank-you note you sent to a grandparent or other adult. These two notes were probably very different because the two audiences, or the readers of these documents, were very different. You may have used shorter sentences and included slang in the note to your friend. On the other hand, you may have been more careful with grammar and spelling in the letter to the adult. In each instance, you were adjusting your writing to meet the needs of your audience.

At the end of this unit you will have produced two documents on the same topic. The topic for these two documents will come from policies in your student handbook. Both of these documents will present your opinion about the policy you have selected. However, each document will be different because it will be written for a different audience.

This unit will take you through the series of steps to use when writing your document. The steps and skills that are included in this process can be used anytime you need to write anything, regardless of the topic or subject.



Vocabulary

Study the vocabulary words and definitions below.

- chronological order** the order in which things occur according to time
- clustering** placing ideas and notes around a central idea
- detail sentences** sentences in a paragraph that discuss, explain, and/or support the paragraph's topic sentence
- expository writing** writing intended to explain something or inform readers
- graphic organizer** pictures that show a plan for combining and arranging information and ideas
- persuasive writing** writing intended to convince readers of an opinion, a claim, or to take a particular action
- topic sentence** the sentence in a paragraph that tells the central idea of the paragraph
- useful topic** a topic that has been limited and that points to something specific about the general topic



Prewriting: Sharpening Your Point, Gathering Materials

The first step in the writing process is to decide what you are going to write about. This step is called *selecting the writing topic*. In most cases, you will be given a general topic. For instance, your social studies teacher may assign you to write an essay on the city in which you live. As you begin to collect information on your city, let's call it Dynamotown, you quickly realize that this topic is too broad. It would take many books to hold everything there is to say about Dynamotown. There is the 200-year history of your city—when and how it was founded, for example. There is the geography of Dynamotown—including its waterways and climate. There is the government of Dynamotown—whether it has an elected mayor or a city manager. The list goes on and on ... and on. Most likely, your problem will be that there is too much to say about Dynamotown, rather than too little.

Your first task, then, is to narrow this topic—the city of Dynamotown—into a **useful topic**. A *useful topic* points you in a specific direction and zeroes in on a specific part of the general topic. Limiting your topic provides you with something specific to research, think about, and then write about.

Imagine that during your reading on Dynamotown you discover that much of Dynamotown was once under a wide river. At the beginning of the twentieth century, dikes were built to narrow the river. These dikes doubled the size of Dynamotown. Imagine, where your house now stands there was once nothing but water!

In this example a topic that was too broad to manage—the geography of Dynamotown—has been made into a useful topic—how and why these dikes were built. A good way to develop a useful topic is to find something specific that interests you or that makes you feel emotional.

Select a topic that you are interested in. Your interest and enthusiasm about the topic will help you write an essay that appeals to your readers. Imagine your teacher's and classmates' delight to discover that years ago a part of the city had quite a different kind of school—a school of fish!



Select a topic that makes you feel emotional. You may want to develop a topic on which you have a strong pro or con feeling. For example, imagine that Dynamotown is being considered for a nuclear dump. You have studied the effects of nuclear dumps on surrounding areas. You have concluded that a nuclear dump would harm the groundwater in Dynamotown in years to come. Your feelings about this issue can be used to fuel the work you will do on this essay.



Application

Read your school's student handbook. While you are reading, choose three **topics** that you find interesting or that move your emotions. List these three topics under **General Topics** in the chart below. If your topic is already specific enough, list it under **Useful Topics**. If your topic is not specific enough, limit it in some way and then list it under **Useful Topics**. The chart below provides you with examples of how general topics can be shaped into useful topics.

General Topics	➔	Useful Topics
The geography of Dynamotown	➔	How and why dikes were built
The effects of a nuclear dump on Dynamotown	➔	The effects of a nuclear dump on the groundwater of Dynamotown
Newborn babies	➔	What a baby is able to see in the first year of his or her life
Education in the United States	➔	How and why public education began in the United States
Gardening	➔	How to grow an organic garden
Basketball	➔	How Wilt Chamberlain changed the rules of basketball
	➔	
	➔	
	➔	

Now think about your three useful topics. Which of these inspires your interest and emotions the most?

My useful topic is _____.



Gathering Information: Going to the Right Source

The next step in the writing process is to gather information to use in the text of the final product. The type of materials you choose to use depends on the kind of writing you are doing. If you are writing a factual research paper, you will want to use materials that are reliable and factual. If you are writing a paper that expresses your opinion on an issue, you will want to use resources that address your ideas. If you are doing creative writing, you will probably want to use a dictionary and a thesaurus. It is important to understand the kind of writing you are doing in order to select appropriate materials.

The act of sorting and selecting the information to use in a document requires the writer to understand the material completely. There are many strategies you can use to help you fully understand the material you are reading. There are also strategies you can use to help you select and organize information once you start to write the draft of your document.

Notetaking: Making Information Manageable

Unless you have a photographic memory, making notes is an essential skill for you to master. Making notes is a way of storing information that you might need later. Although notes will help you do well in class and on tests, they are also helpful in the world of work and everyday life. Think for a minute about all the things you will have to remember when you are an independent adult. At home you will have bills to pay, appointments to keep, and groceries to buy. At work you will have tasks to complete, things to learn, and meetings to attend. Making good notes will help you keep your life organized.

Making good notes as part of the writing process provides you with a warehouse of information. Make good notes by jotting down the main ideas and supporting details while you read material that is related to your topic. Once you have read and made notes on your material, you will be ready to organize your information in a logical fashion. Good notes lead to good organization, which leads to a well-written paper.



NOTETAKING GOALS

Notetaking helps you to...

1. remember
2. organize
3. understand
4. summarize
5. review

Notes should be legible, brief, and comprehensive. Use the following tips when taking notes.

Tips for Making Notes

- Reread before making notes. You may find it helpful to read something the first time to get a general impression of the contents, and then read it a second time for more specific information.
- Remember your topic and select the information that relates to that topic. Do not make the mistake of writing down everything there is to write down.
- Complete sentences are unnecessary unless it is a sentence that you want to use as a quotation. If you are going to copy the sentence as a quotation, remember to write down the name of the author, title of the book, publisher, date of publication, and page number(s) so you can give credit to the source of the quotation.
- Cluster your notes according to main ideas. (See page 92.)



Writing Notes on Paper: Tips of the Trade

Writing notes is easier if you divide your paper in half lengthwise and draw a line down the center of the page. On the left side include headings, subheadings or key words, page numbers, and notes to yourself. On the right side include the main ideas. Below these main ideas, use dashes to indicate important supporting details.

		September 29	
		World War II	
Heading	→	The Forces	
Subheading	→	Allies	U.K., U.S., France, USSR—
Page on which information is located	→	See p. 10	overcame great obstacles to gain victory ← Main idea
Note to yourself	→	When did U.S. & U.S.S.R. become enemies?	- set aside any differences to fight a common enemy ← Supporting detail
			- had strong support from their civilians ← Supporting detail
Subheading	→	Axis	Italy, Germany, Spain—
Page on which information is located	→	See p. 12	all were run by dictators = ← Main idea
Note to yourself	→	Why would the people in these countries let a leader take away all their rights?	- killed or imprisoned those who did not support them ← Supporting detail
			- had total control over their countries ← Supporting detail



Practice

Practice taking notes on the following paragraphs. Remember to include main ideas and supporting details.

It is a privilege, not a right, for students to drive and park on campus. The campus parking facilities are the property of the Leon County School Board. All users are subject to the authority of the LCSB and the individual school principal/designee. The Leon County Sheriff's Department has law enforcement jurisdiction over the parking facilities. Students must have a valid permit to park on campus. Parking permits may be suspended or revoked for vehicle-related misconduct.

Basic eligibility for a permit is to have and maintain a 2.0 weighted grade point average, have a valid Florida operator's licence, and not have any student obligations. A regular permit costs \$10 for the year, and a temporary permit is \$3 per week.



Illegally parked vehicles will be towed at the owner's expense as per School Board Policy 5.18 and Florida Statute 715.07.

<input type="checkbox"/>	
<input type="checkbox"/>	



Application

Reread and take notes on the sections in your student handbook that discuss your topic.



Organizing Information: Each in Its Own Place

Now that you have identified your topic and learned to make good notes from a variety of sources, you are ready to organize your information. When you organize your information, you are grouping your information. All the information that is similar is grouped together. Think of sorting any collection of objects, such as sporting equipment, into large baskets. In one basket you would toss all your rollerblading equipment. In another basket you would toss all your basketball stuff, and so on. In a similar way, when you organize information, you drop all related information into the same slot.

Graphic Organizers: Seeing Before You Write

A large amount of information can be organized very quickly by using **graphic organizers**. *Graphic organizers* are pictures that show a plan for combining and arranging information and ideas.

There is no one way to create a graphic organizer. The shape and size of the graphic organizer is determined by the writing topic, number and types of details, and writing style and purpose. Because these things vary from writing to writing, the graphic organizers that writers create will vary also.

The one thing that all graphic organizers have in common is **clustering**. When clustering, the writer lists a central idea and then gathers ideas into clusters around this central idea. You can cluster ideas while you are making notes if you already know the central ideas of your document.

Consider Dale, who wants to be a nurse after he graduates from high school. He is writing an essay on “Nursing” to inform others and himself. He has collected information on nursing education, kinds of nurses, and work settings, so he decides to cluster his information around these central ideas.

Clustering is an excellent way to organize information before you begin to write. By looking at the example on the next page, you can tell that this writer is going to write a report on a school’s attendance policy. You can tell that he will write one paragraph on what state law says about school attendance and one paragraph on school rules regarding attendance. You can also tell what specific details he will use in each of these paragraphs.



Graphic Organizer

Step 1: Record your writing topic.

Attendance Policy

Now ask yourself: "What are my largest groupings of information?" These become your main ideas.

Step 2: Record the main ideas.

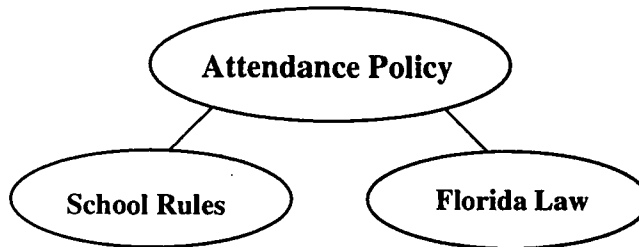

Now ask yourself: "What pieces of information or ideas belong to each main idea?" These become your supporting details.

Step 3: Add supporting details.

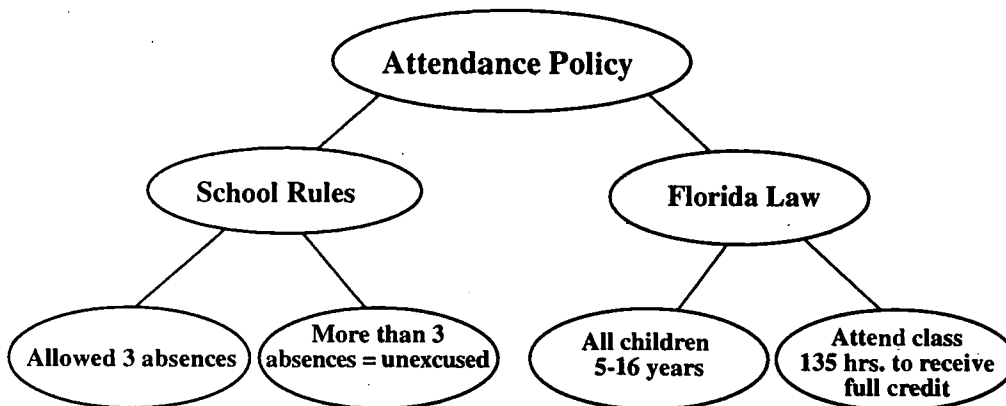

Now you are ready to write!



Practice

Study the graphic organizer below and complete the directions that follow.

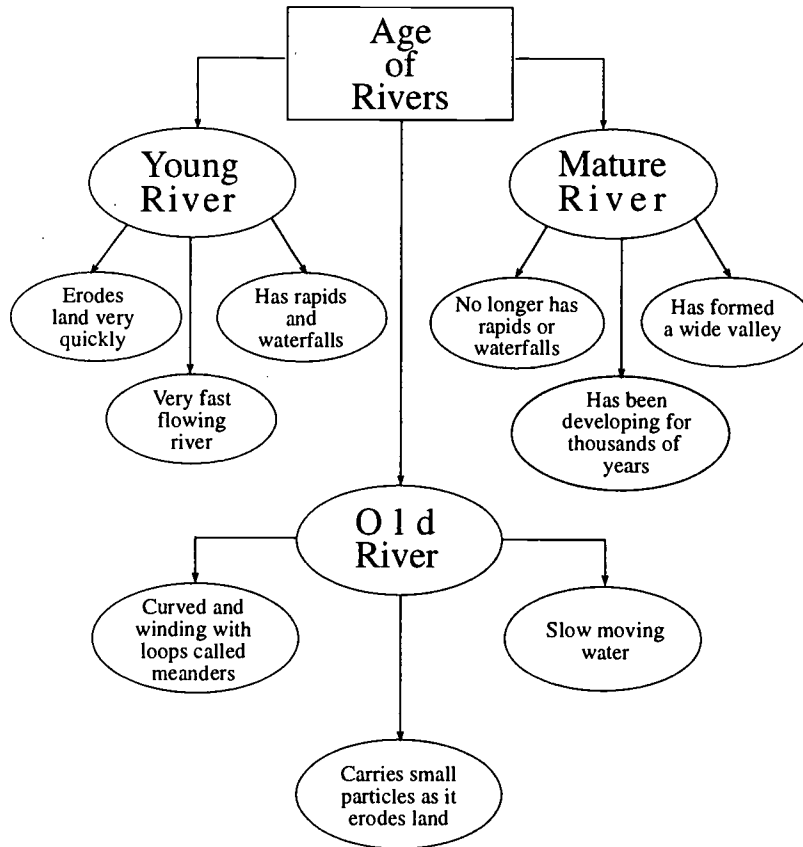

1. Circle the writing topic.
2. Draw a box around the main ideas for the three paragraphs.
3. Draw a line under the details that will be included in each of these three paragraphs.

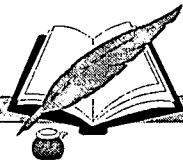

Practice

Complete the notes below using the following organizer.

The Supreme Court

The Supreme Court consists of nine justices. The justices select, decide, and explain cases. When they decide cases, they follow certain steps. First, they read written briefs presented by lawyers for both sides. Second, they hear oral arguments presented by lawyers. During oral arguments, justices can question and challenge the lawyers on both sides. On Fridays, justices hold conferences. They discuss cases in private; these discussions are not recorded. A majority vote determines the Supreme Court's decisions. Finally, the justices issue a written statement, called *an opinion*, to explain that decision.

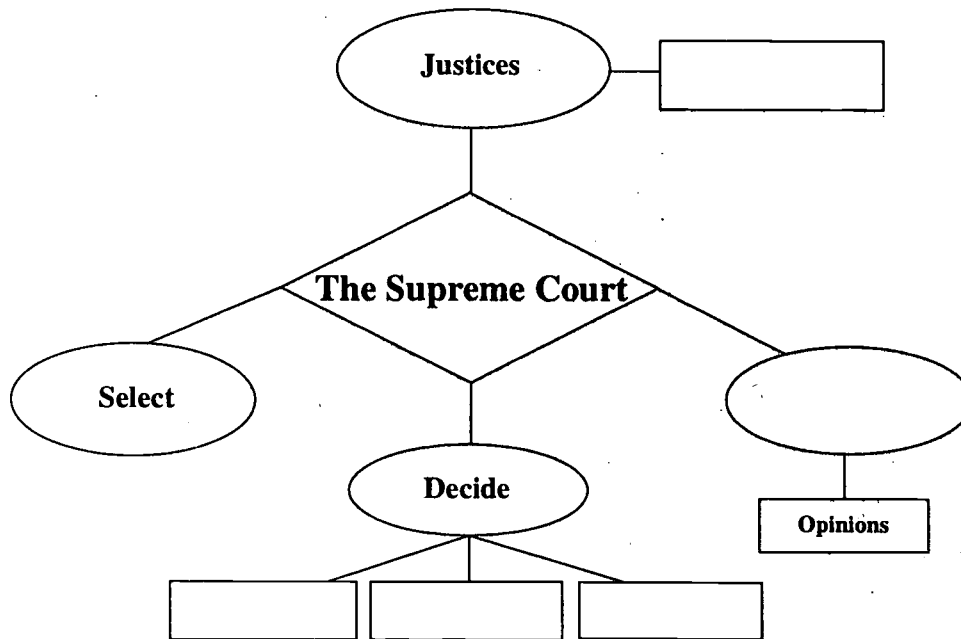



Practice

Use the notes on the previous page to complete the **organizer** below.

Supreme Court	
9 Justices →	1. Select cases
	2. Decide cases
	A. Read written briefs (both sides)
	B. (Justices can question)
	C.
Majority vote wins	3. (opinion)



Application

Review the notes you took on page 94. Organize your notes using an appropriate method.



Writing for an Audience: Tailoring Your Words and Content to Fit Readers

Have you ever talked to someone who uses words and sentences you didn't understand? Maybe someone was using words like *busker* (a wandering musician) or *peripatetic* (walking about from place to place) or *erudition* (rich and vast knowledge). Perhaps, after you mentioned that your favorite band was playing in sixty-five cities in the next fifty-three days, someone said: "I am sure that these peripatetic buskers will acquire erudition about many geographical locales." You probably came away from this talk wondering what the other person was talking about. This speaker had expressed himself in correct English. However, he missed one of the most important points about communication. He failed to change his words

to suit his audience. If we choose words and sentences that the other person cannot understand, we fail to communicate. The speaker in the example above should have said:

"These musicians certainly like to travel from place to place. I hope they learn about the places they see."

A speaker must also include the right amount of information to make his message clear. Imagine that a friend has given you

directions to his house. He gave his street address and even the color of his house. But, he did not tell you about the confusing one-way streets that wind through his neighborhood. When you tried to get to his house you became lost because the speaker hadn't given you enough information.

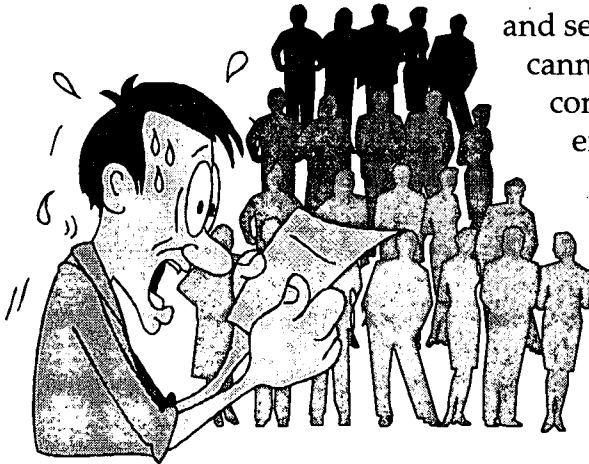

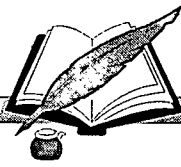

In order to write well you must use words that the reader can understand. You must also give the reader the right amount of information.

Writing for an Audience

words—choose words that your readers can understand and that are right for the particular writing situation.

information—include the right amount and kind of information your readers need to understand your document.

Remember: Everything you write has an intended reader or audience—one or more persons who will read what you've written.

Before you begin to write ask yourself the following questions:

Who are my readers?

Are they your classmates, teacher, parents, best friend, the readers of a particular magazine, or the readers of "letters to the editor" in your local paper?

What do I know about these readers?

Are they young or old? How much formal education have they had? What kinds of experience have they had? How do they feel about the topic? What do they already know about the topic? Are they already interested in the topic or will you have to generate their interest?





Practice

Read the following paragraphs. Circle the letter that identifies the best audience for each.

1. It depends what kind of food you like. If you enjoy Italian food, try Rosa's Restaurant. Everybody loves Rosa's food. To get there, go east on this road, Main Street, to Highway 29. At the intersection you'll see a giant plastic, turquoise elephant. His trunk points north on Highway 29. Go north on Highway 29 for three miles. You'll see Rosa's on the left.
 - a. The audience is someone who lives in your hometown or city.
 - b. The audience is a visitor to your hometown or city.
2. A *story* has a plot and one or more characters. The plot includes the events and actions, and the order in which they occur.
 - a. The audience is a child in preschool.
 - b. The audience is a junior high or high school student.
3. You and your team try to hit the ball over the net. Then the team on the other side will try to hit the ball back over the net.
 - a. The audience is an adult who wants to improve her volleyball skills.
 - b. The audience is a young child who doesn't know how to play volleyball.
4. Think about your heart as being like a pump. It pumps blood through your blood vessels, just like a water pump pushes water through pipes.
 - a. The audience is a student studying to be a doctor.
 - b. The audience is a child.

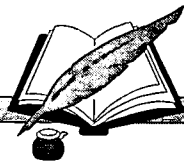

See Your Readers: Predicting Your Readers' Response

As you write, imagine how your readers will react to what you've written. You might, for example, write a sentence to a prospective employer that reads: "I think your company makes an awesome product, and I would like to join your sales force!" The word *awesome* is too informal for this situation. Your future employer would react more positively if you had used the phrase *a valuable product*. Replace the phrase *an awesome product* with the phrase *a valuable product* to fit the situation.

Read the three writing samples below. Each was written for a different audience. Notice how the word choice and information is different in each.

(a) *Dear Grandma and Grandpa,*

I am so excited about my upcoming trip that I can barely think of anything else. Next week my entire class is going to Washington, D.C., for three days. First, twenty-five of us will ride through the night on a bus—we've taken an oath not to sleep the whole way there. . . .

*Love,
Kerry*

(b) *Dear Genoa,*

It'll be the coolest, though I'm fried from the excitement! We're bolting for the cap next week. Yo, Mr. Prez and Mr. Vee Pee, clear your calendar, the Sand Beach High Marauders are stopping by. Maybe the Prez will jam with us—he can front me an extra sax! Wicked time. Wonk boy no more!

*See ya,
Kerry*

(c) *MONDAY: 6:30 A.M.!*

In example (a) above Kerry is using popular English because he is writing to his grandparents. In example (b) Kerry is using slang because he is writing to his best friend. In example (c) Kerry is simply writing a short reminder to himself.

What Kerry has done in these three examples is no different from what you do all the time. Just listen to the way you explain an upcoming Friday night party to your parents as opposed to your friends.



Practice

Below are pairs of **synonyms**. Circle the synonym in each pair that would be most appropriate for a **formal essay** written for a teacher.

- | | |
|-------------|------------|
| 1. confused | spaced out |
| 2. wheels | car |
| 3. split | exited |
| 4. clear | cool |
| 5. bread | money |

Write a **slang** word or phrase for each of the following.

- hello: _____
- hat: _____
- graffiti: _____
- wonderful: _____
- handsome or beautiful: _____
- good: _____
- man: _____
- girl: _____
- car: _____
- parents: _____



Application

Using your notes from page 94, list on the chart below words, phrases, and other information that will be used for each audience.

Classmates

School Administrators

222



Writing a First Draft: Beginning to “Speak” to Your Readers

So far in this unit, you have created a useful topic, made good notes from your sources, organized these notes, and learned to write for a particular audience. You are now ready to write a first draft.

Most first drafts are messy. When you write a first draft, you take your organized notes and mold them into sentences and paragraphs that make sense to the reader. It is almost impossible to get this perfect the first time you try! You will find that as you are writing a first draft, you will think of changes to make your document better. The first draft is the perfect way to try different words, reorganize sentences, or add details to make your document say exactly what you want it to say.

Developing a Paragraph: Lead with a Topic, Follow with Details

A *paragraph* is a group of words, phrases, and sentences that develops a central idea. Although the length of a paragraph can vary greatly, a standard paragraph is usually made up of four or more related sentences. (However, some paragraphs may be shorter, and some paragraphs may be longer.) One of the sentences in a paragraph tells what the paragraph is mainly about. This sentence is called the *topic sentence*. Other sentences in the paragraph are **detail sentences**, and they give specific information about the topic sentence. Many paragraphs also have a *concluding sentence* that summarizes the paragraph by restating the central idea. The topic sentence and the concluding sentence are the most general statements in a paragraph.

Details give the reader the information they need to understand the central idea of a paragraph. The message you want to convey and the audience to whom you are writing will point you to the right details to use in your paragraphs.

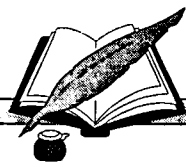

There are many different ways to provide details in a paragraph. The categories below are some of the most common and effective ways of developing detail sentences.

1. **Definitions.** Use a definition to define a word, a process, or a concept.

Example: A decade means ten years.

2. **Descriptions.** Use a description to explain what something looks like, feels like, sounds like, tastes like, etc.

Example: The rotting fish was mottled and covered with algae.

3. **Examples.** Use an example to give readers a specific instance.

Example: A ball tossed into the air shows the force of gravity.

4. **Facts.** Use a fact to support an opinion or claim you are making.

Example: The timer on the security camera shows that they got home before 8:00 PM.

5. **Statistics (numbers or percentages).** Use statistics to prove what you are claiming is correct.

Example: Twenty percent of the class got an "A" on the test.

6. **Reasons or Causes.** Use a reason to justify a statement.

Example: Driving under the influence can cause accidents.

Sometimes writers have a hard time including enough details to support a main idea. If this happens to you, check the list above for ideas on the kinds of details you could add to your paragraph.

Remember: Readers need clear and accurate details to understand what you have written.



Study the example below of a paragraph that has a topic sentence followed by detail sentences. The topic sentence is italicized.

Until about 150 years ago, most parents thought of and treated their children as younger adults. Many children worked right along side of their parents as soon as they were old enough to work. If the father was a cobbler, his children most likely helped to make and fix shoes. Parents who worked in factories thought themselves lucky if they could get their children jobs working right along side of them. Parents even took their children to parties at which beer and liquor were often served. Children did not have lengthy childhoods, as we might imagine.

Notice that the *topic sentence* clearly states the main idea of the paragraph. It helps readers prepare for what follows: Readers expect that the sentences that follow, *the detail sentences*, will discuss, explain, and support how children were treated as “younger adults.” Read the paragraph again, and note how each detail sentence refers to the topic sentence.



Practice

Write a detail sentence for each of the following main ideas.

1. Youth does not always depend on how old you are.

Detail sentence: _____

2. My bike trip to the top of Grandfather Mountain was the most exciting experience of my life.

Detail sentence: _____

3. Cigarettes are killers.

Detail sentence: _____

4. Getting even is not the way to end violence.

Detail sentence: _____

5. Imagine what it would be like to live in a world where we didn't know how to write.

Detail sentence: _____



Practice

The following paragraphs were written by students. Underline the **topic sentence** in each paragraph. Draw a line through any sentences or phrases that do **not** belong.

Making Peace

Learning to make peace with people I dislike is not easy, but I have learned how. First I discovered that just because I don't like someone is no reason to fight with him or her. I like a lot of people, including everyone in my math class. Not everyone is someone I want to be friends with, and that's OK. I've learned to respect people I have little in common with. As long as I respect others, I am able to talk out my differences with them. If nothing else works, we go see a counselor or teacher to help us avoid a fight.

Turn it Off!

For a long time now, once I turned the TV on, I just sat and watched, even when there was nothing I liked on. I like many things on TV. One good show that just came on is *Flying to the Moon*. Then one night the electricity went off and I couldn't watch. So I found something else to do. The next night I watched a show I liked and then I just pushed the remote control and shut the TV off. It was too quiet for a few minutes, but I waited it out and started to like the silence. Now, whenever I realize I'm just turning into mold on my couch, I find something real to do.

Football Fouls

There are many penalties or fouls in football. One of the penalties is holding. Holding is called when a player holds or pushes down another player. Another penalty is offsides. This foul is called when an offensive or defensive player moves beyond the line of scrimmage before the ball is snapped. Another penalty is facemasking. Facemasking is called when a player grabs hold of another player's facemask. Players must know many rules to avoid making penalties.



Paragraph Types: Explaining and Persuading

Paragraphs are written for many different reasons or purposes. You might want to describe how something looks, give directions to a specific place, or tell someone about something you did. In each of these cases you are attempting to inform your reader about something. This kind of writing is called *expository writing*.

Another kind of writing is called *persuasive writing*. We use persuasive writing to convince readers to agree with our opinion on a particular issue. Persuasive paragraphs are written to convince readers to change their habits, agree with an opinion, or believe in a particular way.

No matter what the reason for writing, all good writing is well organized. When you organize a paragraph, you answer the questions: "Which sentence or piece of information goes first? Which sentence or piece of information goes second?" You ask as many of these questions as you have sentences or pieces of information. A well-organized paragraph has at least two and often three parts.

- The first part is the *topic sentence*, which tells the reader the main idea of the paragraph. This statement also states or suggests how the rest of the paragraph is ordered.
- The second part is the *body* of the paragraph. It usually includes details that support and explain the main idea.
- Some paragraphs also need a *concluding statement*. It may summarize a very long paragraph, or it may reach a conclusion, if the paragraph calls for one.

When you begin a paragraph with a topic sentence, you help your reader anticipate what is in the paragraph and how it is ordered. For example, consider the following opening sentence of a paragraph: "Reducing the fat in your diet will improve your health in three ways." Note how many things you would already know about the content and organization of the rest of the paragraph. You would know that the main idea is how reducing your fat intake will improve your health. And you would expect that the paragraph is organized according to the three ways that reducing fat intake will improve your health. First you will read about one way, then a second way, and finally a third way. As you can see, the reader-friendly paragraph has at least these three characteristics.



- Your topic sentence explains your topic and the organizational pattern of the paragraph.
- The words and sentences are clear and written at a level your particular readers can understand.
- The sentences following the topic sentence follow the pattern you've stated or suggested in your topic sentence.

Expository Writing: Delivering Information

Expository writing explains something to the reader by using facts and ideas to clarify or support the information. Another word for *expository* is *explanation*. Remember: When you give an explanation, it should be clear and well organized. Use the steps below to help you build expository paragraphs that will leave your readers saying: "Yes, I understand! This paragraph is like a good meal. It has all the right dishes, and they have been served in just right the order!"

Building an Expository Paragraph

1. Before writing, determine your audience.

- a. Determine your audience for this paragraph. Determine what kinds of words and sentences the audience can understand.
- b. Decide what the audience knows about the subject. Explain any terms or ideas the audience is not familiar with.

2. Construct a topic sentence.

- a. State the main idea of the paragraph.
- b. Let the reader know how the information is organized.

3. List supporting details.

Use details that support the purpose and main idea of the paragraph. Types of details include the following:

- definitions
- descriptions
- examples
- facts
- reasons

4. Deliver the supporting details in the right order.

- a. If the details are steps in a process, then list them accordingly.
- b. If no order is obvious, use your best judgment. Try ordering the details in different ways, and then select the order that will best help your readers grasp the content.

5. If necessary or helpful, develop a concluding sentence.

- a. Reach a conclusion.
- b. Suggest any future courses of action.
- c. Summarize the details.
- d. Restate the topic sentence.



The expository paragraph below describes the scientific method. The scientific method is a way to answer questions by using logic and experimenting to find facts. The paragraph includes all the necessary sentences to make it an effective expository paragraph. However, the paragraph's original order has been shuffled. Consequently, it is poorly organized.

If your conclusion continues to prove true in your and other scientists' experiments over a long period of time, then you can construct a theory that answers your question in a general way. This possible answer is called a hypothesis. Then you carry out an experiment to test your hypothesis. First you identify a problem—a question that you think you can answer through further investigation. The scientific method insures that the answers we find to our questions and mysteries will be accurate and, most likely, useful. Through observations of the results of your experiment, you draw a conclusion. The scientific method involves several steps. Next you gather more information to determine a possible answer to your question.

All the information is here, but it is practically useless to a reader because it is poorly organized. Now read the same sentences in their correct order.

The scientific method involves several steps. First you identify a problem—a question that you think you can answer through further investigation. Next you gather more information to determine a possible answer to your question. This possible answer is called a hypothesis. Then you carry out an experiment to test your hypothesis. Through observations of the results of your experiment, you draw a conclusion. If your conclusion continues to prove true in your and other scientists' experiments over a long period of time, then you can construct a theory that answers your question in a general way. The scientific method insures that the answers we find to our questions and mysteries will be accurate and, most likely, useful.

Now the reader can easily understand and use this expository paragraph. It contains all the characteristics of a good paragraph. As you read again the steps for building an expository paragraph, study the analysis of the well-organized paragraph on the scientific method.



Building an Expository Paragraph

1. Before writing, determine *your audience*.
 - a. Determine your audience for this paragraph. Determine what kinds of words and sentences the audience can understand.

The paragraph on the scientific method was written for students just like you. The author chose words and sentence structures which fit the reading ability of high school students. In other words, she tailored the paragraph to you—her readers.

- b. Decide what the audience knows about the subject. Explain any terms or ideas the audience is not familiar with.

The writer assumed you were just learning about the scientific method. Therefore, she took you through the steps, explaining each one in nonscientific terms. When she did use a term you might be unfamiliar with—*hypothesis*—she defined it.

2. Construct a *topic sentence*.
 - a. State the main idea of the paragraph.

The main idea is clearly stated in the first (and topic) sentence: the many steps of the scientific method.

- b. Let the reader know how the information is organized.

After reading the topic sentence, readers know that the paragraph will be organized according to the several steps of the scientific method. Readers could anticipate that there will be a first step, a next step, and so on.

3. List *supporting details*.

Use details that support the purpose and main idea of the paragraph. Types of details include the following:

- definitions
- descriptions
- examples
- facts
- reasons



(The phrase *scientific method* was already defined for readers in an earlier paragraph.) The writer *defined* the word *hypothesis* because she is writing for readers who may not know the term. She also *described* each step in the scientific method. All expository paragraphs must use one or more of the types of details listed above.

4. Deliver the supporting details in the *right order*.
 - a. If the details are steps in a process, then list them accordingly.
 - b. If no order is obvious, use your best judgment. Try ordering the details in different ways, and then select the order that will best help your readers grasp the content.

This paragraph presents the steps of the scientific method in the exact order followed by a scientist or researcher. Notice how the author clearly tells readers when she is moving from one step to another. Words such as *first*, *next*, and *then* work as road signs so readers don't lose their way.

5. If necessary or helpful, develop a *concluding sentence*.
 - a. Reach a conclusion
 - b. Suggest any future courses of action.
 - c. Summarize the details.
 - d. Restate the topic sentence.

The concluding statement in this paragraph reaches a conclusion: A scientist follows the scientific method to insure that her answer to a question or mystery will be accurate.

Chronological Order in Expository Writing: Going by the Clock, the Calendar, the Decade

Many expository paragraphs use **chronological order** to present facts and ideas. *Chronological order* means "time order." If you use chronological order in a paragraph, you organize the supporting details according to when they happened. Listed on the following page are some key words to use in a paragraph organized in chronological order.



Key Words to Chronological Order

first	until
after	instantly
before	at the same time
when	then
finally	later
next	now
immediately	last

You would likely use chronological order in a history class if your teacher asked you to write an expository paragraph that explains a cause of the American Revolution. Your outline might look like this:

Topic Sentence: One of the major causes of the American Revolution was the harsh taxes the British government forced the Colonists to pay.

- A. First — Sugar Act 1764
Key Word
- B. Then — Stamp Act 1765
Key Word
- C. Later — Tea Act 1773
Key Word

Concluding Sentence: Finally, the Acts passed by the British government pushed the Colonists into protesting.

Remember: To use chronological order in an expository paragraph, simply order your supporting details according to time.



Practice

*The following paragraph is missing words that tell **chronological order**. Use words from the chart on page 116 to fill in each blank below.*

I was in a terrible accident Saturday night. It was a very dark and rainy night, and I had a hard time seeing the lines on the highway. Just as I was about to enter a curve, I lost sight of the lines completely. _____ I knew I was in big trouble. What happened _____ was a nightmare. A large cement truck was in my lane. _____ I slammed on the brakes. _____ I began to fishtail and lose control of my car, so I let up on the brakes. The _____ thing I remember is seeing a large tree coming straight at me. I am still shaken up about the whole ordeal, but at least _____ I can talk about it.

*Write a paragraph that shows the **chronological order** of an event in your life. Use key words to tell the order.*



Application

Practice writing an **expository paragraph**. Choose one of the following topics or one of your own with teacher approval; then fill out the form below. Refer to *Building an Expository Essay* on page 113.

- Science**
1. Explain how clouds are formed.
 2. Explain how a tree gets its nourishment.
- Social Studies**
1. Explain how a political candidate is elected.
 2. Explain the causes of the Civil War.
- Math**
1. Explain how to convert fractions to decimals.
 2. Explain how to do long division to a class of 4th graders.
- Art**
1. Explain the steps an artist takes to paint a picture.
 2. Explain how to make a music video.

Before you write...

Purpose: _____ *to explain* _____

Audience: _____

Main Idea: _____

Topic Sentence: _____

Supporting Details: _____

Concluding Sentence: _____

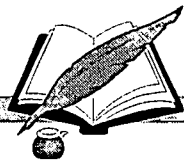

Persuasive Writing: Offering an Opinion

Persuasive writing tries to convince or persuade the reader that the writer's opinion is the best one. A persuasive paragraph is written and organized similarly to an expository paragraph. The main difference is the purpose of the paragraph. In a paragraph written to support an opinion or claim, your purpose is not simply to explain, but to persuade.

Use the steps below to help you build persuasive paragraphs that will leave your readers saying: "Yes, I'm convinced of your opinion! This paragraph is like a good meal. It has all the right dishes, and they have been served in just right the order!"

Building a Persuasive Paragraph

1. Before writing, determine your purpose and audience.

- a. Determine the opinion you want the audience to accept.
- b. Determine your audience for this paragraph. Determine what kinds of words and sentences the audience can understand.

2. Construct a topic sentence.

- a. State the opinion the paragraph will argue for.
- b. Let the reader know how the support for your claim will be organized.

3. List supporting details.

Use evidence that supports the claim you have made in your topic sentence. Types of evidence include the following:

- definitions
- descriptions
- examples
- facts
- reasons

Organize this information in a logical, clear way. Keep in mind that you want your readers to agree with you; they should be able to easily follow your argument.

4. Deliver the evidence in the right order.

- a. Order the evidence according to strength: the strongest first, the second strongest next, etc.
- b. If all evidence is equally strong, use your best judgment. Try ordering the evidence in different ways, and then select the order that will best persuade readers of your claim.

5. Develop a concluding sentence.

- a. Restate your opinion and summarize your supporting evidence.
- b. Suggest ways in which your readers can actively support your opinion.



Imagine you are given the following paragraph on why you should elect Juanita as president of your school's student council. As you read, ask yourself: "Are there good reasons why I should vote for Juanita?"

Juanita is the best choice for president of our student council. Let me say it again: She is the best! I know her and you can take my word for it. She's done many good things for our school. Also, she cares about our school and her fellow students. Elect her or be sorry!

Well, there may be good reasons to elect Juanita, but you have only been given very general evidence here. Why should you take the writer's word rather than put your trust in specific details? What kinds of good things has Juanita done? How do you know that she cares about her school or her fellow students? This writer has told you very little about Juanita's accomplishments.

Now, read another paragraph with the purpose of persuading you to vote for Juanita.

Through her contributions to Peaceful High School, Juanita has earned our vote to elect her as president of the student council. Consider her work as a student representative during this past year. She began and still runs the Student Mediation Center. This student agency brings feuding students together to work out their differences through peaceful negotiations. Her work and this agency has helped reduce violence among students by 42%. Juanita also raised more than \$1500 to buy books and clothing for students at this high school who are experiencing hard times. And lastly, she helped persuade the school administration to give students a voice in making school policy. Can you think of another candidate who has done so much and who deserves more to be elected president of our student council?

After reading this paragraph, you are most likely thinking, "Wow, Juanita is quite a good candidate. Look at all her accomplishments, right here in print for everyone to see!"

As you read again the steps for building a persuasive paragraph, study the analysis of the paragraph that argues successfully for Juanita to be elected president of the student council.

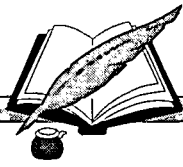

1. Before writing, determine *your purpose and audience*.

- a. Determine the opinion you want the audience to accept.

Remember: An opinion is something someone could agree or disagree with. The opinion here—elect Juanita—fits that criterion.

- b. Determine who the audience for this paragraph is. Determine what kinds of words and sentences the audience can understand.

The paragraph on Juanita was written for students just like you. The writer chose words and sentence structures which fit the reading ability of high school students. The writer also chose evidence that high school students most likely would consider important, such as reducing violence and raising money to help others buy clothes and books.

2. Construct a *topic sentence*.

- a. State the opinion the paragraph will argue for.

The topic sentence clearly states the claim the writer wants readers to accept: elect Juanita.

- b. Let the reader know how the support for your claim will be organized.

After reading the topic sentence, readers know that the paragraph will be organized according to the several contributions Juanita has made to her high school. Readers could anticipate that there will be a first contribution, another contribution, and so on.

3. List *supporting details*.

Use evidence that supports the claim that you have made in your topic sentence. Types of evidence include the following:

- definitions
- descriptions
- examples
- facts
- reasons

The types of evidence used include *examples*. All of her accomplishments are examples of how Juanita has earned votes.



These accomplishments are also reasons why students should vote for her. In addition, the writer also uses *facts*: violence has decreased by 42%; Juanita raised more than \$1500.

4. Deliver the evidence in the *right order*.
 - a. Order the evidence according to strength: the strongest first, the second strongest next, etc.

When ordering evidence, remember which audience you are writing to. What may be most important for one audience may be of lesser importance to another audience. In this case, the writer asked herself: “What is most important to students?” Because violence is the most important issue among students at Peaceful High School, the writer presented first Juanita’s work to end violence. Another important issue is how to help students buy supplies, so the writer listed Juanita’s fund raising second. Although important, making school policy is the least important issue for this particular audience.

- b. If all evidence is equally strong, use your best judgment. Try ordering the evidence in different ways, and then select the order that will best persuade readers of your claim.
5. Develop a *concluding sentence*.

- a. Restate your opinion and summarize your supporting evidence.

The author has referred to both the opinion (Juanita “deserves to be elected”) and has summarized the evidence (Juanita “has done so much”). Notice how the writer did not repeat word-for-word the opinion or evidence. Instead, she found a brief way to restate the opinion and refer to the evidence.

- b. Suggest ways in which your readers can actively support your opinion.

The writer makes it clear how readers can actively support her opinion: Vote for and elect Juanita.



Practice

Listed below are pieces of **evidence** you will use to persuade readers that taxes in your town should be raised. Next to each **audience**, write the letter of the piece of evidence that should be used first.

Audience	Evidence
_____ 1. Young professionals who are not planning on having children	A. Taxes will be used to improve schools.
_____ 2. Parents of school-aged children	B. Taxes will be used to build a senior center.
_____ 3. Parents of children not yet in school	C. Taxes will be used to improve bus service to the city's work district.
_____ 4. Senior citizens	D. Taxes will be used to build a day care center.



Making the Powerful Argument: Finding the Right Facts and Expert Testimony

In order to support your opinions in a persuasive paragraph, you must present a strong argument. A strong argument is well-organized information used to back up your opinion. The following chart lists two types of information that support strong arguments.

Supporting Information to Strengthen Arguments		
Type of Information	Definition	Possible Sources
1. Accurate Facts	Something known to be true	Encyclopedia Personal experience Almanacs Statistics Census records Research reports
2. Expert Testimony	An opinion from a reliable expert in a relevant field	University professors Professionals in a particular field, such as doctors, scientists, and researchers Eyewitnesses People with experience



Practice

Next to each **opinion** below, write the name of the best **source** in which to find support.

encyclopedia	census records	university professors
people with experience		research reports

- _____ 1. This country's population will double in size by the year 2050.
- _____ 2. Sloths are the laziest animals on the planet.
- _____ 3. Plumbers often end up with bruised bodies from crawling into tight spaces to repair pipes.
- _____ 4. College students today are more interested in political issues than ever before.
- _____ 5. Although women have made advances in the workplace, they often still are not promoted to the highest positions as often as men are.
- _____ 6. When passengers first enter a city bus driven by a woman, they often show surprise on their faces.
- _____ 7. Although most people think baseball is only a hundred years old, a game very similar to baseball was played in the Middle East over a thousand years ago.
- _____ 8. People who build quiet time into their daily routine tend to feel less overwhelmed by daily life.



Practice

Match one **expert** in the right-hand column with each **opinion** in the left-hand column. Write the correct letter on each line.

Opinion	Expert
_____ 1. Unemployment will go down as more people receive education.	A. an actress
_____ 2. The only foolproof prevention for AIDS is abstinence.	B. a doctor of infectious disease
_____ 3. Many landowners treated their slaves as though they were less than human.	C. a former slave
_____ 4. Teens need help to cope with the divorce of their parents.	D. a historian
_____ 5. It is important to dress professionally for an interview.	E. a doctor of nutrition
_____ 6. The hardest part about acting is waiting for the right part.	F. an economist
_____ 7. It is important to eat breakfast every morning.	G. an employer
_____ 8. The reason Claude Monet is so highly regarded by the art world is because his paintings perfectly illustrate the effects of light on art.	H. a professor of fine arts
_____ 9. Probably the best way to reduce cavities is to add flouride to public drinking water.	I. a dentist
_____ 10. The Vietnam War was a waste of time and money.	J. a family therapist



Practice

Read each statement below. Decide whether you would use **expository** writing or **persuasive** writing to present the topic. Write the correct answer on each line. Be prepared to defend your answers.

- _____ 1. Your best friend is the best candidate for student body president.
- _____ 2. Television increases violence.
- _____ 3. Humans need oxygen to live.
- _____ 4. The city commission should not impose an 11:00 PM curfew on teenagers.
- _____ 5. Everyone in America should vote in all local, state, and federal elections.
- _____ 6. Your school's swim team had the most improved record of any athletic team in the state.
- _____ 7. Mr. Smith is the best principal your school has ever had.
- _____ 8. Everyone has a right to health care.
- _____ 9. Wearing a seatbelt can save your life.
- _____ 10. Car racing is the most exciting spectator sport in the world.



Application

Use the form below to plan a **persuasive paragraph** on your topic from the student handbook. Then, use your own paper and write a **first draft** using your plan and your notes. Write this persuasive paragraph to an audience made up of your classmates. Select your evidence and language to fit this audience. Refer to *Building a Persuasive Paragraph* on page 120.

Before you write...

Purpose: _____ *to persuade*

Audience: _____ *my classmates*

Main Idea: _____

Topic Sentence: _____

Supporting Evidence: _____

Concluding Sentence or Statement: _____

Remember! Your argument will be more powerful if you state the specific sources of your evidence.

**Red
Alert!**

Trouble finding evidence to support an opinion?

This may be a warning sign that the opinion is not a valid one or is not based on truth. As a writer, you may need to re-evaluate your decision to support this particular opinion!

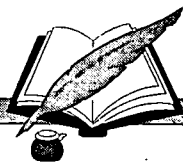

Application

Use the form below to plan a second **persuasive paragraph** on your topic from the student handbook. Then, use your own paper and write a **first draft** using your plan and your notes. Write this persuasive paragraph to an audience made up of your school's teachers and administrators. Select your evidence and language to fit this audience.

Before you write...

Purpose: to persuade

Audience: my teachers and administrators

Main Idea: _____

Topic Sentence: _____

Supporting Evidence: _____

Concluding Sentence or Statement: _____

Remember! Your argument will be more powerful if you state the specific sources of your evidence.

**Red
Alert!**

Trouble finding evidence to support an opinion?

This may be a warning sign that the opinion is not a valid one or is not based on truth. As a writer, you may need to re-evaluate your decision to support this particular opinion!

Unit 3: Writing— Taking a Second Look

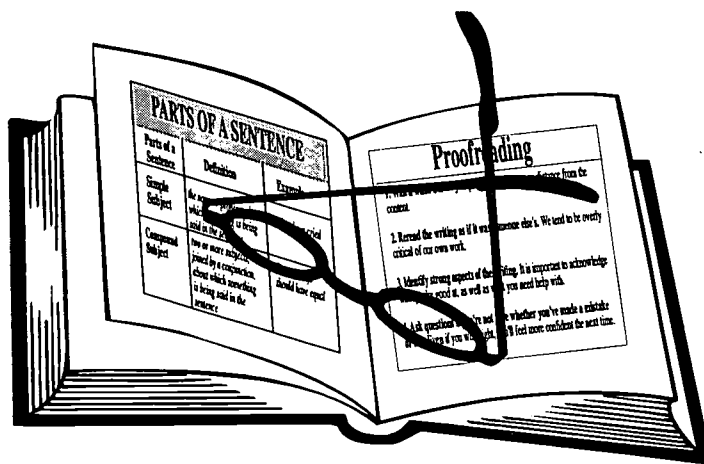

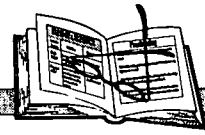

Unit 3: Writing—Taking a Second Look

Overview

In the previous unit (“Writing—Making Words Speak”) you produced two paragraphs. Although each paragraph was written to a different audience, in both paragraphs you argued for a change in your student handbook. These paragraphs are not quite finished, however. They are your first attempt to write, or “speak,” to your audiences. This first attempt to direct your writing to an audience is called a *first draft*. Think back to the last time you looked through a pair of binoculars or a microscope. Most likely, the picture you saw was a little blurred. You found, however, that by doing some fine tuning you could improve the picture until it was crystal clear. You are about to do the same thing to your first draft. You are about to fine tune your first draft so that it says exactly what you want it to say and looks exactly how you want it to look. Only after you have adjusted your paragraphs, or pictures, will your writing be ready for your readers.

The process of fine tuning your writing has three steps. The first step is called *revising*. During this step you look at what you have said and the way in which you have said it. Not until you have tuned your message are you ready for step two: *editing*. During the editing stage you check your grammar, punctuation, and spelling. Lastly, after your writing says what you intend, and uses correct English, you are ready for the final step: *proofreading*. During this step you check for typos, omitted words, misspellings, or any other “accidents” on the page. This is your final look to make sure everything is just right. When you have completed these three steps, you are ready to deliver your writing to your audience.

These three steps are used by all different levels of writers. Even professional writers don’t get it right in their very first draft. Writing is a process, and good writing has been adjusted until its message is clear, persuasive, and (nearly) error free.

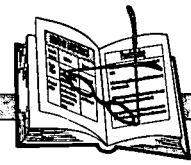

Vocabulary

Study the vocabulary words and definitions below.

- capitalization** the use of upper case letters in writing; the rules of when to capitalize a word (President **B**ill Clinton was born in Arkansas.)
- common nouns** nouns that name a general class of persons (*boys, children*), places (*playgrounds, schools*), things (*apples, bicycles*), or ideas (*love, truth*)
- complete sentence** a group of words that has a subject and verb, and that is a complete thought (*John ran. Juanita thought about the college she would attend.*)
- editing** the second step in the process of fine tuning your writing; checking the grammar, punctuation, and spelling of your writing
- noun and pronoun agreement** ... making pronouns match the noun they refer to; pronouns must match their nouns in case, gender, and number (*Juanita jumped for joy after she won her first state tennis tournament.*)
- nouns** words that name a person, place, thing, or an idea

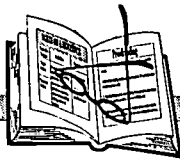

- possessives** words that show ownership or possession (*his car, her scholarship*)
- proofreading** the third step in the process of fine tuning your writing; checking for typos, omitted words, and other "accidents" on the page
- proper nouns** nouns that name specific persons (*John Steinbeck*), places (*Florida*), things (*Model T Ford*)
- punctuation** symbols or marks that help readers understand the meaning of a sentence (*Juanita asked, "John, can't you even make toast without using directions?"*)
- revising** the first step in the process of fine tuning your writing; improving the content and language of your writing
- run-on sentence** two or more sentences that are joined together without punctuation marks to separate them (*John ran to the store Juanita stayed to watch the football game.*)
- subject and verb agreement** making the verb of a sentence match its subject (*Shelby advises the doctors. Shelby and Stacy advise the doctors.*)

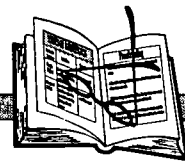

Revising: Adjusting the Picture

Revision comes from ancient words that mean “seeing again.” To revise your paragraphs, you must see and read them as if you are one of your readers, rather than the writer. Your mission is to put yourself in your readers’ place and see whether your readers will clearly understand what you’ve written. In addition, because your purpose in writing these paragraphs is to persuade your readers, you must see whether your readers will be convinced by your writing.

During the revising stage, you are checking your writing for its language, content, and organization. You are also checking to see if you have chosen the best words and composed the best sentences you can. In other words, you are checking to see if you have included the right ideas, reasons, and information. In addition, you are checking to see if you have presented the content in the right order.

Use the sets of questions below to cast a sharp light on your work. Remember: Be open to faults in your work. Few writers, even very successful ones, get it right in the first draft.

Questions for Revising a Persuasive Paragraph

Ask the following questions of your topic sentence:

1. Does your topic sentence make a claim or state an opinion that a reasonable person could disagree with?
2. Is your topic sentence clear?
3. Are any words or phrases in your topic sentence too general? Do they need to be replaced by specific words or phrases?
4. Does your topic sentence suggest the way the rest of the paragraph will be developed?

The questions for revising your topic sentence are presented again below, along with explanations and examples.

1. Does your topic sentence make a claim or state an opinion that a reasonable person could disagree with?

A good way to check this is to state the opposite of your topic sentence; then ask yourself whether a reasonable person could agree with it. Consider the following topic sentence: “We should not pollute our drinking water.” Would a reasonable person agree with the opposite claim: “We should pollute our drinking water”?

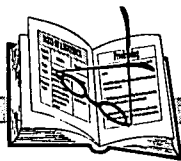

2. Is your topic sentence clear?

A good way to check this is to see whether two readers get the same meaning from your topic sentence.

3. Are any words or phrases in your topic sentence too general? Do they need to be replaced by specific words or phrases?

For example, consider the topic sentence, "Spiders should be protected, not killed, because they are good." The word *good* is very general. Seeing the word *good*, you would want to explain your meaning: "Spiders should be protected, not killed, because they *do many things that improve our homes.*"

4. Does your topic sentence suggest the way the rest of the paragraph will be developed?

Take, for example, the topic sentence, "Spiders should be protected, not killed, because they do many things that improve our homes." Note how a reader would expect the rest of the paragraph to discuss or illustrate *the many things that spiders do to improve our homes.*

Ask the following questions of each of your detail sentences:

1. Does this detail sentence support or explain the claim made in the topic sentence?
 - a. If so, how does it support or explain the topic sentence?
 - b. If not, can this detail sentence be rewritten to support or explain the topic sentence?
2. Are there any additional explanations, illustrations, or information that would help readers more clearly understand your point?
3. Are any words or phrases in your topic sentence too general? Do they need to be replaced by specific words or phrases?
4. Are your detail sentences in the best order?
5. Is a concluding sentence needed to summarize the point of your paragraph?

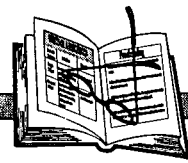

The questions for revising your detail sentences are presented again below, along with explanations and examples.

1. Does this detail sentence support or explain the claim made in the topic sentence?
Take this detail sentence and write it next to or below the topic sentence. Do you see the connection between these two sentences?
 - a. If so, how does it support or explain the topic sentence? For example, does this detail sentence offer a reason or a statistic? Be sure you can explain how each detail sentence relates to the topic sentence.
 - b. If not, can this detail sentence be rewritten to support or explain the topic sentence? If this detail sentence is not closely related to the topic sentence and cannot be revised to support the topic sentence, delete it.
2. Are there any additional explanations, illustrations, or information that would help readers be persuaded of your point?
If so, add them. One example or illustration is generally not enough to persuade readers of a claim made in a topic sentence.
3. Are any words or phrases in your detail sentences too general? Do they need to be replaced by specific words or phrases?
For example, consider the following detail sentence: "A very helpful chore that spiders do is to get rid of many bugs." Many readers would wonder *how* spiders get rid of bugs. A good rewrite would be, "A very helpful chore that spiders do is *to eat many bugs that are caught in webs.*"
4. Are your detail sentences in the best order?
Is there any information that needs to be moved up to help readers follow your discussion? If so, you will want to place them before those sentences they help clarify. If not, put the best piece of support first, the next best second, and so on. For example, consider these three detail sentences: (a) *Spiders in atypical house will keep down the number of houseflies that can be real pests.* (b) *A very helpful chore that spiders do is to eat many bugs that are caught in webs.* (c) *Spiders also snare the moths that can ruin our clothes made of wool.* These sentences are out of order. Sentence (b) explains how spiders catch these pesky insects. It should appear *before* sentences (a) and (c). Sentences (a) and (c) are examples

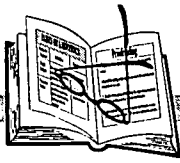

of the “many bugs that are caught in webs.” Therefore, sentences (a) and (c) should appear *after* sentence (b).

5. Is a concluding sentence needed to summarize the point of your paragraph?

If so, add it. Remember: The longer your paragraph is, the greater the need to summarize your discussion and tie your points together. Shorter paragraphs generally do not need a concluding sentence.

The paragraph below was written in favor of establishing parking spaces on campus. Its intended readers are teachers and administrators. Numbers have been inserted before each sentence for easy reference.

(1) Some students should get parking. (2) Students who are smart should get these spots. (3) If there are too many smart students, then those students who are smart and good citizens should get them. (4) It’s really amazing how many smart students there are, which is a good thing. (5) All interested students would file an application stating their grade point average and describing their contributions to the community. (6) Teachers and students should choose them. (7) Maybe these teachers and students could also choose the staff of the yearbook.

The following shows how the questions for revising a persuasive paragraph could be applied to the paragraph above.

Questions for Revising a Persuasive Paragraph

Ask the following questions of your topic sentence:

1. Does your topic sentence make a claim or state an opinion that a reasonable person *could* disagree with? (*Topic sentence: Some students should get parking.*)

Sentence (1) is the topic sentence of this paragraph. Although it does make a claim—some students should get parking spaces—it does not say why or narrow this claim in any way. The point made in sentence (2) could be included in sentence (1) to make a new and better topic sentence.

Revised topic sentence: I would like to see a few spots set aside for smart students.

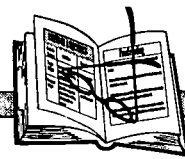

Note that a reasonable person *could* agree with the opposite claim: *I would not like to see a few spots set aside for smart students.*

2. Is your topic sentence clear? (*Topic sentence: I would like to see a few spots set aside for smart students.*)

One reader might think this sentence refers to parking spaces on campus. Another reader might not know which parking spaces this sentence refers to.

Revised topic sentence: I would like to see a few spots on campus set aside for smart students.

3. Are any words or phrases in your topic sentence too general? Do they need to be replaced by specific words or phrases? (*Revised topic sentence: I would like to see a few spots on campus set aside for smart students.*)

The phrase *smart students* is still very general. Who should be considered a “smart student”? Smart students could be defined as those students who have made the honor roll during a semester.

Revised topic sentence: I would like to see a few spots on campus set aside for students who have made the honor roll.

4. Does your topic sentence suggest the way the rest of the paragraph will be developed?

The topic sentence now suggests that the remainder of the paragraph will tell more about how students will be selected for a parking spot on campus.

The following is the sample paragraph with the revised topic sentence. Now apply the questions below to the detail sentences: sentences (2)-(6).

(1) I would like to see a few spots on campus set aside for students who have made the honor roll. (2) If there are too many smart students, then those students who are smart and good citizens should get them. (3) It’s really amazing how many smart students there are, which is a good thing. (4) All interested students would file an application stating their grade point average and describing their contributions to the community. (5) Teachers and students should choose them. (6) Maybe these teachers and students could also choose the staff of the yearbook.

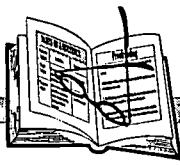

Ask the following questions of each of your detail sentences:

1. Does this detail sentence support or explain the claim made in the topic sentence?

Detail sentences (2), (4), and (5) all support or explain the topic sentence. Sentences (3) and (6) do not address the main point of the paragraph and should be deleted.

2. If so, how does it support or explain the topic sentence?

Sentence (2) suggests a good way to choose from the many honor roll students. Sentence (4) tells how students would apply for the parking spots. And sentence (5) tells who would choose from all the applicants.

3. If not, can this detail sentence be rewritten to support or explain the topic sentence?

Sentences (3) and (6) cannot be revised to fit this paragraph; they do not support or discuss the main point of the paragraph.

After deleting sentences (3) and (6), the paragraph now looks like the following:

(1) I would like to see a few spots on campus set aside for students who have made the honor roll. (2) If there are too many smart students, then those students who are smart and good citizens should get them. (3) All interested students would file an application stating their grade point average and describing their contributions to the community. (4) Teachers and students should choose them.

4. Are there any additional explanations, illustrations, or information that would help readers be persuaded of your point?

The writer of the sample paragraph can add a few points to strengthen her case. First, it would help if she explained what rule she was interested in changing. She could add the following two sentences to accomplish this:

(1) The student handbook states that no student may park his or her car in the school parking lot. (2) This rule makes sense in light of the size of the lot and the need for teachers to have a nearby parking space.

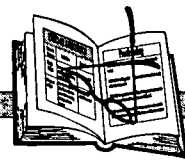

Note that sentence (1) introduces the rule that the writer is responding to. Sentence (2) shows that the writer understands why this rule was made.

5. Are any words or phrases in your detail sentences too general? Do they need to be replaced by specific words or phrases?

Yes, many words and phrases could be improved by more specific language. Below are the original detail sentences followed by a revision or comment:

(2) If there are too many smart students, then those students who are smart and good citizens should get them.

Revised detailed sentence. **Because the number of honor roll students might exceed the number of special spots, parking spaces would be given to those students who contribute to the school or city community in other ways.**

(3) All interested students would file an application stating their grade point average and describing their contributions to the community.

Sentence (3) is clear and specific as it is, so the writer has decided not to revise it.

(4) Teachers and students should choose them.

Revised detail sentence. **A special parking council made up of teachers and students would choose from the pool of applicants.**

6. Are your detail sentences in the best order? (Are there any detail sentences that help explain the others?)

The detail sentences are ordered well. They move from an explanation of the criteria to use in choosing students, to how students would apply, to who would choose from the students who apply.

7. Would a concluding sentence help to summarize your point and strengthen your case?

Yes, and here it is:

Parking spaces on campus are valuable, and that is a good reason to use a few of them to show those students who earn good grades and contribute their time that they are valued by all of us.

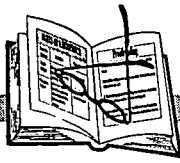

This concluding sentence gives an additional point to the writer's argument: Use the parking spaces to show students that good grades and community work are valued. It really speaks to the audience this is written for: teachers and administrators!

Now, after having written a good first draft and then doing some thoughtful revisions, the paragraph is ready to give to readers. The topic sentence has been italicized.

The student handbook states that no student may park his or her car in the school parking lot. This rule makes sense in light of the size of the lot and the need for teachers to have a nearby parking space. *However, I would like to see a few spots set aside as rewards for students who have made the honor roll.* Because the number of honor roll students might exceed the number of special spots, parking spaces would be given to those students who contribute to the school or city community in other ways. All interested students would file an application stating their grade point average and describing their community contributions. A special parking council made up of teachers and students would choose from the pool of applicants. Parking spaces on campus are valuable, and that is a good reason to use a few of them to show those students who earn good grades and contribute their time that they are valued by all of us.

Transform your paragraphs from rough minerals into sparkling diamonds by applying the questions from the charts on pages 137-138 to your drafts.

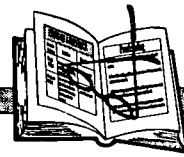

Editing: Focusing in on Grammar, Punctuation, and Spelling

When you edit your writing, you check it for any errors in grammar, **punctuation**, or spelling. Of course, before you can check your writing for errors, you must know what the rules of the English language are.

Grammar: The Way Words Work Together

Begin **editing** by checking the grammar of your writing. In this unit you will learn or review the correct way to use the following:

- sentence formation
- subject and verb agreement
- regular and irregular verbs
- singular and plural nouns
- noun and pronoun agreement
- possessives

Sentence Formation: Building Correct Sentences

Almost all of your sentences should be **complete sentences**. A complete sentence has a subject and a verb. It also must be a complete thought. Complete sentences can come in a variety of lengths. Contrast the following two complete sentences:

I am going.

I am going to the store in search of milk and eggs but not butter and sugar.

*The two most common mistakes that writers make when forming sentences are sentence fragments and **run-on sentences**. Neither the sentence fragment nor the run-on sentence are correct complete sentences.*

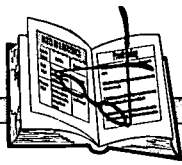

Read the following conversation.

Bill: When are you leaving?

Sarah: When Mom's ready.

Bill: Are you going to New York?

Sarah: We're going to New York, stay there for three days and then we're going to leave for Cleveland, stay there for two days and then leave for Chicago, stay there a week then we'll come home.

Bill: Well, you'll be well traveled.

Sarah: And very tired!

You may find nothing wrong with this when it is written as conversation. In fact, you have probably had conversations that used the same type of sentence structure and form. Now read the same conversation written in conventional paragraph form.

When are you leaving? When Mom's ready. Going to New York? We're going to New York, stay there for three days and then we're going to leave for Ohio, stay there for two days and then leave for Chicago, stay there a week and then we'll come home. Well, you'll be well traveled. And very tired!

Notice how the meaning gets lost when the same information is written in paragraph form and the name of the speaker is omitted. Some of the sentences seem to go on forever and others seem to be missing some information. The sentence that seems to go on forever is called a *run-on sentence*. The sentence that is missing some information or is *incomplete* is either a *sentence fragment* (for example, "And very tired!") or a *dependent clause* (for example, "When Mom's ready."). Fragments and dependent clauses cannot stand alone because they are missing important information that the reader needs to make meaning from the sentence.

Remember: A *complete sentence* expresses a complete thought. You can be sure that your sentences are complete thoughts by making sure that every sentence you write has a subject and a verb.

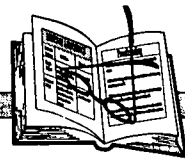

Kinds of Complete Sentences: Declarative, Exclamatory, Imperative, and Interrogative

There are four kinds of complete sentences—*declarative sentences*, *exclamatory sentences*, *imperative sentences*, and *interrogative sentences*. Each kind of complete sentence ends in a particular punctuation mark. Using these four kinds of sentences and the correct end marks adds meaning to what you are writing.

Study the types of complete sentences and their examples in the chart below.

Types of Sentences		
Sentence Type	Definition/Example	End Mark
Declarative	A sentence which makes a statement. <i>I would like to spend more time at the beach.</i>	•
Exclamatory	A sentence which expresses strong emotion. <i>Be a responsible citizen and vote!</i>	!
Imperative	A sentence which gives an order. <i>Stop killing seals!</i>	• or !
Interrogative	A sentence which asks a question. <i>When are we going to visit Atlanta?</i>	?

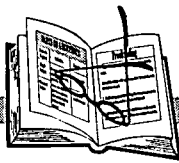

Practice

Write the missing sentences in the cartoons below. Use correct **punctuation marks**.

1. Write an interrogative sentence correctly in this cartoon.

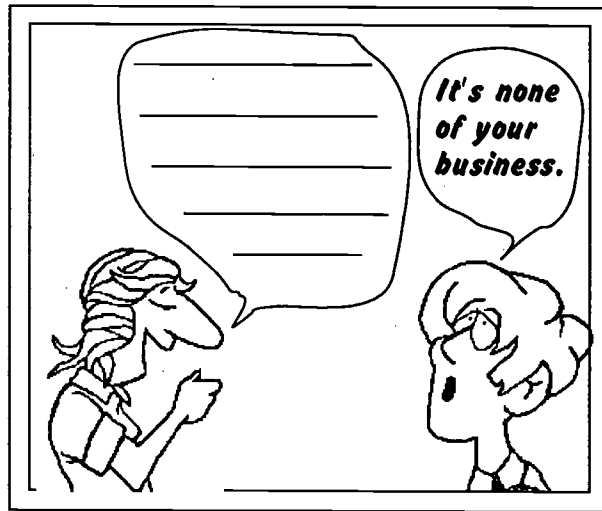

2. Write an exclamatory sentence correctly in this cartoon.

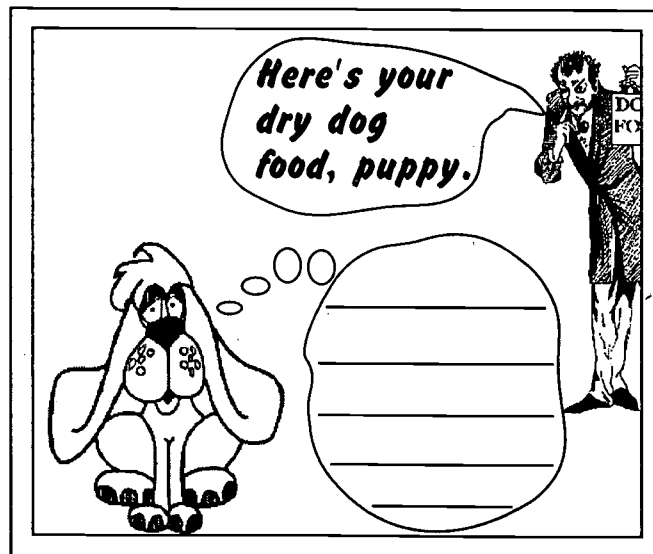

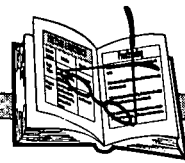

Practice

Put the correct **punctuation mark** at the end of each sentence below. Then identify the type of sentence on the line that follows.

1. She's got a loaded gun _____
2. Are you a loyal person _____
3. Please memorize your lines _____
4. I'm shocked _____
5. All citizens have the right to vote _____
6. When will the minimum wage be raised _____
7. Get lost _____
8. That suit is made in England _____
9. Who was that _____
10. Send the money immediately _____

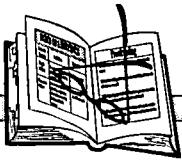

Practice

Use your own paper to complete the directions below.

1. Write five declarative sentences about your personality.
2. Write five exclamatory sentences that a person might say after seeing aliens land in his or her front yard.
3. Write five imperative sentences you would like to address to the president of the United States.
4. Write five interrogative sentences you would like to address to either a famous person or your best friend.

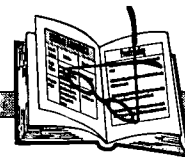

Complete and Incomplete Sentences: Finished and Unfinished Thoughts

Correcting sentence fragments is part of revising and editing. In order to correct sentence fragments you must be able to identify them and then rewrite them so they are complete thoughts. Ask yourself the following questions to help you identify and correct sentence fragments.

1. Does the sentence express a complete thought? If it does not, add the necessary words to make the thought complete.
2. Does the sentence have a subject? Do you know *who* or *what* is performing the action? If the sentence does not have a subject, insert one.
3. Does the sentence have a verb? If it does not, add one.

What's wrong with this picture?

The lady was uttering a sentence fragment because the *subject* and *verb* were missing. It should be...

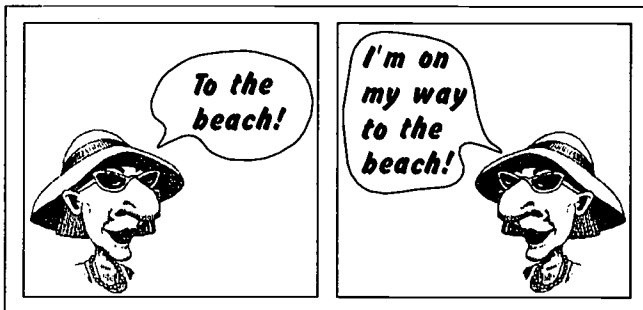

What's wrong with this picture?

The cook was uttering a sentence fragment because the *verb* was missing. It should be...

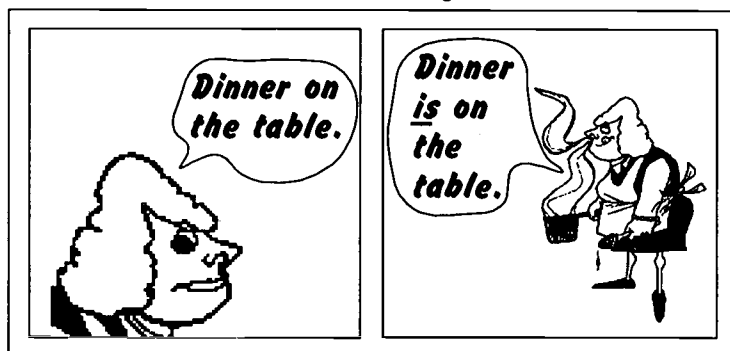

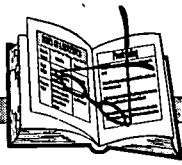

Practice

Identify the sentences below as **complete** or **incomplete**. Write **C** (complete) or **I** (incomplete) on the line that follows. If the sentence is incomplete, write **S** or **V** to show whether the sentence is missing a subject or verb.

1. Was lucky to get tickets to last night's concert. _____

2. Keyondra to the Bahamas and then to California! _____

3. Are you going to the state championship game tonight? _____

4. The state championship in the gym. _____

5. When will be ready? _____

6. Teach me to fish, and I'll fish for a lifetime. _____

7. Look around and notice the beauty of the Florida Everglades. ____

8. Alligators here! _____

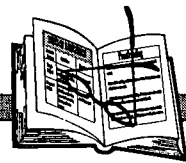

Practice

Rewrite the following **sentence fragments** into complete sentences.

1. Have gone to Mars. _____

2. My brother one of my closest friends. _____

3. Before you enter tenth grade. _____

4. As soon as they win the money. _____

5. Missed the bus. _____

6. Watched airplanes take off and land. _____

7. We under the porch hiding. _____

8. After you finish reading that book. _____

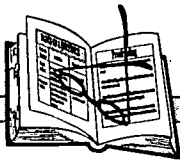

Correcting Run-on Sentences: When Words Run Stop Signs

There are four ways to correct run-on sentences. Here is an example of a run-on sentence and how it can be transformed into a complete sentence using each of the four ways.

Run-on sentence: Athletes must be smart they need their minds to be as fit as their bodies.

1. **You can make two (or more) sentences from the original run-on.** Athletes must be smart. They need to exercise their minds as well as their bodies.
2. **You can use a semicolon.** Athletes must be smart; they need to exercise their minds as well as their bodies.
3. **You can make a compound sentence using connecting words.** Athletes must be smart, so they need to exercise their minds as well as their bodies.
4. **You can make a complex sentences using independent and dependent clauses.** *Since athletes must be smart* (dependent clause), they need to exercise their minds as well as their bodies.

What's wrong with this picture?

The photographer was uttering run-on sentences. It should be...

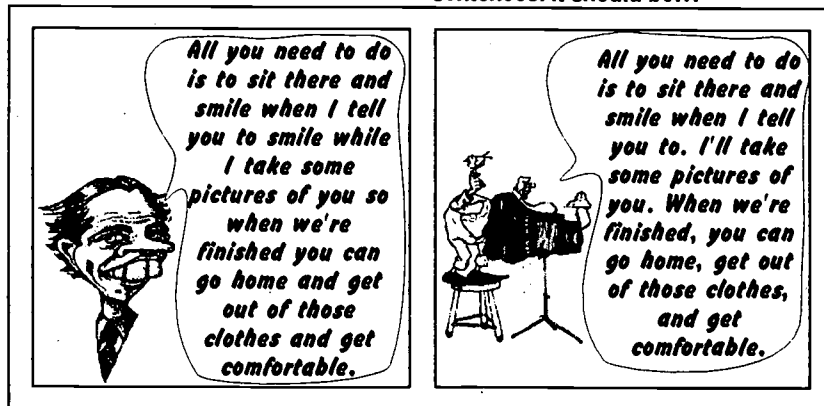

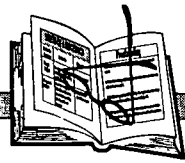

Practice

Rewrite the following run-on sentences using each of the four methods shown in the previous example.

1. I think endangered species should be protected I work to save the Florida manatee from careless boaters.

2. Young people are misrepresented by the media we should not always be portrayed as apathetic and selfish.

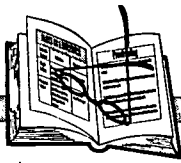

Practice

Read each sentence below. Write a **C** in front of each **complete sentence**, an **F** in front of the **sentence fragments**, and an **R** in front of each **run-on sentence**.

Remember: A complete sentence has a subject and a verb.

- _____ 1. I would love to go to Nigeria.
- _____ 2. You leaving?
- _____ 3. On Saturday, mowing the lawn.
- _____ 4. I will be a marine biologist it's the most interesting career the ocean needs help.
- _____ 5. My girlfriend is really intelligent she inspires me to do well in school.
- _____ 6. He laughed.
- _____ 7. As soon as they arrive.
- _____ 8. Last year we read *The Autobiography of Malcolm X* this year we saw the movie.
- _____ 9. Are you serious?
- _____ 10. Because you're so creative.

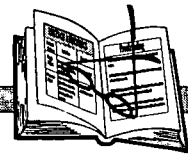

Practice

Choose one of the following **topics**. Use a separate sheet of paper and write about your chosen topic for 10 minutes.

1. pet peeves
2. strange people
3. things you wouldn't want to live without
4. the year 2050

When you have finished writing, read each sentence slowly and carefully. Answer the following questions about each sentence. If you can answer "no" to any of the questions below, the sentence is either a run-on or a fragment.

1. Does this sentence express a complete thought?
2. Does this sentence contain a verb?
3. Is it clear who or what is performing the action of the verb?
4. Does this sentence contain more than one complete thought?

Correct any run-ons or fragments by writing them as complete sentences on the lines below.

1. _____
2. _____
3. _____
4. _____

Remember! Include the appropriate punctuation mark at the end of the sentence.

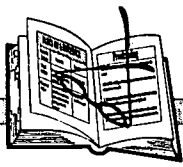

Practice

Read each question below. Circle the letter of each correct answer.

1. What is a sentence fragment?
 - a. a short sentence
 - b. a sentence in which there are too many commas
 - c. a sentence which does not express a complete thought
 - d. an exclamatory sentence

2. Which of the following problems does not indicate a sentence fragment?
 - a. no subject
 - b. no verb
 - c. spelling mistakes
 - d. an incomplete thought

3. Which one of the following methods would not correct a run-on sentence?
 - a. Break the run-on sentence into two or more sentences.
 - b. Add another subject and verb so that the run-on sentence expresses a complete thought.
 - c. Use a semicolon.
 - d. Make the run-on sentence into a compound sentence using connecting words.

4. What kind of sentence is this? *I am proud to be a woman.*
 - a. a sentence fragment
 - b. a run-on sentence
 - c. a complete sentence
 - d. an interrogative sentence

5. What kind of sentence is this? *Read carefully!*
 - a. an exclamatory sentence
 - b. an interrogative sentence
 - c. a declarative sentence
 - d. an imperative sentence

272

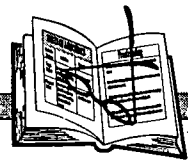

6. What punctuation mark always appears at the end of an interrogative sentence?
 - a. .
 - b. !
 - c. ;
 - d. ?

7. Could a complete sentence contain only two words?
 - a. Yes, if they are a subject and a verb.
 - b. No, never.
 - c. Yes, but only if it is an interrogative sentence.
 - d. Yes, if the first word is capitalized and the sentence has no punctuation.

8. Which sentence below is not an imperative sentence?
 - a. Are you crazy?
 - b. Go to your room!
 - c. Listen to me!
 - d. Speak up, please.

9. "Ran away." is an example of a
 - a. complete sentence.
 - b. sentence fragment.
 - c. run-on sentence.
 - d. declarative sentence.

10. "Jan ate a frog." is an example of a
 - a. complete sentence.
 - b. sentence fragment.
 - c. run-on sentence.
 - d. declarative sentence.

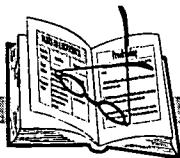

Subject and Verb Agreement: Matching the Doer and Its Action

Most of us learn to speak English by copying what we hear our parents say. Because you learn to speak from listening to your parents or others, you might find yourself using words or phrases that others don't completely understand.

In many parts of the country, people speak in their local *dialect*, which is the language of a particular area. If you lived in Rhode Island and ordered a cabinet and a grinder, you would get the same thing that someone in Missouri would get if they ordered a milkshake and a hoagie. Some people in Mississippi do not pronounce the "l" in the word *Gulf* so it sounds like it rhymes with "cuff."

A local dialect might include mismatching the subject and verb of a sentence. You might have heard someone say, "*They was tired*," instead of "*They were tired*," or "*She don't know*," instead of "*She doesn't know*." In order to make sure that your audience understands what you are saying, it is important to use language that will not be misunderstood by your readers.

One way you can make sure that what you are writing is not misunderstood by your audience is to follow the rule of **subject and verb agreement**. It may be obvious to you that nouns or subjects can be singular and plural. *Dog* is singular and *dogs* is plural. Verbs can also be singular or plural. *Was* is singular and *were* is plural. If you think about it, *Helen were here*, sounds strange. This is because *Helen* is singular, but *were* is plural, and if the subject is singular, the verb should be too. If the subject is plural, the verb should be plural also. This is known as *subject/verb agreement*.

In some sentences, you may find it difficult to tell if a subject is singular or plural, which in turn makes it difficult to make the verb agree. For example, take the following sentence:

An answer to your letters is finally here.

Is the subject the singular noun *answer* or the plural noun *letters*? The subject is *answer*. It is an answer—not the letters that is finally here. Do not let the phrase or clause between the subject (an answer) and its verb (is) confuse you. In this example, the phrase to your letters simply

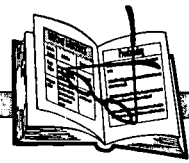

modifies or describes an answer. What is the subject in the following example?

Books in the library are arranged by subject.

The subject is the plural noun *books*. It is the books *not* the library that are arranged by subject. In this example, the phrase in the library simply modifies or describes books.

It is fairly easy to determine that pronouns such as *I*, *he*, and *she* are singular, but what about the pronouns *anyone* or *few*? Study and remember the following rules about pronouns.

1. A phrase that follows a subject does not change the number of the subject.
2. The following are singular pronouns and require singular verbs: *each*, *either*, *neither*, *one*, *no one*, *everybody*, *someone*, *anyone*, *everyone*, *nobody*, *somebody*, *everything*, and *anything*.
3. The following are plural pronouns and require plural verbs: *several*, *many*, *both*, and *few*.
4. The following are singular *or* plural pronouns depending on the sentence: *some*, *all*, *most*, *any*, and *none*.

If these words refer to a singular noun, then they are also singular. For example—**Some** of the **pie** *was* still frozen.

If the words refer to a plural noun, then they are also plural. For example—**Some** of the **birds** *were* captured.

The 'S' Rule

Most **verbs** ending in an *s* are **singular**.
Most **nouns** ending in an *s* are **plural**.

Therefore, if your *subject* and *verb* **both end in s** or **neither ends in s**, you should **check their agreement**.

Singular noun—no s	Singular verb—with s
1. The girl understands.	
2. The girls understand.	
Plural noun—with s	Plural verb—no s

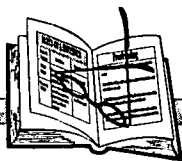

Practice

*In the sentences below, circle the **verb** that agrees with the **subject**. (Remember the 's' rule!)*

1. Iguanas (creeps, creep) along the ground.
2. The king (believes, believe) in beheading.
3. Black holes (swallows, swallow) everything in their path.
4. What we're looking for (is, are) justice.
5. Fred and Barney (sings, sing) out of tune.
6. Most of us (refrains, refrain) from being violent.
7. Why (doesn't, don't) we get married?
8. Landfill sites (expands, expand) extremely quickly.
9. (Has, Have) the police officer and the suspect been interviewed by the press?
10. We (was, were) completely happy in the 1990s.

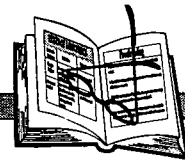

Practice

*In the sentences below, circle the **subject** that agrees with the **verb**.*

1. The (trash cans, trash can) needs to be repaired.
2. (They, He) was exercising every day.
3. I hope my (shoe, shoes) were borrowed rather than stolen.
4. (They, she) don't enjoy fighting dragons.
5. You must know that (an umbrella, umbrellas) is a necessity in Seattle.
6. The (twin, twins) like you.
7. The French (word, words) means "to smile."
8. (They, He) sharpen the pencils daily.
9. (An apple, Apples) taste delicious with chocolate.
10. He believes his (wig, wigs) flatters him.

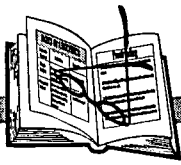

Practice

Circle the **subject**, and underline the correct **verb** in each sentence below. Study the examples of the four special cases described on p. 161 before you begin.

Example: The number of women in the military (has, have) increased over the last decade.

1. A large basket of toys (was, were) found on your doorstep.
2. Everyone (wonders, wonder) if love is really blind.
3. Both cars (is, are) valuable.
4. Some trolls (lives, live) under bridges.
5. Some of the goats from the farm (is, are) afraid to cross the bridge.
6. My power to vanish and reappear (is, are) useful when I'm on a date.
7. Everybody (looks, look) different after a ride on a roller coaster.
8. Few of the rappers (believes, believe) that rap could have evolved without jazz or blues.
9. Most of the country (votes, vote).
10. I think most of the voters (wishes, wish) campaigns were more truthful.
11. The solution to violence, greed, and ignorance (is, are) education.
12. Each young person (has, have) a lot of power in the market place.
13. Several baseball players (speaks, speak) about the pressures of the game.
14. All the money in the world (does, do) not make a person happy.
15. All the people (thinks, think) money can buy happiness.

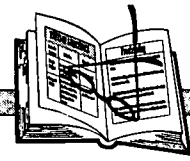

Regular and Irregular Verbs: Hard Working Words

Verbs are amazing words. Not only do they tell what the action is in a sentence, they also tell when the action happened. The action of a sentence can happen in the past, in the present, or in the future. These time frames are called the *tense* of a verb.

Verbs have four principle tenses.

Present	Present Participle	Past	Past Participle
laugh	laughing	laughed	have laughed
shout	shouting	shouted	have shouted
love	loving	loved	have loved

All the verbs above are regular. The past tense of a regular verb is made by adding *-ed* to the basic form. The past participle of a verb is made by adding *-ed* to the verb itself and then pairing it up with "have," "has," or "had."

Some verbs are **irregular verbs** and do not follow this rule. The best way to learn how to spell irregular verbs is to memorize them. Study the following chart of irregular verbs.

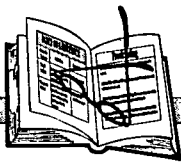

Principal Parts of Irregular Verbs

Present	Past	Past Participle	Present	Past	Past Participle
be	was	been	lose	lost	lost
become	became	become	make	made	made
begin	began	begun	mean	meant	meant
blow	blew	blown	meet	met	met
break	broke	broken	pay	paid	paid
bring	brought	brought	put	put	put
buy	bought	bought	read	read	read
catch	caught	caught	ride	rode	ridden
come	came	come	ring	rang	rung
cost	cost	cost	run	ran	run
cut	cut	cut	say	said	said
do	did	done	see	saw	seen
drink	drank	drunk	sell	sold	sold
drive	drove	driven	send	sent	sent
eat	ate	eaten	shake	shook	shaken
fall	fell	fallen	shoot	shot	shot
feel	felt	felt	shut	shut	shut
fight	fought	fought	sing	sang	sung
find	found	found	sit	sat	sat
fly	flew	flown	sleep	slept	slept
forget	forgot	forgotten	speak	spoke	spoken
get	got	gotten	spend	spent	spent
give	gave	given	stand	stood	stood
go	went	gone	steal	stole	stolen
grow	grew	grown	sweep	swept	swept
have	had	had	take	took	taken
hear	heard	heard	teach	taught	taught
hit	hit	hit	tell	told	told
hold	held	held	think	thought	thought
hurt	hurt	hurt	throw	threw	thrown
keep	kept	kept	understand	understood	understood
know	knew	known	wear	wore	worn
leave	left	left	win	won	won
lend	lent	lent	write	wrote	written

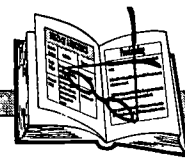

Practice

Write the correct form of each **irregular verb** on the lines provided.

- | | | |
|-----------------------|-----------------------------------|------------------------------|
| 1. Now I bring | Yesterday I <u><i>brought</i></u> | I have <u><i>brought</i></u> |
| 2. Now I buy | Yesterday I _____ | I have _____ |
| 3. Now I catch | Yesterday I _____ | I have _____ |
| 4. Now it costs | Yesterday it _____ | It has _____ |
| 5. Now I cut | Yesterday I _____ | I have _____ |
| 6. Now I find | Yesterday I _____ | I have _____ |
| 7. Now I hear | Yesterday I _____ | I have _____ |
| 8. Now I hold | Yesterday I _____ | I have _____ |
| 9. Now I hurt | Yesterday I _____ | I have _____ |
| 10. Now I leave | Yesterday I _____ | I have _____ |
| 11. Now I lend | Yesterday I _____ | I have _____ |
| 12. Now I lose | Yesterday I _____ | I have _____ |
| 13. Now I sweep | Yesterday I _____ | I have _____ |
| 14. Now I tell | Yesterday I _____ | I have _____ |
| 15. Now I teach | Yesterday I _____ | I have _____ |
| 16. Now I understand | Yesterday I _____ | I have _____ |

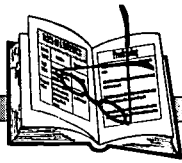

Practice

Fill in the blanks with the correct verb form.

	Present	Past	Past Participle
1.	become	_____	_____
2.	_____	came	_____
3.	_____	_____	begun
4.	do	_____	_____
5.	_____	flew	_____
6.	_____	_____	grown
7.	know	_____	_____
8.	_____	rode	_____
9.	_____	_____	seen
10.	shake	_____	_____
11.	_____	_____	read
12.	_____	stole	_____
13.	throw	_____	_____
14.	_____	wore	_____
15.	_____	_____	written
16.	take	_____	_____
17.	_____	_____	sung
18.	teach	_____	_____
19.	_____	shook	_____
20.	speak	_____	_____

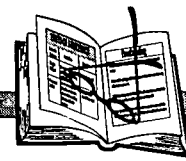

Practice

Circle the errors in verb tense in the sentences below. Rewrite the paragraph correctly.

I first became aware that something was odd about him when he step from his spaceship. He told me he had rode his spaceship to Earth from another galaxy. At first I did not believe him. I begun to get suspicious when he drunk soda and eat pizza like a pro. After he had eat, he asked for a muffin for dessert. I think for sure he was just an earthling on a highly secret Air Force mission. But then he boarded his spaceship and fly away at warp speed. It was not until I seen him disappear in a flash that I realized I had just spent an evening with an alien.

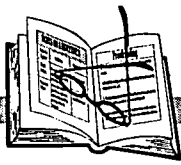

Nouns: Plural or Singular?

Nouns are words that name people, places, things, or ideas. Writers must use nouns to describe the details of lives as well as the hopes, fears, and ideals of generations. **Common nouns** name any one of a group of persons, places, or things. **Proper nouns** name a particular person, place, or thing.

Read this sentence that includes common nouns.

While riding on the city bus, the woman was reading a good book.

Read the same sentence in which the common nouns have been replaced with proper nouns.

While riding on the Toronto bus, Gloria Schitzel was reading *101 Ways to Give Your Plants a Happy Life*.

Compound nouns are made up of two or more words joined together. The words may be hyphenated, joined together, or written separately. *Self-sufficient, mother-in-law, high jump, cable television, and broomstick* are all compound nouns.

Collective nouns are singular nouns that name a group, things, or people. *Cluster, family, harem, gang, and class* are all collective nouns.

All of these nouns—common, proper, compound, and collective—can be singular or plural. Plurals are formed in various ways. Typically, we add *s* or *es* to the ends of nouns to make them plural. However, some plurals are formed by changing the spelling of the noun, while still others may remain exactly the same as the singular form. Study the chart on the following page on the rules for forming plurals.

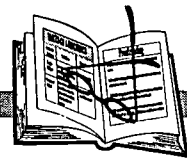

Rules of Pluralization

To make a noun plural...

add <i>s</i> to most nouns.	<i>car</i>	<i>cars</i>
add <i>es</i> to nouns ending in <i>s</i> , <i>sh</i> , <i>ch</i> , <i>x</i> , and <i>z</i> .	<i>branch</i>	<i>branches</i>
change the <i>y</i> to <i>i</i> and add <i>es</i> to nouns ending in a consonant followed by a <i>y</i> .	<i>pony</i>	<i>ponies</i>
add <i>s</i> to nouns ending in a vowel followed by a <i>y</i> .	<i>boy</i>	<i>boys</i>
change the <i>f</i> to <i>v</i> and add <i>es</i> to nouns ending in <i>f</i> or <i>fe</i> .	<i>knife</i>	<i>knives</i>
add <i>s</i> to nouns ending in <i>f</i> .	<i>chief</i>	<i>chiefs</i>
add <i>s</i> to nouns ending in a vowel followed by <i>o</i> .	<i>rodeo</i>	<i>rodeos</i>
add <i>es</i> to nouns ending in a consonant followed by <i>o</i> .	<i>tomato</i>	<i>tomatoes</i>
change the basic spelling of certain words.	<i>ox</i>	<i>oxen</i>
spell certain words the same way in singular and plural form.	<i>deer</i>	<i>deer</i>
add <i>'s</i> to letters, numbers, and signs.	<i>p</i>	<i>p's</i>
add <i>s</i> or <i>es</i> following appropriate rules, if the number is spelled out.	<i>three</i>	<i>threes</i>
add <i>s</i> or <i>es</i> to compound nouns to make compound nouns plural.	<i>leftover</i> <i>eyelash</i>	<i>leftovers</i> <i>eyelashes</i>
add <i>s</i> to the noun and leave the modifier in hyphenated compound nouns unchanged.	<i>son-in-law</i>	<i>sons-in-law</i>

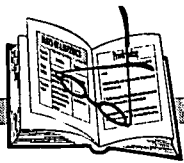

Practice

Write the plural form of the following nouns.

- | | |
|------------------|-------------------------|
| 1. tree _____ | 16. background _____ |
| 2. fish _____ | 17. 6 _____ |
| 3. ruby _____ | 18. person _____ |
| 4. toy _____ | 19. mouse _____ |
| 5. life _____ | 20. family _____ |
| 6. reef _____ | 21. lady _____ |
| 7. radio _____ | 22. D _____ |
| 8. tornado _____ | 23. torpedo _____ |
| 9. child _____ | 24. mother-in-law _____ |
| 10. sheep _____ | 25. Susan _____ |
| 11. 1960 _____ | 26. class _____ |
| 12. two _____ | 27. hope _____ |
| 13. sack _____ | 28. belief _____ |
| 14. dish _____ | 29. smile _____ |
| 15. wife _____ | 30. ditch _____ |

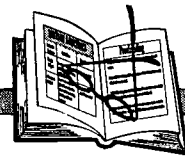

Practice

Explorers bring back a language workbook from a distant planet called Xacton. Unfortunately, several pages had been destroyed. Fortunately, the Xactonians use the same pluralization rules we use. Apply our rules from the chart on page 171 to the following Xactonian singular nouns. Write the plural forms on the lines below.

Singular		Plural
1. one blurd	many	_____
2. one shnix	many	_____
3. one croy	many	_____
4. one vixife	many	_____
5. one seo	many	_____
6. one jehno	many	_____
7. one ux	many	_____
8. one gluchny	many	_____
9. one thran-in-law	many	_____
10. one noilo	many	_____

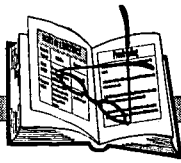

Practice

Write the **singular** form of each of the following nouns.

- | | | | |
|---------------|-------|--------------|-------|
| 1. boxes | _____ | 15. papers | _____ |
| 2. cats | _____ | 16. elves | _____ |
| 3. ponies | _____ | 17. beaches | _____ |
| 4. brushes | _____ | 18. bodies | _____ |
| 5. dairies | _____ | 19. inches | _____ |
| 6. dresses | _____ | 20. chains | _____ |
| 7. assemblies | _____ | 21. shirts | _____ |
| 8. lives | _____ | 22. bottles | _____ |
| 9. geese | _____ | 23. flowers | _____ |
| 10. calves | _____ | 24. waxes | _____ |
| 11. bases | _____ | 25. states | _____ |
| 12. files | _____ | 26. picks | _____ |
| 13. beads | _____ | 27. books | _____ |
| 14. bikes | _____ | 28. concerts | _____ |

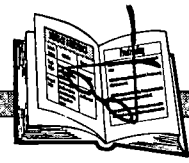

- | | |
|---------------------|----------------------|
| 29. buddies _____ | 40. messes _____ |
| 30. planes _____ | 41. switches _____ |
| 31. ears _____ | 42. activities _____ |
| 32. cities _____ | 43. skates _____ |
| 33. trails _____ | 44. years _____ |
| 34. faces _____ | 45. teams _____ |
| 35. agencies _____ | 46. changes _____ |
| 36. witnesses _____ | 47. seconds _____ |
| 37. leaves _____ | 48. wings _____ |
| 38. lies _____ | 49. cries _____ |
| 39. witches _____ | 50. strikes _____ |



Practice

Fill in the blanks with the correct **singular** form of the noun in parentheses.

1. The _____ (men) was lost.
2. He asked a young _____ (children) for directions.
3. She was not familiar with the _____ (cities).
4. In desperation he flagged down a _____ (buses).
5. The driver gave him a _____ (maps).
6. It showed him that the street was named after a famous _____ (people).
7. He found the street and entered the _____ (galleries).
8. He was looking for a painting of a mysterious _____ (women).
9. It was located next to a sculpture of a _____ (deer).
10. He looked at the painting and realized that the mystery portrait was of his _____ (sisters-in-law).

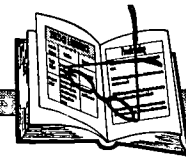

Practice

Fill in the blanks with the correct **plural** form of the word given in parentheses.

1. Quickly he phoned several _____ (art historian) and told them about her identity.
2. They wrote down her name and both of her _____ (address).
3. She admitted that she had posed for the artist in the _____ (1950).
4. The artist had admired the tattoo of entwined _____ (fish) on her left shoulder.
5. She didn't like the painting and it was against her _____ (wish) to be identified with it.
6. It was too late: _____ (radio) all over the country were announcing the discovery.
7. One night she entered the gallery with several sharp _____ (knife).
8. She cut the painting into two _____ (half).
9. _____ (Century) later, the painting became known as "The Divided Woman."

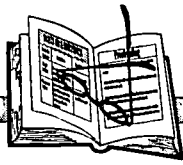

Noun and Pronoun Agreement: Drawing a Strong Link

A pronoun is a word that stands in for a noun. Consider the following examples:

- (a) The *student* wished *she* had studied harder for the exam.
- (b) The *students* wished *they* had studied harder for the exam.

In sentence (a), the word *she* is a pronoun. It stands in for the noun, *student*. Note that because the noun (*student*) is singular, the pronoun (*she*) also must be singular. In sentence (b), the word *they* is a pronoun. It stands in for the noun, *students*. Similarly, because the noun (*students*) in this sentence is plural, the pronoun (*they*) also must be plural. The noun to which a pronoun refers is called an *antecedent*. In the examples above, the antecedents are *student* and *students*. Wherever you use a noun (antecedent) and pronoun, they must match. This is called *noun and pronoun agreement*.

Imagine as you are reading, you find this sentence: “The *students* wished *she* had studied harder for the exam.” You would be left to wonder where the *she* in this sentence came from or where *she* belongs. You would know *she* is not the students—after all there are many *students* but only one *she*. So, as you can see, when a noun and pronoun do not agree, the reader is left, well, in a disagreeable state!

Pronouns must match their antecedents in case, gender, and number.

Case refers to the way a pronoun is used in a sentence.

- A pronoun can be used as a subject:

He is able to do nine things at once, but not ten things.

- A pronoun can be used as an object:

Don't ask *him* to do ten things at once.

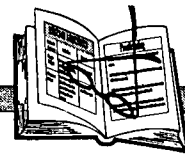

- A pronoun can be used as a possessive:

His ability to do nine things at once is remarkable!

Gender refers to the sexual category of a noun or proper noun.

- Pronouns that refer to masculine antecedents must also be masculine:

Joe can do nine things at a time. *He* cannot, however, do ten things at once.

The *boy* will always know you care for *him*.

Joe knows *he* can do the job well.

- Pronouns that refer to feminine antecedents must also be feminine:

Gina is one of the finest thinkers in the state. *She* understands how ideas work.

The *girl* will always carry your smile with *her*.

Gina knows *she* is a good thinker.

- Pronouns that refer to antecedents of neither sex must also be neuter:

The *dog* is feisty. *It* can play all day.

The *cat* knows *its* place when the dog is nearby.

Number refers to whether the noun is singular (for example, *the boy* or *the table*) or plural (for example, *the boys* or *the tables*).

- Pronouns that refer to singular antecedents must also be singular:

Take the *exam* and do *it* at home.

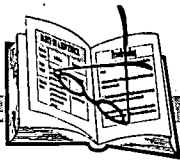

- Pronouns that refer to plural antecedents must also be plural:

Take the *exams* and do *them* at home.

- Some words seem to be both singular and plural. They are *each, either, neither, one, everyone, everybody, no one, nobody, anyone, anybody, someone, and somebody*. When referring to these antecedents, use a singular pronoun: *he, him, his, she, her, hers, it, its*.

Each person needs a challenge *he* can overcome.

Everybody should bring a book *she* can share with the class.

- When two singular antecedents are joined by *or* or *nor*, the pronoun should be singular.

Either Alice *or* Mary will read a poem *she* has written.

Neither John *nor* Fernando can find a sweater *he* likes.

- When two or more antecedents are joined by *and*, the pronoun should be plural.

Alice *and* Fernando know *they* have a lot of studying to do before the exam.

Gina *and* Mary can't come to the party. *They* have an exam the next morning.

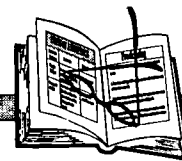

Practice

Replace each **noun**, **proper noun**, or **question mark (?)** that is in parentheses with the correct **pronoun**. Write your answers above the parentheses. The first one has been done for you.

1. Alicia is the finest field goal kicker in the state. (*She*) has won the high school kicking contest three years in row.
2. The boys in our school marvel at how far and straight Alicia can kick a football. (The boys) think Alicia has a stronger leg than any male kicker they have ever seen.
3. John often tries to help everyone. (John) often finds himself stretched thin and too short on time.
4. The test is much easier than I expected. (The test) may only seem so easy because I studied so hard.
5. Joe and Shannon are the best of friends. (Joe and Shannon) often say the same thing at the same time.
6. This high school has the best program for students who want to be electricians. (This high school) has a building on which future electricians can practice the trade.
7. Everybody needs to discover what (?) wants to do as a career for the next thirty or forty years.
8. Tim is one helpful fellow. (Tim) often does me a favor before I even ask for one.
9. The cat has scratched a hole in this wall. Imagine, (this cat) has scratched through a brick wall!
10. Anyone can learn to watch less television if (?) truly has a desire to become more productive.

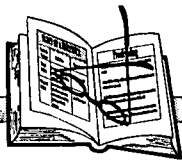

Possessives: Showing Ownership

Possessives are used to show that one person or thing owns something. For example, the clause, *That is the girl's dog*, shows that the dog is owned by the girl. Possessives are also used to show the relationship between one thing and another. For example, the question, *Who is performing on today's program?*, asks a question about the program that is being presented today. Possessives are shown by an apostrophe and an *s*, or in some cases, by just adding an apostrophe:

the boy's bicycle (one boy)

the boys' bicycles (more than one boy)

the children's toy box (children)

the ladies' race car (more than one lady)

In most cases, it is easy to tell whether a word should be made possessive, as in the examples above. However, some cases are more difficult. Would you add an apostrophe to the word *days* in the phrase *a days work*? If you are uncertain, simply rewrite the phrase using the word *of*: *the work of a day*. If the *of* fits, then use an apostrophe: *a day's work*.

Study the rules for forming possessives in the chart below.

Rules for Forming Possessives	
▶ To form the possessive of a singular noun, simply add an <i>apostrophe</i> and an <i>s</i> .	
the notebook that belongs to Brita	➔ Brita's notebook
the cat that belongs to the boy	➔ the boy's cat
the eyes that belong to the monster	➔ the monster's eyes
▶ To form the possessive of a plural noun ending in <i>s</i> , simply add an <i>apostrophe</i> .	
the manes that belong to the horses	➔ the horses' manes
the discoveries that belong to the students	➔ the students' discoveries
▶ To form the possessive of a plural noun that does not end in <i>s</i> , simply add an apostrophe and an <i>s</i> .	
the clubhouse that belongs to the children	➔ the children's clubhouse
the antiques that belong to the men	➔ the men's antiques

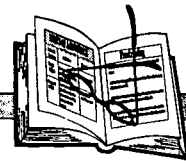

Pronouns present a special case. The possessive case of a pronoun is not formed by adding an apostrophe or an s.

Pronoun	----->	Possessive
I	----->	my, mine
you	----->	your, yours
he	----->	his
she	----->	her, hers
it	----->	its (<i>not it's, which means it is</i>)
we	----->	our, ours
they	----->	their, theirs
who	----->	whose

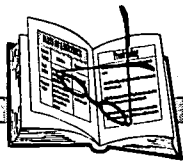

Practice

Change each **phrase** that is in parentheses into a **possessive**. Write the possessive above the phrase in parentheses. The first one has been done for you.

girl's sandwich

1. The (*girl's sandwich* that belongs to the girl) was eaten by her very hungry dog.
2. The (pages of the book) were beginning to yellow and disintegrate.
3. The (model airplanes that belong to the boys) were exact replicas of World War II bombers.
4. Many experts thought the (toys that belong to the girl) were from the nineteenth century.
5. The (sandbox that belongs to the children) has almost no sand left in it.
6. The (tails that belong to the cats) stuck straight up in the air as the cats paraded down the street.
7. The (tools that belong to the women) had been passed down through four generations.
8. The (absences that belong to the student) were finally explained when the (story that belonged to the student) appeared in the local newspaper.
9. Talk about the (adventures that belonged to the student) filled the (hallways that belonged to the school) for three weeks.
10. The (laughter that belonged to the townspeople) could be heard until sunrise.
11. (The car that belongs to me) has never been repaired—or driven!
12. (The house that belongs to them) leans to the left on some days, and to the right on other days.

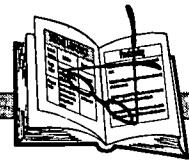

13. (The house that belongs to us), however, does not lean to either side—it just keeps disappearing into this sinkhole!
14. (The house that belongs to him) is particularly mysterious because it keeps rising higher and higher off the ground.
15. (The doghouse that belongs to it) is also a marvel—it slowly rotates while the dog is inside it.

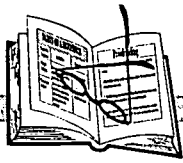

Capitalization: Upper Case Rules

Capitalization means using "upper case or capital letters." Capital letters are used for two main reasons. First, they are used to signal the beginning of a sentence. Second, they are used to signal words we consider particularly important. Study the chart below for the rules of capitalization.

Always capitalize...	
the first word of every sentence.	The coffee grounds were in my cup.
a person's name and any initials.	John F. Kennedy
titles of people.	Dr. Jones, Mrs. Fisher
I and O when they are used as words.	It's the duck that I saw. "Exult O shores! and ring O bells!"
days of the week, and months of the year.	Tuesday, March
religions, creeds, denominations, names applied to the Bible and its parts, other sacred books, and nouns and pronouns referring to a deity.	Christianity, Old Testament, God, the Almighty
countries, nationalities, races, and languages.	Spain, Spaniards, Spanish, Spanish rice
names of specific cities, states, avenues, streets, routes, and other geographical and place names.	North America, Atlanta, Chicago, Route 66
names of special organizations—government, businesses, schools, professional, and social.	Amtrak, the Jaycees, Sears, Sandalwood High School
names of special buildings and other man-made structures, ships, and planes.	Southpoint Mall, the <i>Titanic</i> , the Gulf Life Building
brand or trade names.	Goodyear tires, Kleenex, General Electric
holidays, special or famous events, historical periods or eras, and famous documents.	Labor Day, the Boston Tea Party, the Gold Rush, the Declaration of Independence
the first word and all important words in the title of a book, magazine, movie, television show, and songs.	<i>Family Circle</i> , <i>Home Alone</i> , <i>General Hospital</i> , <i>America</i> , <i>the Beautiful</i>
words that come from names that are capitalized.	San Francisco, San Franciscan
the first word of quoted sentences.	Tom said, "We won the game!"

Rules of Capitalization

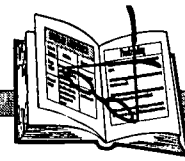

Do not capitalize...

More Rules of Capitalization

the name of a school subject, unless it is the name of a specific course or language.	My favorite science course is Biology 101. Sue made low grades in algebra and history.
the names of seasons or directions.	The flowers are lovely in the spring. Turn west after you pass the bank.
the name of trees, fruits, vegetables, birds, or flowers.	roses, robins, oak, mahogany, corn
the names of games or sports, unless the name is a trademark.	Tables were arranged for checkers, Scrabble™, Monopoly™, bridge, and dominoes. Our football team went to see the Redskins in the playoff.
the name of a disease, unless it is named for a person, and then do not capitalize the word <i>disease</i> .	measles, pneumonia, Hodgkin's disease
the names of musical instruments.	violin, drums, Baldwin™ piano

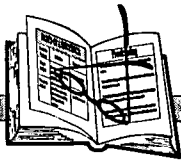

Practice

Rewrite all the words that should be capitalized, using appropriate capital letters.

1. gainsville _____
2. sister _____
3. tammy _____
4. canada _____
5. ny giants _____
6. silver _____
7. malcolm _____
8. j. c. penney _____
9. dairy queen _____
10. school _____
11. holiday _____
12. easter _____

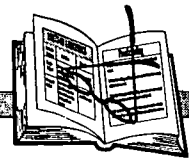

13. january

14. lion

15. dr. chin

16. avenue

17. spanish

18. muslim

19. tampa

20. elm street

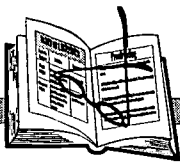

Practice

Read the paragraph below. Circle each letter that should be **capitalized**.

maya angelou is a famous african-american poet. she grew up in arkansas, which is in the southern part of the united states. her poetry and writing contain images from her black southern heritage. ms. angelou says in her book *i know why the caged bird sings* that william shakespeare was her first white love. today, both shakespeare and angelou are taught in english classes. in 1975, maya angelou received the *ladies' home journal* "woman of the year" award. she has also received honorary degrees from many universities, including wake forest university. she also wrote a poem that was read at the inauguration of president clinton.

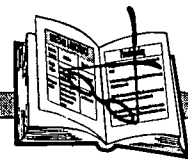

Punctuation: Roadsigns to Guide Readers

A good way to think of **punctuation** marks is to imagine them as roadsigns along a sentence. As the reader travels down the sentence, he or she needs signs to make sense of your writing. Where should the reader stop, or pause, or read your sentence as a question rather than as a command?

We use punctuation to help make our writing clearer and easier to understand. Read the examples below.

If John bakes Fred will clean up the kitchen.

Now look at this sentence.

If John bakes, Fred will clean up the kitchen.

Can you see the difference that one comma makes? Did *John bake Fred*? Or did *John bake and Fred clean up*? Without the comma in the second example, the reader might think that Fred was going to be tonight's dessert. Commas and other punctuation marks help the reader understand what is written.

Study the "Rules of Punctuation" on the following page.

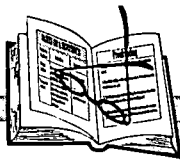

Rules of Punctuation

Punctuation Mark	Rules	Examples
Apostrophe ’	<ol style="list-style-type: none"> 1. Apostrophes are used to show possession, or ownership. 2. Apostrophes are used to form contractions (they go where the missing letter would have been). 3. Apostrophes are used to form plurals of letters, numbers, and symbols. 	Joel’s sneakers women’s clothes it’s can’t you’ve p’s and q’s
Quotation Marks “ ”	<ol style="list-style-type: none"> 1. Quotation marks are used to show the beginning and end of a direct quotation or a person’s exact words. 2. Quotation marks are used to enclose the titles of magazine articles, chapters, short stories, essays, poems, and short pieces of music. 	“You can learn punctuation,” said the teacher. “The Masque of the Red Death” “The Enemy” “Stairway to Heaven”
Comma ,	<ol style="list-style-type: none"> 1. Commas are used to separate items in a series. 2. Commas are used to separate two or more adjectives before a noun. 3. Commas are used before the conjunctions <i>for</i>, <i>and</i>, <i>nor</i>, <i>but</i>, <i>or</i>, <i>yet</i>, or <i>so</i> when they join independent clauses. (A mnemonic device to remember the words is <i>fan boys</i>,* standing for the first letter of each of the conjunctions listed above.) 4. Commas are used to set off the name of a person spoken to directly or an introductory word. 5. Commas are used to set aside a descriptive phrase which is not essential to the sentence. 	I’ve worked in Orlando, Tallahassee, and Miami. She is smart, kind, and cheerful. School was awesome, for I had biology. James, can you lend me a quarter? Yes, I can help. Spike, my naughty puppy, ate my sandals.
Semicolon ;	<ol style="list-style-type: none"> 1. Semicolons are used between independent clauses not joined by <i>for</i>, <i>and</i>, <i>nor</i>, <i>but</i>, <i>or</i>, <i>yet</i>, or <i>so</i>. (<i>fan boys</i>*) 	Stretch your mind every day; you’ll never regret it.
Colon :	<ol style="list-style-type: none"> 1. Colons are used before a list of items (unless there is a verb right before the list). 	I enjoy many arts: music, painting, photography, and sculpture.
Underlining or Italics _____ <i>Italics</i>	<ol style="list-style-type: none"> 1. Underlining is used for the titles of books, magazines, works of art, ships, plays, movies, and TV shows only when handwritten. 2. <i>Italics</i> are most often used in printed material or when using a computer for composition. 	<u>To Kill a Mocking Bird</u> <u>Newsweek</u> <u>Mona Lisa</u> <u>Titanic</u> <i>Romeo and Juliet</i> <i>Star Wars</i> <i>The Oprah Winfrey Show</i>

* See *English I Teacher’s Guide* page 29.

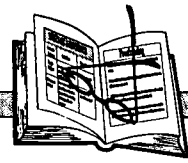

Practice

*Punctuate the sentences below by placing **quotation marks** and **underlining** where they belong.*

1. The novel *Flowers for Algernon* fascinated me.
2. Newsweek had a terrific article on steroids this week. It was called *Steroids and Teenagers*.
3. Read Chapter 32, *Modern Poetry*.
4. I shall call this sculpture *The Thinker*.
5. Which did you prefer, the book *The Autobiography of Malcolm X* or the movie *Malcolm X*?
6. My girlfriend asked me, *Where are you going tonight?*
7. *Help!* screamed the vampire's victim.
8. The television show *Ghost Writer* tries to teach us that reading is fun and important.
9. His son shouted, *Happy Father's Day!* from the car window.
10. I name this ship *Elizabeth*, said Queen Elizabeth, as she broke the bottle of champagne against the bow.

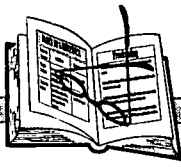

Practice

Place **commas** in the correct places in each sentence below.

1. I love the taste of chocolate kiwi and smoked mullet.
2. The man of her dreams is gentle compassionate funny and talented.
3. The secretary's day was shorter than usual yet he was still tired.
4. Count Dracula you should give up this bad habit of sleeping during the day.
5. No I can't give up flying at night.
6. Michael Jordan one of our nation's finest athletes is also a loving father.
7. Bring me the gum the bugs the false teeth and the water pistol you were playing with.
8. That brilliant creative sincere girl will be president one day.
9. You could sing jazz or you could rap at the talent show.
10. Mr. Vice President will you listen to the opinions of young people?

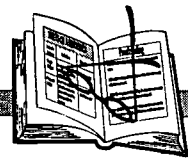

Practice

Put a **C** beside each sentence that has correctly placed **apostrophes** and an **I** beside each sentence that has incorrectly placed apostrophes.

- _____ 1. I can't sing in tune.
- _____ 2. She wouldv'e danced tomorrow.
- _____ 3. You should'not swallow your food without chewing.
- _____ 4. The men's department was very elegant.
- _____ 5. Children's toys can be dangerous.
- _____ 6. I need more friends'.
- _____ 7. Everyone's playing outside.
- _____ 8. The girl's are organizing a rally.
- _____ 9. Mind your p's and q's.
- _____ 10. Your is' look like es,' and your e's look like ls.'

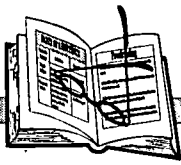

Practice

Place a **semicolon (;)** or a **colon (:)** wherever needed in each sentence below.

1. Take with you only important equipment leave behind luxury items.
2. Students from thirty schools went to the meeting they demanded smaller classes.
3. The play dealt with many issues sexism, love, stereotyping, and loneliness.
4. I want many things from life peace, harmony, and some excitement, too!
5. Falling in love is easy staying in love is more challenging.
6. The truth is often hard to find it often hides behind the obvious.
7. Please call all of the team's members Angie, Cora, Cindy, and Veronica.
8. We were shocked by what we discovered a deer living in the dog house.
9. Call me from the beach house and leave a message I will call you back shortly.
10. Remember those famous last words Watch out!

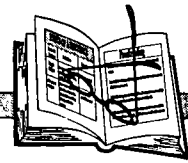

Practice

Rewrite the following poem using punctuation to make it more exciting and dramatic. You may add any of the following marks: colons, semicolons, exclamation points, question marks, underlines, quotation marks, apostrophes, commas, and periods.

A Friend

The sleek black panther that stalked me
Kept to the smoky shadows
His hot breath curled around my dreams
At night I felt his fur brush against my bare legs
Confront him
I could not
After I met you he crept away
Just like my loneliness

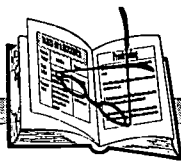

Spelling: Write It Right!

You may find that you make the same spelling mistakes over and over again. If this is the case, you might find it helpful to keep a notebook of your personal writing mistakes. Record commonly made mistakes in your notebook and refer to them while you are **proofreading**. An example is given below. The mistakes used in the example are common ones.

<input type="radio"/>	Mistakes	Corrections
	alot	a lot
	quite vs. quiet	<i>quite</i> means "to a degree" <i>quiet</i> means "silent"
	to vs. too	<i>too</i> means "also" or "more than enough"
	Febuary	February
	Wensday	Wednesday
<input type="radio"/>	there vs. they're	<i>they're</i> is short for "they are"
	whose vs. who's	<i>who's</i> is short for "who is"
	your vs. you're	<i>you're</i> is short for "you are"
	knowlege	knowledge
	necessary	necessary
	truely	truly
<input type="radio"/>	enviroment	environment

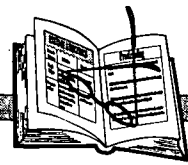

Practice

*Proofread the **spelling** in the following note. Circle the mistakes, and then rewrite the letter below.*

Dear Fred,

You know their have been quiet alot of problems with our enviroment recently. Your invited to a party on Wensday the 5th of Febuary to raise money to help the biologists clean up Lake Bradford. Nobody knows whose causing the pollution there, but you're knowlege is necessary to help us stop it. To many people are avoiding this issue. There getting away with to much.

Yours truely,
Holly

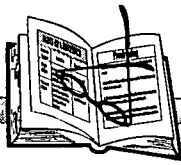

Proofreading: The Final Check

After you have gotten your writing into the paragraphs, sentences, and word choices that will best convey your message and points, you are ready to do a final and very important check. This last check is called *proofreading*. When you proofread, you check your work for misspellings, typing or word processing mistakes, omitted words, and any other problems you have not yet caught.

Writers over time have developed some good techniques for proofreading. Use them to polish your writing to a nice clean shine.

1. Say each word slowly and aloud. Don't rush through your proofreading or you will read what you think you wrote rather than what is actually on the paper.
2. Keep a list of your common spelling mistakes. Glance at these before you proofread and then double check these words when they appear.
3. Read backwards to check your spelling. Start at the end of your essay or paragraph and read to the beginning. This will force you to look at each word.

¶ Television has become the center of many americans' lives. Some people watch four to six hours a day.

[C] People worry more about the ups and downs of soap opera charakters than about there own family members.

[Family conversations center around which program (two) watch. No ^{one} knows the long-term effects of ~~X~~television on the American family.

cap

[SP]

[SP]

[SP] ^

[lc]

Before Editing and Proofing

A+ Television has become the center of many Americans' lives. Some people watch four to six hours a day. People worry more about the ups and downs of soap opera characters than about their own family members. Family conversations center around which program to watch. No one knows the long-term effects of television on the American family.

After Editing and Proofing

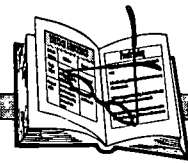

Use these professional copyediting symbols as you proofread your writing. Use them for every piece of writing you do, or when you are editing someone else's work.

Copyediting Symbols		
Type of Correction Needed	Margin Mark	Editor's Mark
Insert missing item	^	Proofre ^a ding is fun.
Insert space	#	Proofreading [#] is fun.
Insert period	⊙	Proofreading is fun⊙
Delete	/	Proofreading s is fun.
Close up extra space	∪	P roofreading is fun.
Make lowercase	lc	Proofreading is Fun.
Capitalize	cap	proofreading is fun.
Use italics	ital	Proofreading is fun.
Underline	underline	<u>Proofreading</u> is fun.
Transpose	tr	Proofreading fun is
Don't abbreviate	wo	The class is 3 credit(hrs)
Abbreviate	abbr	The stool is 3.5(feet)high.
Check spelling	sp	Proofreeding
Leave it as it was; ignore editing marks which appear above the dots	stet	The stool is 3.5 ⁴ feet high. ...
Enclose in quotation marks	↙ ↘	↙Proofreading is fun,↘she said.
Enclose in parentheses	parens	This (proofreading) is fun.
Center] []Proofreading is fun.[
Move left	[[Proofreading is fun.
Move right]] Proofreading is fun.
Fix this sentence fragment	frag	Because the stool is 3.5' high.
Equalize spacing	spacing	Proofreading ∪ is ∪ fun.
New Paragraph	¶	¶Proofreading is fun.

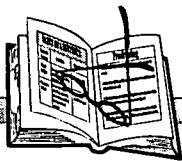

Practice

*Edit the paragraph below by using the **copyediting symbols** from the chart on page 201. Use another sheet of paper to rewrite the paragraph correctly.*

A Night I Will Never Forget

last week my sister and I were watching my baby brother while my parents were out. we were watching television when suddenly we hear a knock on the door at first we thought Mom and Dad must have forgotten their keys however when we looked out the window we saw a strange car my sister told me to open the door I did so thinking she was right behind me the person turned out to be uncle Charlie who wanted to show us his new car When I turned around to take my sister's hand I found she was gone we looked around and found her hiding behind the couch.

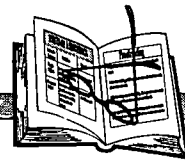

Practice

Edit the paragraph below. Then rewrite the paragraph using your editing and other necessary revisions on the lines that follow.

Students Fail For Many Reasons *by Student A*

Many people fale for many different reasons here are some. Like always doing things at the last minute. then there is failing to make up an assignment missed during an absense. I caught a huge fish yeaterday. But some are so hard headed they fail to see any potential benefit in learning today for tomorrow. But some people, just dont want to do anything just hand to him on a sliver platter.

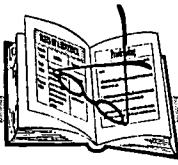

Trusty Tips for Editing

1. **Wait a while before you edit** to get some distance from the content.
2. **Reread the writing as if it were someone else's.** We tend to be overly critical of our own work.
3. **Identify strong aspects of the writing.** It is important to acknowledge what you're good at, as well as what you need help with.
4. **Ask questions** if you're not sure whether you've made a mistake. Even if you were right, you'll feel more confident the next time.
5. **Read your writing out loud.** Hearing your words helps you identify mistakes you might overlook reading silently.
6. **Point to your words as you read them.** This will help you read what is actually there, instead of what you think is there.
7. **Write clear copies for yourself** and your other proofreaders. A paper covered with corrections is hard to proofread.
8. **Read for one type of error at a time**—spelling, sentence structure, or grammar.
9. **Keep a record in a notebook of your common mistakes** and how to correct them.
10. **Use all of the tools available to help you edit**—computer spelling and grammar checkers, dictionaries, knowledgeable people, etc.

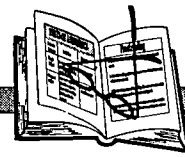

Practice

Proofread the **content** of the paragraph below by completing the directions that follow.

A. When you copy other people's style of dress, you miss out on a good way to be creative. I had a really cool time at the picnic. Are you going to town? Even trying out different ways to tie your shoes or buckle a belt can be fun.

1. Circle the topic sentence. If there is not a clear topic sentence, write one above the paragraph.
2. Draw a line through all the sentences that do not relate to the main idea.
3. Underline all sentences that relate to and support the main idea.
4. Add any additional details you think would strengthen the paragraph.

5. Number the topic sentence, all underlined sentences, and the details you would add to show how you would organize the paragraph.

Proofread the **mechanics** of the paragraph below by completing the directions that follow.

B. There are several reasons that I don't act like my friends. Sometimes my friends act so bad but they aren't and sometimes they act so childish but I just stand there and act myself.

1. Underline any spelling errors. Then write the correct spelling in the margins.

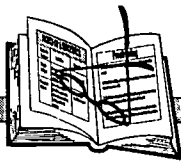

2. Circle any grammar or usage errors. Then explain the error in the margins.
3. Draw a line through any letters that should be capitalized or any letters that should be lower cased.
4. Circle any punctuation errors and put the correct punctuation in the margins.

Proofread the appearance of the paragraph below by completing the directions that follow.

C. People copy each other in several ways. *People* copy other people and don't realize it, like when someone see a friend with some shoes on that they like they go out and buy the same kind. They also see their friends smoke or something and they want to be like them and start.

1. Draw a horizontal line between words where improper spacing appears.
2. Draw a bracket—[—to show how far the first word of the paragraph should be indented.
3. Underline any words or sections that are not neat and that need to be redone.
4. Circle any unnecessary and distracting marks on each page.
5. If the margins are incorrect, draw a vertical line to show where left-hand and right-hand margins should be.

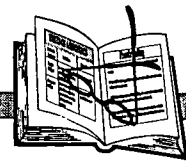

Application

Complete the following checklist as you **edit and proofread** your two documents. Then, **rewrite** your two paragraphs.

Revision Checklist		
Category	Yes	No
<u>Content</u>		
1. Is there a main idea in each paragraph?		
2. Do all the sentences relate to the main idea?		
3. Is there information in the paragraph that is unnecessary?		
4. Are specific details used to support the main idea?		
5. Is the writing organized?		
<u>Mechanics</u>		
1. Are there spelling errors?		
2. Are there grammar or usage errors?		
3. Are there capitalization errors?		
4. Are there punctuation errors?		
<u>Appearance</u>		
1. Is there proper spacing between sentences, paragraphs, and sections?		
2. Is the paragraph indented correctly?		
3. Is the handwriting or word processing neat and easy to read?		
4. Are there any unnecessary marks on the page?		
5. Are the margins correct?		

Unit 4: Listening, Viewing, Speaking— Communicating Face-to-Face

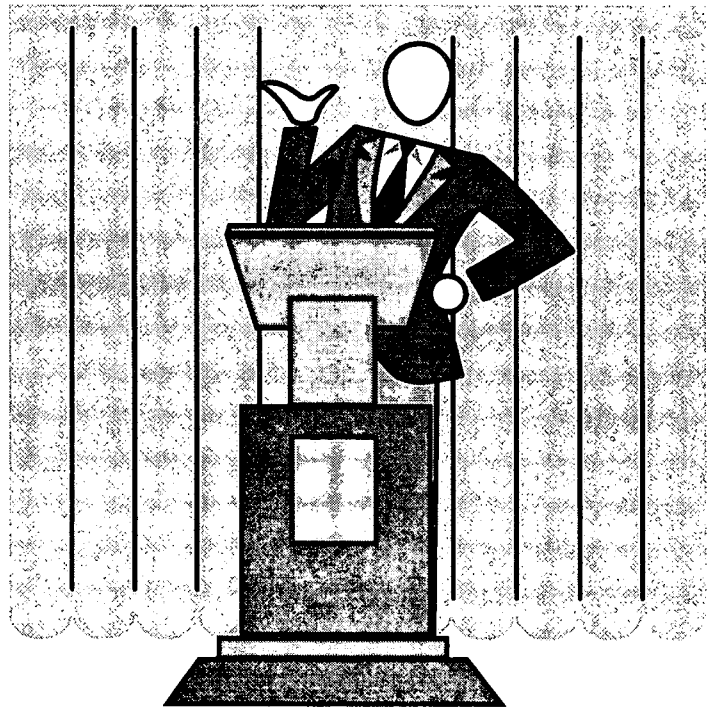

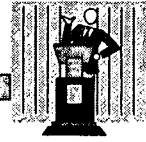

Unit 4: Listening, Viewing, Speaking— Communicating Face-to-Face

Overview

We connect with others through *communication*—the act of sending or receiving messages. You can probably think of hundreds of messages that you send and receive every day. Sometimes we send messages by using our bodies. We smile to welcome someone, or we stand at a bus stop to “tell” the driver of the next bus we would like a ride. Look me in the eye and nod your head when I speak, and I will see your interest in what I am saying. When we send or receive messages through gestures, facial expressions, or otherwise using our bodies, we are using *body language*. Body language is also called *nonverbal communication*, a way of sending or receiving messages without the use of words.

When we use words to send messages, we are using *verbal communication*. When you read a story, listen to music or a radio commercial, or write a note, you are using verbal communication. Whether your audience is one person or 40 people, you communicate well when your audience understands your message in the way you want them to. Similarly, you want to understand the messages people send to you. You also want to understand how communication can be used as a tool of persuasion. This includes knowing the ways that a sender can attempt to influence your thinking on subjects from buying a product to choosing your next president.

One of the most important acts of communication in any culture is storytelling. Storytelling is the art of telling a story to a particular audience in an interesting way. If you think back to some of the stories you have heard, you will probably agree that some stories were better than others. You may have found some stories more interesting because the subjects of the story appealed to you. Similarly, some stories kept your attention because they illustrated an interesting story or lesson. However, even an interesting story or lesson will not capture the audience’s attention if it is not told in an interesting way. A good storyteller uses storytelling techniques to gain and maintain the audience’s attention.



Our culture also uses the art of storytelling in another way: to sell products. Most of the commercials you hear on radio, see on television, or even see on billboards are brief stories intended to persuade you to buy a product or to think in a particular way. Being able to analyze the *persuasion techniques* in these advertisements will help you to make wise choices. You want to use communication rather than be used by communication!

This unit leads you through the process of becoming a good storyteller. This process begins with selecting a good storytelling story, continues with practice on using visual aids effectively, and ends with using effective techniques to tell a good story. This unit also leads you through the process of becoming a good listener or watcher. A good listener and watcher knows how to analyze what he or she is hearing and seeing. A good listener also knows how to listen with interest during a class discussion, or even during a casual discussion with just a few friends.

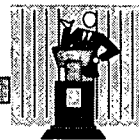

Vocabulary

Study the vocabulary words and definitions below.

- active listening** the type of listening characterized by the listener showing interest through actions and questions
Examples of active listening: taking notes, asking follow-up questions, looking at the speaker, nodding head to show agreement
- body language** the act of sending or receiving messages through gestures, facial expressions, or any other body movement or posture
- communication** the act of sending or receiving messages
- copyright** the right given by law to an author, playwright, or publisher to be the only person or company to publish or sell a literary or artistic work
- enunciation** the clear and distinct voicing of words
- nonverbal communication** the act of sending or receiving messages without the use of words (*body language* is one form of nonverbal communication)
- oral communication** the act of sending or receiving messages through speech



persuasion techniques different ways that are used to convince someone to do something, believe something, or buy something

pitch the highness or lowness of a spoken word (or any sound)

pronunciation the act of saying words correctly, as they are listed in a dictionary's guide for how a word should be spoken

tempo the speed at which words (or any sounds) are spoken

visual aids any material that can be seen (such as a prop, picture, diagram, or puppet) to help listeners and viewers understand and enjoy a presentation

volume the loudness or softness of a spoken word (or any sound)

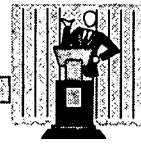

Selecting a Good Story: Matching a Story to Your Audience

When members of an audience listen to a story, they expect certain things. A good storyteller is aware of this and uses care when selecting a story and practices telling the story using good **communication** and presentation skills. It is important that the storyteller truly understands the story he or she is going to tell. She needs to understand the story's plot, characters, conflicts, and lessons. An audience will not enjoy the telling of a story by a storyteller who hasn't taken the time to learn the story and practice the presentation.

Proverbs, fables and other *folk tales* are types of stories that often make good storytelling stories. These types of stories are entertaining because the plot and characters capture audiences' imaginations and usually teach a lesson or moral to members of a particular culture. For example, in some cultures adult women might tell tales to young girls to help them prepare for marriage and childbirth. Adult men might tell stories to young boys to help them prepare for their passage into manhood.

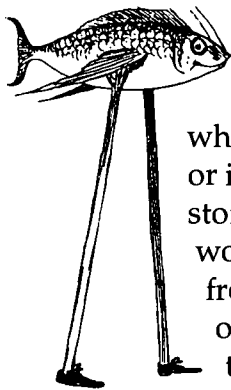

Many folk tales were told around village fires so that people could hear the tradition, history, and lessons of their culture. Some folk tales were told as plays or skits while others were shared person-to-person to teach a lesson or illustrate an idea. Some cultures use their religions to share stories or scriptures that have been handed down during worship services or passed on by missionaries who travel from land to land telling stories and teaching gospels. The one thing that most of these stories have in common is that they began with **oral communication**—with one person speaking to others.

Good storytelling tales include common literary elements. The events of stories can be fiction or nonfiction, based on truths or unexplained events. Good stories have an organized plot, identifiable characters, and interesting settings. Good stories often explain life through the setting, characters, and events of the story. It is not uncommon for characters in tales to display feelings of love, fear, jealousy, rejection, sickness, or friendship. Good stories often teach audiences about themselves.

Good tales frequently use techniques to produce an emotional response in the audience. Storytellers can use comedy to capture their audience's



emotions and help listeners relate to the events in the story. Some stories personify animals by giving them human emotions and attributes. Animals often add humor to a story and are not necessarily gender specific, so both males and females can identify with the animals' situations.

Storytellers from all ages have used **visual aids** and gestures to add to the impact of the story they are telling. Props, puppets, costumes, and pictures are all types of visual aids that can be used to enhance a presentation.

Storytelling can often be enhanced through the use of music or other sound effects. The sound of a creaky door can add to the suspense of a ghost story. A short tape of a marching band can make a story about a war come alive for the audience. Other sounds can be used to create a mood or capture and maintain the attention of an audience. Sometimes the audience can participate in the telling by creating sound effects for the storyteller. The storyteller must then direct the actions of the audience so listeners know when and what to do.

It is important to select a story that is appropriate for the listening audience. Just as a writer must choose topics and words that fit her intended audience, a storyteller must know who is going to listen to the story and select a story accordingly. Young children will enjoy stories that are easy to understand and have a simple plot. Older children enjoy adventure stories about other children their own age. Teenagers may enjoy stories about problems and solutions that they can identify with. Adults may enjoy stories that use more sophisticated techniques like complex plots and conflicts. Some stories can be enjoyed by any age simply by changing visual aids or other techniques.

Copyright: Protecting the Rights of the Owner

An author or publisher who publishes a book is protected by laws of **copyright**. Tales and stories that are original works are protected so that they may not be copied or duplicated by others without the permission of the writer or publisher.

As a storyteller, you must make sure to give credit to the original author and the publisher of the work from which you have selected your story. To do so, you must identify the following information: title of book, author(s), publisher, and the date the book was published. Your teacher will also want to know where you found the book (library, Internet, etc.).

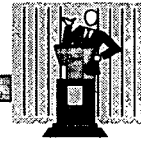

Practice

Analyze a story you have selected and read to determine if it is a good story to tell by answering the following questions.

1. Where does the story take place? _____

2. What is the cultural or historical background of the story?

3. Who are the characters? _____

4. What is the plot of the story? _____



5. What audience might enjoy hearing this story? _____

6. What techniques are used to capture an emotional response in the audience? (For example, will your audience identify with characters in the story? Will your audience find the story funny or touchingly sad?)

7. What is the lesson or moral being taught in this story? _____

8. What visual aids might be used to tell the story? _____

9. What music or sound effects can be used to tell the story? _____

330

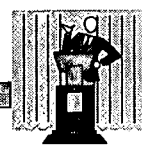

Application

Select two stories that you want to tell to a specific audience. Complete a **critical analysis** of each story by rating each one on a scale from 1 to 4, with 1 meaning poor and 4 meaning excellent. The criteria for judging each story is listed in each matrix. Add up the total score for each story. The story with the highest score is the story you should choose to tell.

Title: _____ **Author:** _____

Publisher: _____ **Date Published:** _____

Source (library, Internet, etc.): _____



1 2 3 4

The story is entertaining.				
The story teaches a lesson or moral.				
The story has an organized plot.				
The story has identifiable characters.				
The story takes place in an interesting setting(s).				
The story uses techniques to create an emotional response in the audience.				
The story is easily enhanced by using visual aids.				
The story is easily enhanced by using music or other sound effects.				
The story is appropriate for the audience.				

Total Score: _____



Title: _____ Author: _____

Publisher: _____ Date Published: _____

Source (library, Internet, etc.): _____



1 2 3 4

The story is entertaining.				
The story teaches a lesson or moral.				
The story has an organized plot.				
The story has identifiable characters.				
The story takes place in an interesting setting(s).				
The story uses techniques to create an emotional response in the audience.				
The story is easily enhanced by using visual aids.				
The story is easily enhanced by using music or other sound effects.				
The story is appropriate for the audience.				

Total Score: _____

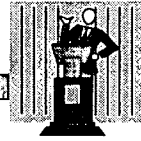

Using Effective Visual Aids: Adding Highlights to a Story

A *visual aid* is any material that depends on the sense of sight and is used to enhance a presentation. Visual aids often help to highlight or explain particular pieces of information in a presentation. They also keep the audience interested and listening.

Rehearsing with visual aids is as important as rehearsing with notecards or practicing to tell the story. It is important not to appear clumsy by dropping a picture or putting a slide in the projector upside-down. As well, you don't want to point to one picture while talking about another. Your audience will find it much more enjoyable and easier to concentrate if you appear poised and act natural while using visual aids in your storytelling presentation.

Visual aids should do the following:

- enhance, not distract
- hold the audience's attention
- relate to the story
- be easy to read and understand
- be interesting

Types of visual aids are charts, transparencies, slides, pictures or other illustrations, puppets, computer-generated images, and any other props you can use to enhance the story's plot or character development.

As a storyteller, you can also enhance your presentation by doing the following:

- Wear a costume or hat during your storytelling.
- Change your voice to reflect different characters or events in the story.
- Use gestures or other dramatic movements.
- Encourage audience participation.

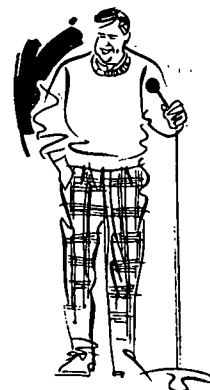



Practice

Enhance *your story* by completing the following plan.

1. How will you use *audience participation* to enhance your story?

2. How are you going to use music and other *sound effects* to enhance your story?

3. What two *visual aids* will you use to enhance your story?

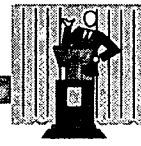

Application

*Practice and present your story using the **visual aids** and other enhancements from the previous page.*



Effective Presentation Skills: Using Your Voice and Body

Good speakers know that no matter how many good ideas they might have, if their ideas are not communicated properly, the ideas cannot be effective. Good speakers use their voices to animate their stories or presentations, or bring them to life. This begins with good voice production, which includes the qualities of *enunciation*, *pronunciation*, *volume*, *tempo*, and *pitch*. Use these guidelines to analyze your own voice production.

- **Enunciate and pronounce words clearly and distinctly.** Avoid mumbling or running words together. Separate words just enough for them to be heard. Pronounce every sound in each word that you say.
- **Speak at a suitable volume—neither too loudly nor too softly.** Control the volume to express the content of your speech or your feelings. (*Speak softly when reading a poem about a child and loudly when reading a poem about a baseball game.*)
- **Speak at a suitable tempo—neither too slowly nor too quickly.** Pay attention to the natural rise and fall rhythm of the language.
- **Make the pitch of your voice appropriate to what you are expressing—neither too high nor too low.** If you want to calm down the audience, keep the pitch or tone of your voice low and calm. If you want to excite an audience, use an enthusiastic tone or high pitch.

Good speakers also make their speech flow evenly. In casual conversation people commonly say words and sounds that should be avoided in formal

oral presentations. Study the following list and ask a friend to help you identify which expressions you use frequently. Add your own expressions to the list if it does not cover them.





Presentation's
TOP 10 EXPRESSIONS
TO AVOID!!

1. *Um . . .*
2. *Well, . . .*
3. *Ya' know . . .*
4. *Like, um, . . .*
5. *I mean . . .*
6. *So . . .*
7. *I guess . . .*
8. *Er . . .*
9. *Gosh, Geez*
10. *Huh! Huh? Hmph.*
- 11.
- 12.

Brought to you by
Dana Letterwoman

Many people feel nervous when they speak to a group. Understanding what is meant by a "good speech" and knowing the characteristics of a "good speech" are your best tools for delivering a speech that your particular audience will enjoy.

When we are making presentations, we also need to be aware that we communicate through our postures, our gestures, and our facial expressions. What we communicate with our bodies can either add to or detract from what we are saying. Very large or exaggerated body language can cause our audience to watch our movements rather than listen to what we are saying. By being aware of this and learning some body language guidelines, we can improve our **nonverbal communication** as well as our ability to make good oral presentations.

Tips for Using Presentation Body Language

Stand straight, with one foot slightly in front of the other. Keep your posture relaxed and natural. Standing straight will increase your ability to breathe deeply and easily, making your voice quality sound its best.

Maintain eye contact by looking at members of the audience during the entire speech. Be sure to move your eye gaze around the room, looking at as many people as possible. Looking at one area or one person will make the listeners uneasy. Moving your gaze will make everyone feel included in your presentation and that you are talking *to* them and not *at* them.

Keep your face expressive. Use your face and body to get the message across to the audience. Make sure that any emotions shown are appropriate to your speech. A cold, stony expression will make you look disinterested, while the audience will be lost to boredom.

Use gestures and shifts of posture to emphasize key and important ideas or statements. Let your arms and hands rest naturally at your sides (or rest on a lectern) until they are used to make expressive gestures.



The characteristics listed on the following chart will help you to deliver a good speech. This, in turn, will help you to gain confidence when you speak to an audience. Use this checklist to practice telling your story.

Characteristics of Good Oral Presentations		
Elements	Characteristics	Definitions
Preparation	1. Subject Knowledge	- the presentation subject is thoroughly researched and the speaker is prepared for any questions that may be asked
	2. Organization	- the presentation material is arranged or put together in an orderly way—using index cards, outlines, or visual materials to keep presentation well paced and on track
	3. Audience Awareness	- the presentation is prepared for the type of audience receiving the information—speaking or writing is appropriate for and understood by the target audience
Speaking	4. Enunciation	- words are spoken clearly, without mumbling, making each sound distinct
	5. Pronunciation	- words are spoken according to a dictionary's pronunciation guide
	6. Volume	- the sound produced by the voice is not too loud or too soft; the sound changes during the presentation to match what is being described
	7. Tempo	- the speed at which words are spoken is not too fast or too slow; the speed may change to match what is being described
	8. Pitch	- the highness or lowness of the sound of the voice matches what is being described
	9. Expressiveness	- the presentation (or words) are communicated in a vivid and persuasive manner
	10. Complete Sentences	- the presentation uses a group or groups of words that present a complete thought
Body Language	11. Eye Contact	- the speaker looks directly into the eyes of one or more persons—communicates speaker's confidence, alertness, and empathy with the audience
	12. Natural Gestures	- the speaker uses normal movement of the hands, head, or other body parts to express the speaker's thoughts or feelings—gestures should emphasize presentation points, not distract from them
	13. Good Posture	- the speaker carries or holds his body in a straight alignment while sitting, standing, or walking—conveys confidence and readiness; slouching conveys the opposite—uncaring, unreadiness, indifference

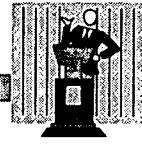

Practice

*With a partner, practice **enunciating** when you say these tongue twisters out loud. Remember, the object is not to say them fast, but to say them clearly. If there are words you cannot pronounce, use a dictionary's phonetic spelling, or ask your teacher to help you.*

Remember! Don't drop the last sound of a word when you speak.

1. The big black bug bit the big black bear.
2. The very merry Mary crossed the ferry in a furry coat.
3. Bring me some ice, not some mice.
4. Twenty talented teachers teaching tiny tots their twice times table.
5. Please sell me some short silk socks and some shimmering satin sashes.



Practice

Choose a poem, song lyrics, or a paragraph to read and record on tape. Have a friend evaluate your speaking performance using the chart below. (You may have to listen to the tape several times in order to evaluate each category.) Then read the passage again on the tape. Try to improve on the skills in which you were weak.

VOLUME	Too Loud	Loud & Clear	Too Quiet	Comments
TEMPO	Too Fast	Even Pace	Too Slow	Comments
PITCH	Too Low	Moderate Pitch	Too High	Comments

310

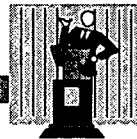

Practice

*Rewrite the following words so that if they were spoken correctly, all of their sounds would be heard. Practice **enunciating** the correct form of each word aloud.*

1. gonna: _____
2. haft: _____
3. could of: _____
4. wanna: _____
5. gettin ready ta go: _____
6. swimmin: _____
7. will ya: _____
8. whad ya half: _____
9. wooda: _____
10. gotcha: _____



Application

Use the form below to apply your **presentation skills**. Have a classmate rate you on the following criteria as you practice telling your story. It is important to remember that you are still practicing and that you can change your technique during this application. Make changes to your storytelling based on the feedback below.

VOLUME	Too Loud	Loud & Clear	Too Quiet	Comments
TEMPO	Too Fast	Even Pace	Too Slow	Comments
PITCH	Too Low	Moderate Pitch	Too High	Comments

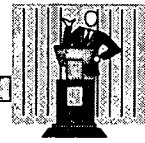

Persuasion Techniques: Pressing Our Buttons

Stories of one kind or another fill our day. Sometimes *we* tell the story. We may tell a story in a formal setting, as you did when you told a story to your class. You many tell a story in a casual setting, as you have when telling a funny happening at a party or at lunch.

Sometimes stories are told to us. A friend tells us about an exciting adventure or about the way her grandmother learned to walk steel girders twenty floors above the ground. Another kind of story we hear or see many times a day comes from the media—television, radio, newspapers, and magazines. Some of these stories come in the form of commercials or advertisements. These are stories meant to persuade us to buy something or to believe something.

Historians claim that people began advertising their services as early as 1000 B.C. If so, advertising has been around for along time, but it has changed through the years. In its earliest form, advertising informed consumers of the product and the price. Over time, however, advertisers have added a twist. They began attempting to make us believe that unless we buy their goods, we are incomplete, less lovable, even less human!

Advertising will probably always surround us. We can't change that, even if we wanted to. We can, however, be aware of how advertisers try to hook us into buying their goods. This education can help keep us from buying things simply because we were convinced we needed them for our happiness. Happiness, popularity, and romance are never as easy as buying a pair of jeans or drinking a soda.

The various ways advertisers try to push our buttons are called *persuasion techniques*. The following paragraphs identify and explain the most common techniques used by advertisers. Most of the time, advertisers use them to sell us something in exchange for our money. However, this is not always the case. A politician may try to persuade us to vote for him or her. An organization may use advertisements to get us to adopt their position on an issue. It may want us to believe that we should stop doing experiments on animals or that we should build another elementary school in our town or city.

Obviously, there are many good products we can buy and many politicians we would want to support. There are also many good positions on an issue we may want to adopt. The point is, however, that you want to



know the techniques being used to sell you something. The educated consumer can then avoid being moved by empty words and make a decision or choice based on good thinking.

Celebrity Testimonials: The Famous Face

You see it on television all the time. A celebrity sells something. Michael Jordan sells underwear. Cindy Crawford sells soda. A famous athlete sells a sports drink. A beautiful actress sells shampoo. We'll never know if these people use the products they sell. They advertise these products for one reason: money—they are paid lots of money. Buy a product because you think it has value, not because a famous person tells you to.

Glittering Language: Empty Words

Take a look at the language in some ads. Note how phrases such as *the best*, *this is it*, and *it's the real you* are used. Do they really say anything? In what way is this product *the best*? If this product *is it*, what exactly does it refer to? And how can an advertiser really know what the *real us* is? Ads often use meaningless language that is intended to catch our ear and suggest something bigger than life. Listen closely to ads to become a wiser consumer.

Appealing to Our Emotions: Playing on Fear

Many ads play on our emotions. They try to make us feel insecure about ourselves. If we don't use this toothpaste, our teeth won't shine and we'll lose out on love. Use this deodorant or you'll never get that job you want. Drive this car or you're a failure—and everyone will know it! Don't let advertising convince you that your life is incomplete and has no value unless you buy a certain product. Don't let ads tell you who you are or whether you're a success. Be an independent thinker and a wise decision maker.

The Either/Or Appeal: Making You Choose One or the Other

Another form of appealing to our emotions is the *either/or appeal*. Some ads try to persuade us that we have only two choices. "Look," they say, "you either buy this product and have the best, or you don't buy it and have the worst." This line of thinking suggests that if you don't buy the best and most expensive car, then you will end up with an unreliable and

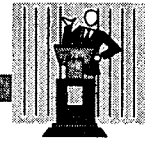

unsatisfying car. Of course, there are many possible cars between these two extremes that you can buy. And many of these cars are quite reliable and will make you happy. Whenever an ad suggests only two possibilities, sound the alarm and drown out all that false logic.

Get on the Bandwagon: The Majority Always Knows Best

Advertisers are particularly fond of this technique. They claim that something is good or the best because many or most people are using it or doing it. But there are many reasons why a product may be the most popular. A company may spend millions of dollars on ads to make people aware of their product. When people go into a store they are most likely to buy products they have seen or heard about in the media. The popularity of a product may mean nothing more than that a company spent money to make the product's name a "household name."

Abusing Statistics and Facts: Claims Built on Half-Truths

Consider the following ad: "Studies have shown that on those days when people buy the most ice cream, more crimes are committed; so let's stop selling ice cream and reduce crime." This ad is quite slippery, for a part of it is true. Crime in cities does tend to go up when people buy a lot of ice cream. However, this fact does not mean that buying ice cream makes people more apt to commit crimes. People buy more ice cream when the weather is hot than when it is cold. Similarly, more crimes are committed when the weather is hot than when it is cold. To claim that ice cream has any relation to crime is an abuse of statistics. Banning the sale of ice cream would not reduce crime, it would only deny us a popular pleasure.

The Hasty Generalization: Big Claims Made on Little Evidence

Some claims are based on very little evidence. Advertisers may take a small sample and use it to make a statement about a much larger group. For example, an ad may claim that most of Glittertown loved their new Sidewinding Exograpian Bicycle, and so everyone will love this new-fangled bicycle. Now we may be glad that Glittertown loved riding bikes on which the rider is upside down and pedals with his or her hands. However, the people in Glittertown may be quite different than the people in your town. To claim that because Glittertown loved the Sidewinding Exograpian Bicycle so will your town is a hasty generalization. It is a claim made without sufficient evidence.



Practice

Next to each claim below, write the persuasion technique that has been used.

Celebrity Testimonials	Glittering Language
Appealing to Our Emotions	The Either/Or Appeal
Get on the Bandwagon	Abusing Statistics and Facts
Hasty Generalizations	

- _____ 1. We have not cured cancer. Either we should put billions more into cancer research or we should stop funding cancer research completely.
- _____ 2. Four million Circle the Moon Hula Hoops have been sold—nearly everyone is doing the Hula Hoop Twirl! Join the rest and buy a Circle the Moon Hula Hoop today!
- _____ 3. The world famous singer Ida Wirble wears Ziggy Basketball Shoes. She wears them, shouldn't you?
- _____ 4. If you really want to be you, you'll buy the Supercolossal All-World Wristwatch! How can you know who you are if you don't know the time on every planet in the Milky Way?
- _____ 5. If we're serious about ending hunger, we will all buy more Twinkle Bread. In each year that Twinkle Bread has increased its sales, hunger in the world has dropped.



- _____ 6. We raised taxes last year to build new roads. Well, those new roads have not eased traffic jams. We should never raise taxes again!
- _____ 7. We know you'd like to have everyone love you and think you're beautiful. Well, now you can achieve your dream. Simply brush your teeth with LUVS Toothpaste and romance will be yours, forever!



Application

*On the lines below describe three different ads that you see or hear quite often. After each ad, write the **persuasion technique** that is being used. You may find that more than one technique is being used in an ad. If so, describe all the techniques you recognize.*

Ad #1: _____

Persuasion technique(s) used: _____

Ad #2: _____

Persuasion technique(s) used: _____

Ad #3: _____

Persuasion technique(s) used: _____

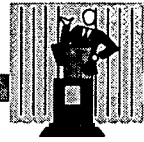

Application

*As your teacher plays a radio commercial for your class, follow the steps below to help you develop a **group analysis** of the **persuasion techniques** being used.*

Step 1: After listening to the commercial the first time, answer the following questions:

1. What is the commercial attempting to sell? _____

2. If you find the commercial interesting, explain why. (If not, move on to #3.)

3. If you did not find the commercial interesting, explain why.

4. Do you think you would buy this product if you could? _____

Step 2: Read the questions below and then search for answers as you listen to the commercial for a second time:

1. To which audiences do you think this commercial is aimed?

2. What in the commercial leads you to think that this is the audience at which the commercial is aimed?



3. What persuasion techniques do you find being used in this commercial?
4. Do you think these techniques are persuasive for the commercial's audience?

Why or why not? _____

Step 3: Read the questions below and then search for answers as you listen to the commercial for a third time:

1. Do you recognize any *other* persuasion techniques being used in this commercial?

2. Now that you have recognized the persuasion techniques being used in this commercial, are you more or less likely to buy the product?

Why? _____

Step 4: Now join your class in a discussion on the persuasion techniques used in this commercial. Try to come to agreement on which techniques are being used and whether those techniques are effective in selling the product to its intended audience. During your class discussion, practice the discussion skills that follow.

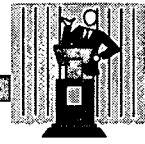

Discussion Skills: The Art of Listening and Speaking in a Group

In a group discussion, a group of people sit down together to talk about a problem, to make a decision, or to understand one another's ideas. In the classroom, the topic of the discussion is most often regulated by the subject of the class or the concept that the teacher is teaching. The group discussion is not just a conversation—everyone must be allowed to participate and voice opinions. However, the opinions cannot be voiced at the same time as in a free-for-all. There must be planning on the part of the participants and guidelines for every participant to follow. Some of the guidelines are as follows:

Listen completely to others: Think of words as building bridges between you and others. Make those bridges healthy ones by listening carefully to everything others have to say. Do not interrupt others. Wait until you are sure a speaker is through before speaking.

Empty your mind when others speak: To fully listen to someone, you must empty your mind and carefully consider his or her statements, questions, and points. Often we clutter our minds with the words and ideas we want say during a discussion. A good way to unclutter your mind is to write down the thoughts you want to add. In that way, you can open your mind to other speakers and feel confident that you won't forget your own valuable additions to the discussion.

Be strong enough to be moved by others' ideas: Let the statements and points others make affect you. In other words, don't hold on to your own ideas too tightly. If someone makes a good point that disagrees with you, reconsider your own idea. You might even make it a (good) habit to thank someone else for helping you to reconsider, or to *re-see*, your own ideas. A person who has self-confidence is not afraid to admit that someone else is right.

Make a contribution: No one likes someone who only takes but doesn't give. Don't just sit and let others do all the work in a group discussion. Come to class prepared so you will be able to add to and improve the discussion

Stay calm: Use a calm voice to express opinions. Speaking louder than others will not convince them of your ideas. Let the strength of your ideas speak loudly rather than the volume of your voice. Use solid reasoning, illustrations, and/or facts to explain and support your opinions.



Active Listening: Absorbing Information and Ideas

Although listening skills have been discussed above, they are so important that they deserve additional focus. Most of the time when we are listening to a speaker giving a formal presentation or even talking informally in a class discussion, we are usually listening for information to remember or to understand. Being an active listener means determining which information is most important and then absorbing that information. As active listeners, we have to listen to determine the speaker's main ideas and the supporting details of the presentation or class discussion. Taking notes on the main ideas helps the listener to follow the discussion and to remember it later.

Here are a few guidelines to being an active listener at all times.

- **Be sure that you understand the speaker's purpose.** Is the speaker's purpose to inform, to entertain, or to persuade? Understanding the purpose allows the listener to focus on the information that supports the purpose.
- **Listen for words that tell you where the speaker is going and how ideas are connected.** Listen for words that indicate time sequence (*first, then, last*), spatial relationships (*near, far, in the middle*), additional ideas (*besides, to, moreover*), or results (*therefore, as a result of, accordingly*).
- **Ask yourself questions to help identify the main ideas and supporting details.** ("What main idea do these examples support?") Find relationships between the speaker's ideas.
- **Pay attention to any visual aids that the speaker uses.**
- **Take notes on important information.** Taking notes helps in organizing and remembering information. Focus on the information that you determine is important. Use abbreviations, words, and phrases rather than full sentences.

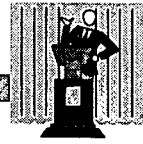

- **Active listeners also need to be aware of their body language.** So that everyone is interacting, listeners need to let the speaker know that they are listening. This gives the speaker a chance to assess his presentation, and adapt according to how the listeners seem to feel and what they do or do not understand. Here are a few guidelines of body language for the listener.

Look at the speaker. It triggers listening skills and concentration. If the speaker assumes that no one is listening, the speaker may become nervous and unable to adapt the presentation to the audience.

Nod your head when you agree or understand. Then the speaker will be sure that you are listening, that you do understand, and that the presentation is on the right track.

Sit up and don't fidget. Fidgeting may distract the speaker and other listeners. Sitting tall will help you to concentrate on what the speaker is saying.



Application

*Your teacher will divide your class into groups of four. Each person in the group will be given a paragraph to read to the other three persons in the group. As each person reads his or her paragraph, the other three classmates will practice **active listening**:*

- understanding the speaker's **purpose**
(to inform? to entertain? to persuade?)
- listening for words that indicate
time sequence (*first, then, last*),
spatial relationships (*near, far, middle*),
additional ideas (*besides, in addition, moreover*), or
results (*therefore, as a result of, accordingly*)
- using questions to identify the **main idea(s)** and
supporting details
(*What main idea do these examples support?*)
- paying attention to any **visual aids** the speaker uses
- taking notes on **important information**
(*Use abbreviations, words, and phrases rather than full sentences.*)
- using **body language** to let the speaker know you are interested
(*look at the speaker, nod your head to show you understand or agree, sit up and don't fidget*)

After each person presents his or her paragraph, the three listeners in the group will compare their notes. The three listeners should come to an agreement about the speaker's purpose, main idea(s), supporting details, and any other important information.

Unit 5: Literature— Discovering the World, Discovering Ourselves

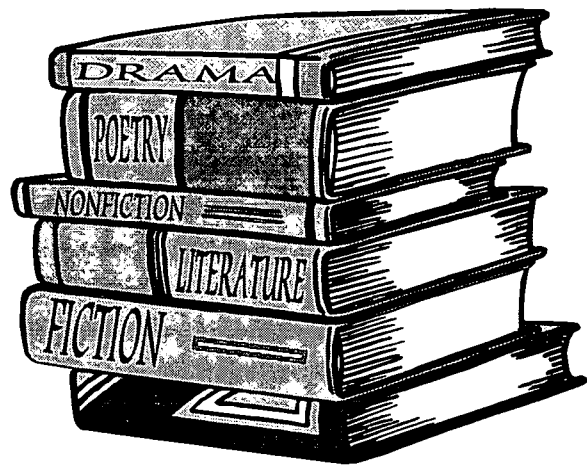



Unit 5: Literature—Discovering the World, Discovering Ourselves

Overview

Literature—writing that has lasting value—is characterized by its use of language that is elastic and powerful. Writers can stretch their words into riveting drama or squeeze them into stunning poetic images. Writers and the literature they create have the power to capture the emotions that come with being human: triumph, passion, or loneliness. When we read literature we know that we are not alone, that across history others have shared our experiences and emotions.

All literature is either *fiction* or *nonfiction* or a combination of both. In this unit you will learn about the differences between fiction and nonfiction, the different forms of literature called *genres*, and common literary elements. At the end of this unit you will select a piece of literature, analyze it, and decide whether or not you would recommend it to other students. Your work throughout this unit will provide you with the tools and knowledge to help you complete this task.

Literature can open a whole universe of possibilities to a critical reader. It can take you to exotic places, introduce you to famous people, or teach you about yourself. Once you have unlocked the key to understanding literature, the world is just an open book away!



Vocabulary

Study the vocabulary words and definitions below.

- antagonist** a character in conflict with the protagonist or main character
- autobiography** nonfiction in which the author tells his or her own life story
- biography** nonfiction in which the author tells the life story of another person
- character** a person or creature in a literary work
- climax** the most suspenseful point in a (literary) work; the point at which one of the two opposing forces must give way to the other
- comedy** a type of drama or literary work which has a happy ending and often points out human weaknesses and flaws in a humorous way
- conflict** a struggle between opposing forces, (often characters); can be internal or external
- drama** a type of literary work in the form of dialogue between characters; meant to be performed and seen rather than read



- fiction** writing based on imagination; may involve real people or events as well as invented ones
- genres** different categories into which literary works are grouped
- literature** writing in which expression and form are important features, such as poetry, fiction, biography, essays, etc.; writing that has lasting value
- metaphor** a comparison between two different or unlike things
Example: calling a life change turning over a new leaf
- narrator** the speaker in a literary work
- nonfiction** writing based on real people, events, and facts rather than on imaginary ones
- novel** a long work of fiction in which characters and conflicts can be explored in great depth
- personification** giving human qualities to an object, animal, or idea
Example: The sky is crying.



- plot** the skeleton or outline of a literary work; the sequence of the main events in a work
- poetry** a type of literature written in verse and expressing strong feelings
- protagonist** the main character
- rhyme** sounds at the end of words which are repeated in the writing; used particularly in poetry
Examples: nap and rap
- rhythm** a pattern of beats based on stressed and unstressed syllables; used particularly in poetry
- setting** the time and place in which the story takes place
- short story** a short work of fiction usually focusing on a few characters and a single conflict
- simile** a comparison between two different or unlike things using the word *like* or *as*
Example: That chair is light as a feather.
- suspense** a technique used to create uncertainty so that the reader will stay interested in the story



theme the central idea or message of the literary work; often a lesson about life

tragedy a type of drama or literary work that shows the downfall or the destruction of a noble or outstanding person



Fiction and Nonfiction: The Imagined and the Real

Fiction is writing based on imagination, whereas **nonfiction** is based on real people or events. A work of fiction can take many different forms. It can be a **short story**, a **novel**, or a tall tale. Regardless of its form, a work of *fiction* tells a story. A story describes an event or a series of events unfolding. Sometimes these events can be dramatic, such as a woman scaling a high mountain to rescue her lost husband. Sometimes the events can be quite ordinary, barely noticeable to an observer, such as a young man shopping at a supermarket. Regardless of whether it tells about a high adventure or a common experience, a story that has sprung from the writer's imagination is a work of fiction.

Like a work of fiction, a work of nonfiction may take many different forms. It can be a **biography**, **autobiography**, essay, cookbook, newspaper article, or a true-to-life adventure story. All of these examples are types of nonfiction because they are based on factual information, real people, and real events. Culture and history are both reflected in works of fiction and nonfiction. This influence can often be seen in the attitude of the author, the **setting**, the events, and the **characters**.



Sometimes it is easy to tell the difference between fiction and nonfiction. It is obvious that a story about a super hero or grotesque monster is fiction. We know that it is unrealistic to think that such a tale could be a retelling of factual, real-life events. It is also obvious that a story written by a famous person about her own life is probably nonfiction. We know that the famous person probably wrote about events that actually happened to her. Basing a story on factual, real-life events makes it nonfiction.

Other times it is more difficult to distinguish between fiction and nonfiction. Because all writing is to some degree inspired by real experiences and requires imagination, how do we know which is real and which is made up? In addition, there are many books featuring real events, such as the Civil War, the sinking of the *Titanic*, and the string of bank robberies by Bonnie and Clyde. Are these books fiction or nonfiction? To answer these questions, it is helpful to consider the author's *purpose* in writing the work. Usually, the main purpose of nonfiction is to inform, educate, or persuade using factual information.

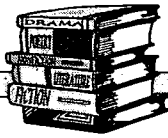

The main purpose of fiction, however, is to entertain. Good, thorough nonfiction writers also use reliable sources upon which to base their information.

	<i>Fiction</i>	<i>Nonfiction</i>
Types	short stories, novels, tall tales, some poetry, comic books, some dramas	true-life adventure stories, essays, biographies, autobiographies, cookbooks, magazine, and newspaper articles
Based On	imagination	real people or factual, real-life events
Main Purpose	to entertain	to inform, educate, or persuade using factual information



Practice

Put an **F** beside writing that is **fiction** and an **N** beside writing that is **nonfiction**. Be prepared to explain your answer.

- _____ 1. a newspaper article
- _____ 2. a short story
- _____ 3. an autobiography
- _____ 4. a resume
- _____ 5. a movie
- _____ 6. a biography
- _____ 7. a magazine article
- _____ 8. a science report
- _____ 9. an encyclopedia
- _____ 10. a recipe
- _____ 11. a set of directions
- _____ 12. a story about a purple giraffe on the moon
- _____ 13. a research paper
- _____ 14. a fairy tale
- _____ 15. a travel guide book



Practice

Answer the following questions.

1. In the library, poetry is classified as nonfiction. Based on the poetry you have read, would you classify it the same way? Why or why not?

2. Imagine you are an expert on the sinking of the *Titanic*, the ocean liner that hit an iceberg and sank. You are reading a book on the *Titanic* and enjoying the accuracy with which the author describes this ocean liner. However, you notice that many of the characters in the book were not actually on the real *Titanic*. Would you consider this book a work of fiction or nonfiction?

Why? _____

3. A young journalist writes an article about prejudice for his school paper. His article is based on interviews as well as research. Is his article fiction or nonfiction?

Why? _____



History and Culture in Literature: Events and Values Depicted in Stories and Reflected through Writers

When you read your history book, you learn information about what happened in the past. When you read a work of **literature**, you find out how historical events have shaped the people who experienced them. You also find out how a particular culture influenced the people who lived in it. Defining a particular culture is difficult, perhaps even impossible. We can, however, agree on certain characteristics of a culture.

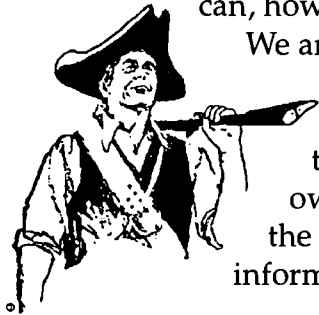

We are part of the American culture. It is a culture that admires independence, from the men who declared national independence from England to the men and women who have struck out on their own and formed successful businesses. We also live in the culture of the 1990s. This decade has valued information—this period is called the Information Age.

An example of the way history and culture work in writing can be seen in a novel about the Depression Era in the United States. The Depression occurred during the 1920s and 1930s. Although the writer herself lived long after this time of extreme poverty and unemployment, she developed an interest in the period. She wanted to show how cultural values affected people during this time. She shows many characters in her novel who are extremely bitter because in spite of their hard work they are unable to feed and shelter their children. In short, their hard work is not rewarded, and they do not enjoy the American dream.

The writer also shows how events in history contributed to the Depression: how the end of World War I left people with hopes for a comfortable future; and how the hunger for a wealthy lifestyle caused many people to fall into enormous debt. In the novel's last chapter, she shows how even though the people in the next generation regained some wealth, they lived forever in fear of another depression. This work of fiction shows us a particular history and culture and how they affected people.

The historical period and culture in which a writer lives also influences how and what she writes. Certain historical events provide experiences that many writers of a particular culture or time period react to in their work. Careful readers, therefore, can often recognize the literature of a particular time, place, or people.

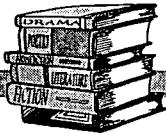

Many southern writers have been affected by slavery, the Civil War, and Reconstruction after the war. In addition, the South was, for a long time, industrially underdeveloped. This resulted in small towns and an agricultural lifestyle. This in turn resulted in the inhabitants feeling close to the land and in tune with the cycles of nature. Southern writers have also been heavily influenced by the myths and stories of the antebellum South—or the South before the Civil War. Most of us are familiar with the stereotypical characters who are identified with this time period. These characters include the southern belle and the southern gentleman. Even today, more than a hundred years after the Civil War and Reconstruction, many Southern writers are still influenced by these events and the “old” South. These writers often address some or all of the following southern themes in their works:

- a strong interest in the past
- a love of the land
- the difficulty men and women have in breaking with traditional roles
- racial injustice
- stereotypical characters
- a gap between the rich and poor
- strong family ties
- the will to survive disasters



Practice

Choose one **fiction** and one **nonfiction** work set in two different regions or cultures. Complete the following chart with information from your selected readings.

	<i>Fiction</i>	<i>Nonfiction</i>
Title of Work		
What is the setting, or geographical location, of the work?		
Which historical events are described in the work?		
What stereotypical characteristics are presented in the work?		
What cultural or ethnic influences can be identified in the work?		
What economic backgrounds are depicted in the work?		

367

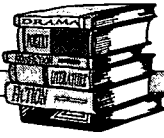

Practice

Write one or more paragraphs comparing the cultural and historical influences present in the two works. Develop your own comparison or use one of the following questions:

1. How do the cultural and historical influences affect the behavior of the characters?

Do all of the characters in each work respond in the same way?

2. How do the cultural values shown in these two works differ?

3. In spite of the different cultures and histories in each work, what values are similar in both works?

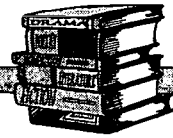

Application

Read one piece of **nonfiction** and one of **fiction** that are both on the same topic. Compare the two selections by answering the questions below. If you need more space, use your own paper.

Title of Work of Nonfiction: _____

Author: _____

1. What does the author show, explain, or argue in this work? _____

2. What three things did you like about this piece? _____

3. What, if anything, made reading and understanding this piece difficult?

4. How are history and culture reflected in this work?



Title of Work of Fiction: _____

Author: _____

1. What does the author show, explain, or argue in this work? _____

2. What three things did you like about this piece? _____

3. What, if anything, made reading and understanding this piece difficult?

4. How are history and culture reflected in this work?

5. Write a short analysis that explains whether you liked the fiction or nonfiction work best.

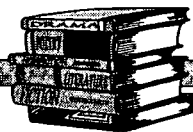

Common Literary Elements: The Parts that Make Literature Go

Literature includes certain common ingredients that work together to make a story, poem, **drama**, autobiography, or biography interesting to read. These common ingredients are called *literary elements*. Not all of these elements appear in every genre. Knowing the terms used to talk about literary elements will help you as you study the forms of **genre** in the rest of this unit.

Plot: The plot is the skeleton or outline of a literary work; it is the sequence of main events that takes place in the story. In addition, the plot also shows us why things in the story occur. The British author, E.M. Forster, said that if



someone told you the king died and then the queen died, they would be only telling you of two events that happened and be describing only half the plot. However, if they told you that the king died and then the queen died of *grief*, they would be describing the whole plot. In other words, the plot includes the cause (the king's death) and its effect (the queen's death).

The plot of many works of literature follows a structure or order.

The Beginning: Most beginnings give us information. We discover who the main characters are, where and when the story takes place, and any other information we need to make sense of what follows. The beginning also accomplishes something essential to a good story. The beginning suggests that something will happen to upset the situation presented. So, for example, the beginning of *Little Red Riding Hood* suggests that the young girl will not just stroll happily to Grandma's house. No, something will change to upset this lighthearted and innocent picture.

The Middle: The middle is often the longest and most intense part of a literary work. In the middle, conflict

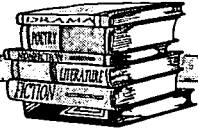

upsets the picture presented at the beginning. Take the story of Belinda. She left home on a beautiful sunny day to catch the public bus for school. She sat next to her friend Missy, who asked Belinda if she would like to cut school for a day of goofing off at the mall. Thus began the conflict: Should Belinda cut school or should she risk Missy's disapproval by going on to class? When the bus reached school, the conflict had reached its high point. Belinda had to choose whether to attend class or skip it. The high point in a story is called the *climax*.

The End: The end of a story is also called its *resolution*. The conflict is resolved, or decided. The ending often also shows the effects of the resolution. After deciding to cut class, Belinda faces all the effects of her decision. She has flunked a quiz and lost her purse at the mall. Perhaps worst of all, she felt bad because she was not strong enough to accept Missy's disapproval and go to class.

Character: A character is a person or creature in a literary work. We generally speak of *round* characters and *flat* characters. We see many sides of a round character. The round character has the ability to grow, in good ways or bad. The character who spends his life making a fortune but comes to see that he has no spiritual wealth is an example of a round character. Round characters seem more lifelike to readers because they are complex, as people are in real life. In contrast, we see only one side of a flat character. No matter what happens, he or she responds in the same way. The flat character is identified by a single attitude or behavior. Little Red Riding Hood is innocent and good. The wolf is devious and bad.

Protagonist: The protagonist is the main character. The protagonist is the most important character. In many stories, the protagonist is the character readers identify with. A common practice by writers is to use the name of the protagonist as the title of the story or play. Most fairy tales follow this practice, for example, *Little Red Riding Hood*, *Snow White*, *Jack and the Beanstalk*. Shakespeare

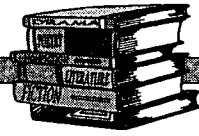

named many of his plays after the protagonist: *Hamlet*, *Romeo and Juliet*, and *Othello*.

Antagonist: The antagonist is the second most important character or characters in a story. The antagonist is in conflict with the protagonist. The antagonist tries to keep the "good guy" from achieving his or her goal. The antagonist in the fairy tale *Little Red Riding Hood*, for example, is the wolf. The wolf tries to keep Little Red Riding Hood from reaching her goal—delivering goodies to Grandma. In Shakespeare's *Hamlet*, the antagonists are King Claudius and Laertes. As antagonists, King Claudius and Laertes work against Hamlet's goal: to avenge his father's death.



The wolf from *Little Red Riding Hood*

Setting: The setting is the time and place in which the work takes place. However, the setting tells us more than just the physical location in which the work is set. If a work is set in New York City, for instance, a whole set of values and expectations will be raised. The characters in this story will move through a city heavily influenced by modern urban life. If a man were to talk to an unfamiliar woman at a bus stop in a large urban city, other people would barely notice. However, if this same incident happened in a small rural town, it could become a major source of gossip and ridicule. The setting of a play not only depends on the environment of the story but also on the stage setting, the lighting, sound effects, and language.

Conflict: The conflict is a struggle between opposing forces. The conflict can be internal, within the mind of the character. A woman, for example, does battle with her self-doubt. She either has to persuade herself that she can run a corporation and manage a whole staff of men or she has to turn down a huge promotion. The conflict can also be external, between two characters. A boy, for example, tries to persuade a girl that her boyfriend has cheated on her. She will either dump her boyfriend or



realize that the other boy is being devious. Another kind of external conflict occurs between a character and some other force, such as society or nature. A boy lost in a blizzard and freezing will either lie down and freeze to death or use his calmness and cleverness to survive nature.

Climax: The climax is the most suspenseful point in a literary work. At the climax, the two opposing forces have reached the high point of their conflict. Something must give. The protagonist will either triumph, fail, or find some condition in-between. Will self-doubt overcome the woman or will she silence it once and for all? Will the boy lost in a snowstorm lie down and freeze to death or will he keep calm and endure a blizzard? Will John persuade Lindsay that her boyfriend, Max, has cheated on her or will she realize that John is being devious? The climax often reveals the conclusion or how the central conflict will be resolved.

Theme: The theme is the central idea or message of the literary work. The interplay of the characters, the plot, the setting, the language, and all other elements of literature can be used by a writer to persuade readers of a message. In presenting a theme, the author expresses an important idea about life or human nature. Certain themes are universal: They can be true at any time and in any place. Examples of universal themes are *love conquers all*; *hatred is destructive*; and *good triumphs over evil*. Writers do not always use these themes. Rather than present a story or play in which *good does triumph over evil*, they may present one in which the reverse occurs: *evil triumphs over good*. They may also play with universal themes and change *love conquers all* to *love conquers only the lover*.

Suspense: Suspense is a technique used to create uncertainty so the reader will stay interested in the story. Most writers create suspense by leading readers to ask questions. They present an initial picture to us—for example, a



374

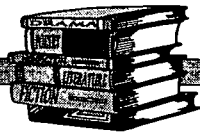

happy couple who answers the door to find a stranger. Then they urge us to ask questions: "What will this stranger bring into the happy couple's life?" When the stranger presents himself as a good and trustful person, the writer urges us to ask: "Is he really to be trusted, or is he deceiving the innocent couple?"

Narrator: The narrator is the speaker in a literary work. Two types of narrators are commonly used in literature.

A first person narrator is the teller of the story and is also a character or observer in the story. (Example: I will never forget the day I met Susan.)

A third person narrator tells the story but does not appear as a character in the story. (Example: As Tommy walked through the mall, he looked in all the store windows.)

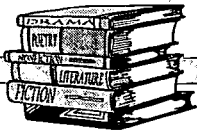

Practice

Match the **literary term** in the left-hand column with its **definition** in the right-hand column in each practice below. Write the correct letter on each line.

- | | |
|--------------------|---|
| ___ 1. protagonist | A. The sequence of events that takes place at the beginning, middle, and end of a work. |
| ___ 2. plot | B. The character that the reader wants to win. |
| ___ 3. climax | C. The person telling the story. |
| ___ 4. theme | D. The high point in the story that often tells us the end. |
| ___ 5. narrator | E. The central idea or message of the literary work. |
-

- | | |
|-------------------|---|
| ___ 1. antagonist | A. The time and place of a piece of literature. |
| ___ 2. conflict | B. A struggle between opposing forces. |
| ___ 3. suspense | C. A person or creature in literature. |
| ___ 4. setting | D. A technique used to create uncertainty and keep the reader interested. |
| ___ 5. character | E. The character that the reader wants to lose. |



Universal Themes: Ideas We All Live By

As you have already learned, the theme of a piece of literature is the idea the writer hopes to communicate to you. A *universal theme* is one that has generally been accepted by people in any country and at any time in history. Universal themes are those that speak of the human experience: feeling the various kinds of love; coming of age; choosing between right and wrong. You will discover as you read the literature of other cultures that certain feelings and certain situations have always occurred and will probably continue to occur as long as humanity survives.

Take a few minutes to think about the cycle of human life. Also, try to think of certain events and experiences that seem to recur. For example, countries seem to go to war time and time again, even though history has shown that it is destructive and cruel. Men and women fall in love and, as a result of this love, begin their own families. Parents love their children. Young people want to be free of their parents. Most everyone must, at some time or other, test his or her courage. These are some of the universal themes that you will find in literature.

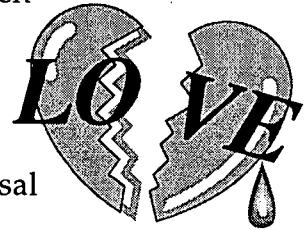

Perhaps one of the most universal of themes is the pain of lost love. Read the two prose poems that share this theme. Note how each writer uses this theme in a different way.

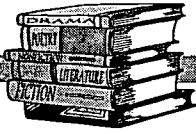

Loss Is the Name of My Loss

I had seen it happen to many of my friends. Their boyfriend or girlfriend went off, moved away, across the country or to another continent. I'd seen it happen before and thought, "They'll get over it. It's not the end of the world!"

And then it happened to me.

She was the part that made me whole. Now that she was no longer here, the world looked bleak. I sat in front of the TV for months afterward, feeling like my arm ended at the elbow, like I would be standing on my knees, if I ever got up. Then I forced myself to rise. I began to think that such a love would be tarnished if I let its loss end all worth. So I got up, went outside, day by day. And what I found was her. In the flowers, in the songs of birds, in the cry of a baby.

I made it through months, believing she was everywhere and the world was glorious. Until one day I heard a scream, an ugly scream far off, a scream of pain and loss. And then I knew that what I'd lost could never be replaced, not by flowers or birds or babies.

I knew then that loss is loss. It will not kill me or even tie me to my couch. It will be a pain that will hurt, at times.

And yet, if a wizard appeared and offered to take it away, I would yank his white beard and tell him: Loss is loss, for true loss cannot be lost.

—Unknown

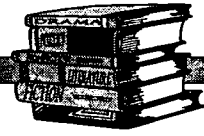

To Wonder Why

I knew it would end before it began. We were young and no matter how often or how intensely we declared our love to be forever, it would not last. No matter that I knew these things, for when it happened, I cried. I cried and I wondered why.

We sat together, my lost love and I, and we talked and even laughed about how high we'd soared on love. We remembered strolling through parks and seeing colors we never knew could exist. We remembered hearing new meanings in songs older than the trees. I asked him why our love had gone.

Suddenly we stopped talking and laughing and remembering. We just sat there in silence, no longer in love. I looked at him and he at me, and we both realized, as the silence spoke to us both, why our love was gone.

One day the colors had changed back. The songs no longer could be stretched to hold new meanings. The days returned to days, the nights to nights. And our love returned to the place it had come from. A dream place that I can no longer live in.

I sit and wonder why, now. Why I can't go and stay there, in that place? I begin to go to that place and something stops me. It is the earth I stand on, telling me my love must live here, where life is real, and I wonder if I should wonder why.

—Unknown

Reread each of the prose poems until you are familiar with what each is saying about the love each writer has experienced and has apparently lost.



Practice

Create and complete a **Venn diagram** like the example below that shows the differences and similarities between the two prose poems on pages 268 and 269. Notice that each circle stands for one of the poems. List the differences in the white and black areas. List the ways in which the two prose poems are alike in the overlapping gray area.

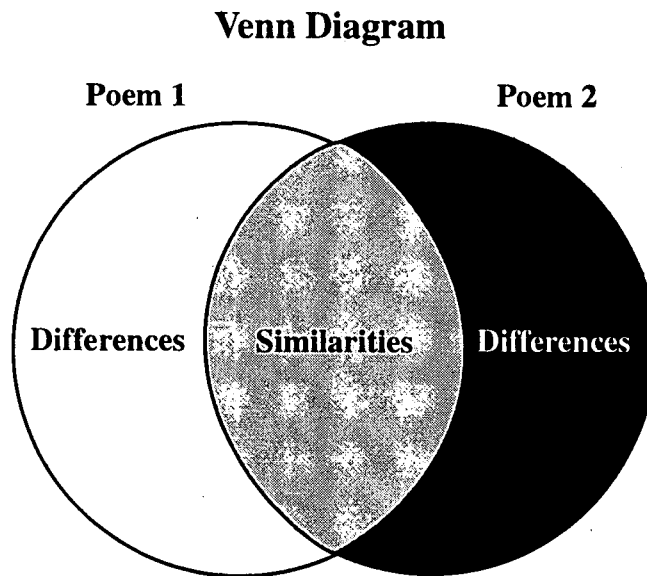

After completing the diagram, write an essay that explains the universal truth the prose poems discuss, how the two speakers' feelings are alike and different, and whether you share the feelings presented in the prose poems.

380



Application

*Locate and read other works that explore similar **themes**, even though the works may have been written in different times and in different cultures. Complete a **Venn diagram** comparing each pair of works read, and write an essay comparing the two works.*

The following are some suggested pairs:

“Through the Tunnel” by Doris Lessing and “Brothers Are the Same” by Beryl Markham

“The Writer” by Richard Wilbur and “Theme for English B” by Langston Hughes

“Everyday Use” by Alice Walker and “My Mother Pieced Quilts” by Terese Paloma Acosta

“Lalla” by Rosamund Pilcher and “Love Must Not be Forgotten” by Zhang Jie



Application

Provide the following explanations about a **story** that you have read recently. If you cannot remember a story you have read, ask your teacher to suggest one.

1. What is the title of the story? _____
2. Who is the author of the story? _____
3. What is the plot of the story? _____

4. Who is the narrator of the story? _____
5. Where is the story set? _____

6. In what historical period or time is the story set? _____

7. Name and describe the protagonist of the story. _____

8. Name and describe the antagonist in the story. _____

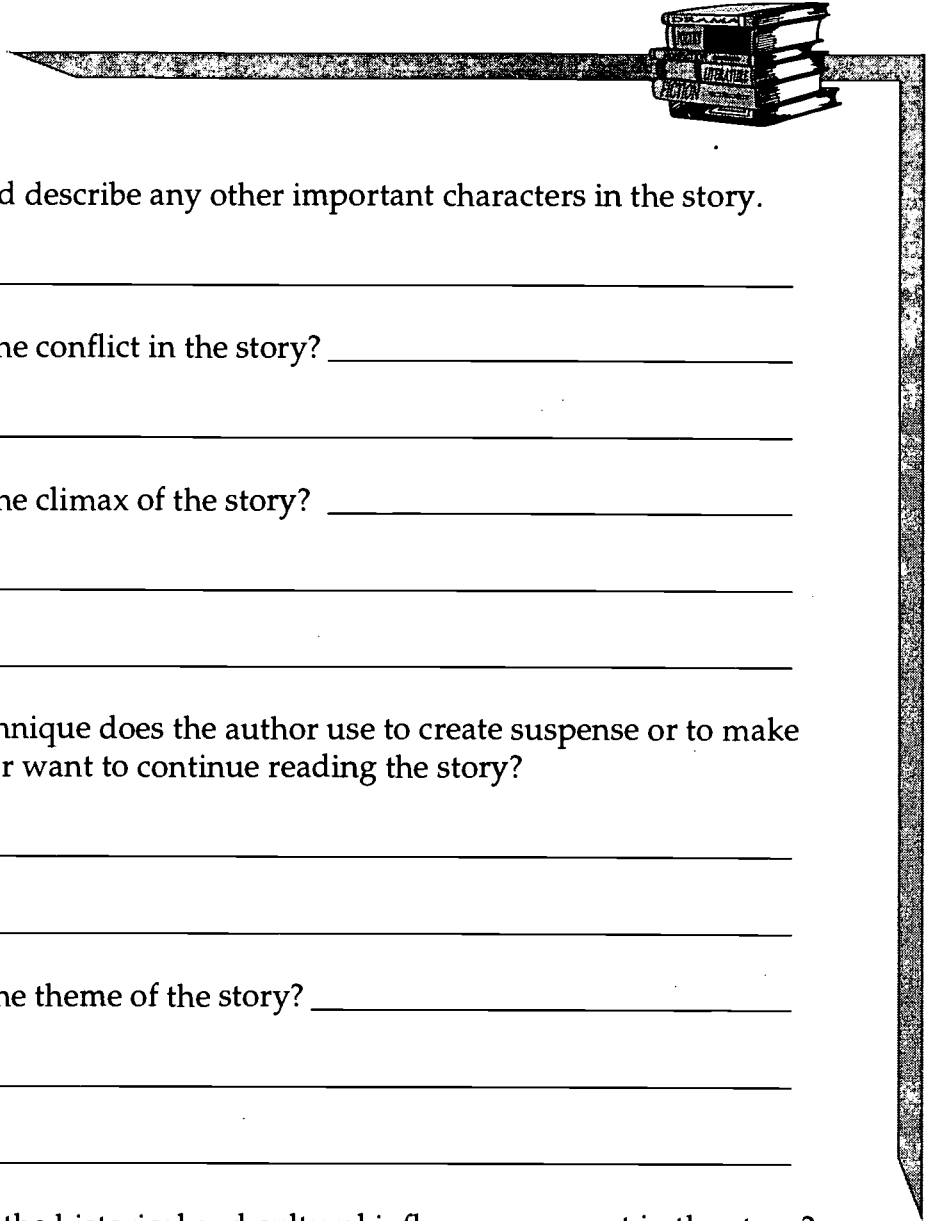

9. Name and describe any other important characters in the story.

10. What is the conflict in the story? _____

11. What is the climax of the story? _____

12. What technique does the author use to create suspense or to make the reader want to continue reading the story?

13. What is the theme of the story? _____

14. What are the historical and cultural influences present in the story?

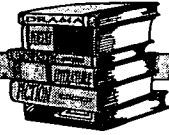

Short Story: Compressing the Conflict

The term *short story* can be deceiving because some short stories are quite long. There is no set length to short stories except that they are shorter than novels. A short story does, however, have certain distinct characteristics. Most short stories have a plot and a definite setting. A short story often centers around one climax and one major theme. Short stories can be narrated by a first or third person narrator.

Because a short story is so brief, more emphasis is placed on conflict than on character development. Usually, a short story contains one main conflict. This conflict involves the characters, keeps the story moving, and makes the story interesting. Conflict can be internal or external. *Internal conflict* occurs when an individual struggles within himself. *External conflict* occurs when an individual struggles against another person or force. We have all experienced conflicts. You may have had an internal conflict when you really wanted to do something but you knew you shouldn't do it. You may have had an external conflict when you got into an argument with your parents. The chart below gives examples of internal and external conflicts.

CONFLICTS	<i>Internal Conflicts</i> When an individual struggles within himself	<i>External Conflicts</i> When an individual struggles with another person or force
	<i>Will I do what I know is right, or will I give in to peer pressure?</i>	<i>Will I be able to reach the top of the mountain, or will the blizzard force me to turn back?</i>
	<i>Will I study to make grades, or will I let myself believe that grades aren't important?</i>	<i>Will I be able to persuade the jury that my client is innocent, or will my opponent persuade the jury that my client is guilty?</i>
	<i>Will I try to face failure, or will I refuse to try and avoid failure?</i>	<i>Will I be able to persuade society that the earth is round, or will society refuse to consider my evidence and go on believing that the earth is flat?</i>

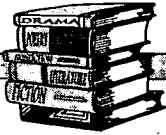

Practice

After reading one of the teacher-recommended short stories, answer the following questions.

1. What is the main conflict in this short story? _____

2. How does the author first introduce you to the conflict? _____

3. How is the conflict resolved in the story? _____

4. In your opinion, how else could the conflict have been resolved?



5. Explain how the author describes a main character of your choice by completing the form below with specific details from the story.

Name of Character:	
Method of Characterization	Specific Example
Appearance	
Speech	
Gestures/Movement	
Other Characters' Comments	
Relationships	
Habits/Work	
Thoughts/Values	



Novel: Fully Developed Characters Amidst a Host of Conflicts

Like short stories, *novels* are works of fiction. However, a novel is much longer than a short story. Because of its extended length, the novel develops and explores in more depth and detail all of the elements found in a short story. Most novels have a central plot that has subplots extending out from it. These subplots often have a beginning, middle, and an end, just like the central plot. Most novels have several conflicts going on during the course of the story rather than one predominant one, as in most short stories. Because novels are longer than short stories, the writer of a novel has more space to fully develop several characters and create settings that are rich in details. Novels often illustrate a theme in several ways or illustrate multiple themes.

The chart below shows the differences between a novel and a short story.

	Short Story	Novel
Conflict	one major conflict	more than one conflict
Plot	centers around one plot	centers around one major plot, but several subplots interweave throughout the novel
Characterization	develops one major character in a limited way	fully develops more than one character
Theme	usually contains one theme	often contains more than one theme
Setting	uses a few limited settings	uses many settings that are fully developed



Practice

Read the following descriptions and decide whether they would most likely be found in a short story, novel, or both. Write the correct answer on each line.

- _____ 1. The events described in the story are developed fully and cover a span of 100 years.
- _____ 2. The conflict in the story occurs when a young girl becomes jealous because her older sister is given a car.
- _____ 3. The story told is a work of fiction.
- _____ 4. The events described in the story take place in one day.
- _____ 5. The story told involves the problems a father has with his teenaged daughter, a similar problem the father's best friend is having with his son, and the difficulty his wife is having with her new job.
- _____ 6. The story follows a young man as he grows from childhood to adulthood and shows how he grows from a selfish child into a kind and generous old man.
- _____ 7. The intricate plot tells the story of a young man's arrival in America and goes into great detail about the problems he encounters and how they are resolved.
- _____ 8. The story illustrates how honesty is the best policy.
- _____ 9. The story takes place in 1896 in the wild, wild west.
- _____ 10. The only thing the reader knows about the character of this story is that he loves to race cars.



Practice

Create a **Novel Notebook** by dividing a notebook into four sections called Double-Entry Journal, Characterization, Vocabulary, and Reader Response. Use the following examples to guide you as you complete each section of your Novel Notebook.

Double-Entry Journal

A double-entry journal provides you with an orderly list of events in a novel and your reactions to each of these events. Use the example below as a model for your double-entry journal.

CHAPTER 1		
○	What I Read	What I Thought
○	<i>The gold rush caused trouble for dogs like Buck—big and strong with warm, long hair.</i>	<i>What kind of trouble? Do they steal the dogs?</i>
○	<i>Buck "rules" Judge Miller's ranch in the Santa Clara Valley.</i>	<i>Buck has it made!</i>
○	<i>Buck's father was a St. Bernard; his mother a Scottish shepherd.</i>	<i>This makes Buck big and strong. I guess this means he'll get in trouble. Will he be stolen? I hope not!</i>
○	<i>Manuel, the gardener's helper, steals and sells Buck in order to pay his gambling debts.</i>	<i>Judge Miller would be really mad if he found out Manuel stole Buck.</i>



Characterization: Drawing Characters

A *character web* shows how a character is developed by listing what the character does, says, and how he looks and feels. Below is an example of a web about John Thornton, a character in *Call of the Wild* by Jack London. Create a character web about a character in your novel and include it in the characterization section of your Novel Notebook.

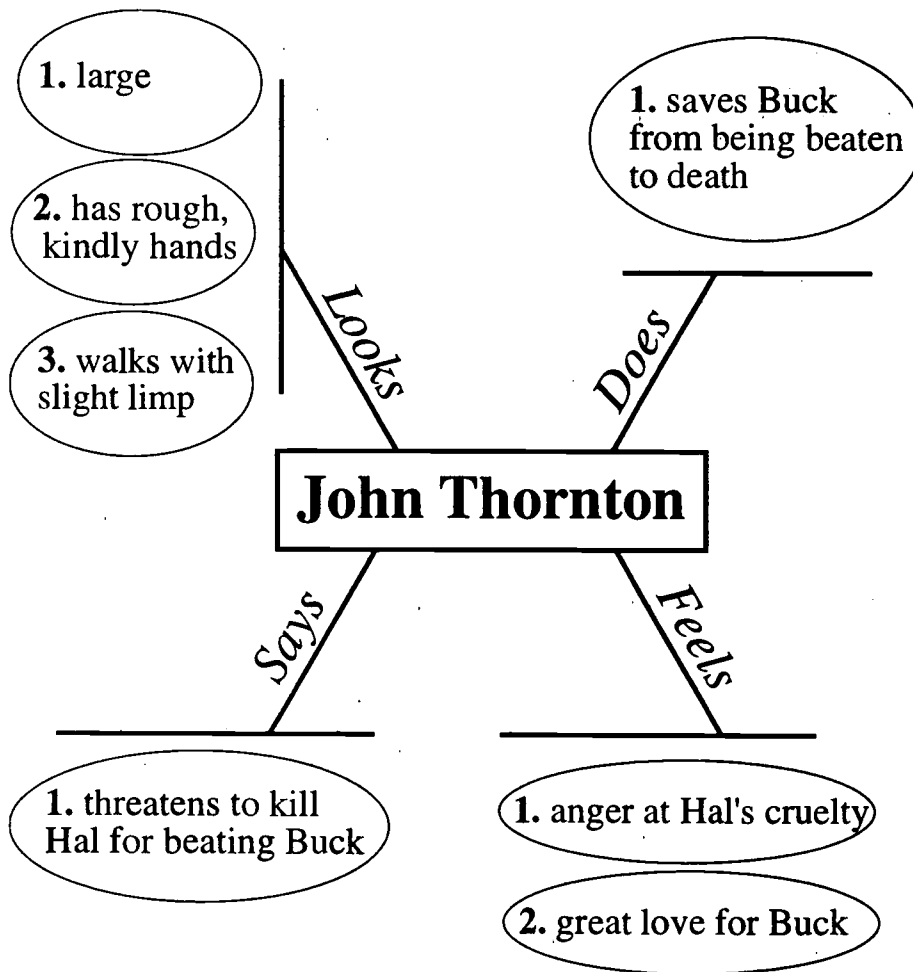

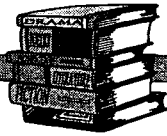

Vocabulary

The vocabulary section of the Novel Notebook is a place to record unfamiliar words and their definitions. Use the example below as a model for the vocabulary section of your Novel Notebook.

<input type="checkbox"/>	Vocabulary	Definition
	<i>lee</i>	<i>shelter</i>
	<i>salubrious</i>	<i>roughness</i>
	<i>recondite</i>	<i>hidden from sight</i>
	<i>pernicious</i>	<i>deadly</i>
<input type="checkbox"/>		
<input type="checkbox"/>		

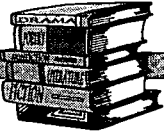

Reader Response

The Reader Response section of the Novel Notebook is a place to record your thoughts about and reactions to what you are reading. Use the example below as a model for the Reader Response section of your Novel Notebook.

<input type="radio"/>	<i>Reader Response</i>
	Title: <u>The Pearl</u> Author: John Steinbeck
	Chapter 1
	<i>This family has unusual names. They must be poor because their son doesn't have a baby bed and sleeps in the same room as his parents.</i>
<input type="radio"/>	<i>I think Kino really loves Juana. He thinks her eyes look like stars.</i>
<input type="radio"/>	

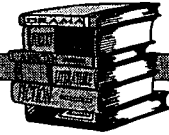

Practice

After reading one of the teacher-recommended novels, answer the following questions. Use your own paper if you need more space for your answers.

1. How do the protagonist and antagonist compare and contrast?

2. What is the conflict or conflicts in the novel? _____

3. When does the climax occur in the novel? _____

4. How does the setting (place, time, culture) influence the story and the characters' choices?

5. What is the theme(s) of the novel? _____

6. How does the theme relate to your life? _____

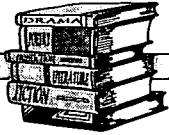

7. What three questions would you like to ask the author of this novel?

8. Select one of the characters from the novel you have read, and use the chart below to gain a greater understanding of the character.

Name of Character:	
Question	Answer and Explanation
1. What color would best represent the character? Why?	
2. What animal would best symbolize the character? Why?	
3. What season would best symbolize the character? Why?	
4. What geographical location would best symbolize the character? Why?	
5. Where would you take this character on a date? Why?	
6. Which three adjectives would best describe this character's strengths?	
7. Which three adjectives would best describe this character's flaws or weaknesses?	



Application

Select one of the following **topics** to write about. Use the information in your *Novel Notebook* to help you.

1. Choose a character you find interesting. Write an essay that explains why this character behaved as he or she does.
2. Explain a conflict you found in the novel. Be sure to explain the characters and/or forces involved in this conflict. How is this conflict resolved? Also, describe a time when you found yourself in a similar situation. How did you resolve the conflict? What forces in your life (time and place in which you live) influenced how you resolved the conflict?
3. Explain how the beginning of the story suggests the conflict that occurs in the middle of the story. In addition, describe what questions the writer urges the reader to ask.



Poetry: Tasting Words

Poetry is literature that uses carefully selected language to create a feeling, thought, or understanding in the reader. The poet uses words to make the reader see, taste, hear, or feel the subject of the poem. Poems can be long or short; rhythmic or not. Some poems rhyme and others don't. Some poems look like paragraphs while others are in the shape of whatever the poem is about! Poems can tell stories, present a series of sounds, or describe a beautiful picture. Poems can also help us see old or common things in a new way.

Reading poetry aloud is really the only way to fully appreciate poetry. You should hear each—actually *taste* each word—in a poem. Because a poem generally has fewer words than a short story or novel, each word in a poem is very important. Poets select their words carefully because each one adds to the overall meaning of a poem. The words in a poem work together to create a sensory experience through their sound, look, or symbolic meaning. The following terms are used to describe language techniques that poets and other writers use.

Metaphor: A metaphor compares two unlike things. *Example:* "The school was a beehive of activity." "When I was trapped in my house, my telephone was my umbilical cord to the world." As you can see, metaphors exaggerate to make a point. Schools are not beehives but they can seem almost as busy—especially just before the bell rings! Similarly, a telephone does not provide one with nourishment, as an umbilical cord does for a baby. However, a telephone will provide access to a kind of nourishment, such as friendship and conversation.

Simile: Simile is a comparison between two different things that uses the word *like* or *as*. *Example:* "My love is *like* a red, red rose."

Personification: Personification is giving human qualities to an object, animal, or idea. *Example:* "the sky is crying"; "the daffodils danced in the wind."

Rhyme: Rhymes are words which sound alike and are at the end of each line. *Example:* "shine" and "mine" rhyme.

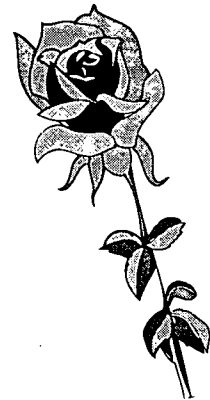



Rhythm: Rhythm is a pattern of beats based on stressed and unstressed syllables. When you go to the beach and listen to the waves ride into shore and then fade, you are listening to the rhythm of the waves. Each time you speak you are using rhythm. Your voice rises and stresses certain words, and lowers and does not stress other words. In poetry, rhythm is the pattern of sound in a poem.



Example: Nōr yēt ā floatīng spār tō mēn thāt sīnk
 Ānd rīse ānd sīnk ānd rīse ānd sīnk āgāin;
 (Edna St. Vincent Millay)

Read the following poem at least twice aloud. What do you think the poem says?

The Art of Being Me

If I could find a witty phrase to say,
When told to do and not to play,
If I could be as sharp as art,
My words would go right to the heart.
If I could be just so and stand up straight,
Tell others words so filled with hate,
I would be what others had made
And real me would have been slayed.

—Unknown

The first step in understanding a poem is to summarize it. Put in your own words a description of the actions or statements found in the poem. The following is a summary of "The Art of Being Me."

The poem "The Art of Being Me" is about a speaker who wants to answer everyone who tells him what to do. He wants to respond to others in a sarcastic or biting way and hurt their feelings. But he knows that saying such words would only turn him into something he is not—he is not hateful. He realizes that if he lets others bother him, he is letting them take control of his feelings. If he lets others gain control of his feelings, then his real self will die.

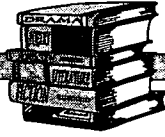

The second step is to gain an understanding of how the poem works. How does the poem use language—metaphors, similes, personifications, rhymes, and rhythms—to make its point powerfully in a few words?

Here is the poem presented again with the lines numbered and an analysis below.

The Art of Being Me

- (1) If I could find a witty phrase to say,
- (2) When told to do and not to play,
- (3) If I could be as sharp as art,
- (4) My words would go right to the heart.
- (5) If I could be just so and stand up straight,
- (6) Tell others words so filled with hate,
- (7) I would be what others had made,
- (8) And real me would have been slayed.

The poet uses both metaphor and simile to make powerful points in just a few words. “If I could be as sharp as art” (line 3) is a simile because it compares two things (*I* and *sharp as art*) using the word *as*. The word *art* is being used here in an unusual way. Here is where a dictionary can be helpful. The word *art* can refer to tricks and devices. The speaker would like to use tricky phrases to answer back those who give him orders. He wants those tricky phrases “to go right to the heart” (line 4). Of course, words do not actually go to someone’s heart. Here he is using the *heart* as a metaphor. The *heart* is a symbol of the place where we feel things deeply. He wants his tricky phrases to sting and hurt.

Another metaphor he uses is “stand up straight” (line 5). The speaker does not literally mean he would straighten his posture. He is, instead, suggesting that he would be aggressive towards others who give orders, rather than being shy and reserved. Shy and reserved is what he really is, and to be otherwise would mean he had “slayed” (line 8) his true self. Slayed is also used as a metaphor, for surely he would not actually kill a part of himself. Notice the poet’s unusual use of the word *slayed*. The past tense of *slay* is *slew*. By using the word *slayed* instead,

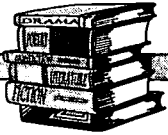

the poet not only makes it rhyme with “made” (line 7), he also calls attention to this most important word.

The rhyme of this poem is easy to identify:

- (1) say (*a*)
- (2) play (*a*)
- (3) art (*b*)
- (4) heart (*b*)
- (5) straight (*c*)
- (6) hate (*c*)
- (7) made (*d*)
- (8) slayed (*d*)

We would describe this rhyme in the following shorthand: *aabbccdd*. The words that rhyme in a poem receive extra emphasis. A word points to or hooks to another word with which it rhymes. Rhymed words cast a light on one another. If you look at just the rhymed words in this poem, you will notice that they very nearly tell the thesis of this poem. The speaker would like to *say* something to those who would deny his *play*; he wants to use *art* to hurt their *hearts*, but such *hate* would *slay* his true self.



Practice

Read the following *poems* and answer the questions that follow.

E. E. Cummings (1894-1962)

II

Humanity i love you
because you would rather black the boots of
success than enquire whose soul dangles from his
watch-chain which would be embarrassing for both

parties and because you
unflinchingly applaud all
songs containing the words country home and
mother when sung at the old howard*

Humanity i love you because
when you're hard up you pawn** your
intelligence to buy a drink and when
you're flush*** pride keeps

you from the pawn shop and
because you are continually committing
nuisances but more
especially in your own house

Humanity i love you because you
are perpetually putting the secret of
life in your pants and forgetting
it's there and sitting down

on it
and because you are
forever making poems in the lap
of death Humanity

i hate you

© Marion M. Cummings reprinted by permission of Liveright Publishing.

* The *Old Howard* was an old theater in Boston, Massachusetts.

** To *pawn* means to use something as security in exchange for a loan.

*** *Flush* means having a lot of money.



92

i carry your heart with me(i carry it in
my heart)i am never without it(anywhere
i go you go, my dear; and whatever is done
by only me is your doing, my darling)

i fear

no fate(for you are my fate, my sweet)i want
no world(for beautiful you are my world, my true)
and it's you are whatever a moon has always meant
and whatever a sun will always sing is you
here is the deepest secret nobody knows
(here is the root of the root and the bud of the bud
and the sky of the sky of a tree called life; which grows
higher than soul can hope or mind can hide)
and this is the wonder that's keeping the stars apart

i carry your heart(i carry it in my heart)

© Marion M. Cummings reprinted by permission of Liveright Publishing.



Nikki Giovanni (b.1943)

The Funeral of Martin Luther King, Jr.

His headstone said
FREE AT LAST, FREE AT LAST
But death is a slave's freedom
We seek the freedom of free men
And the construction of a world
Where Martin Luther King could have lived and
preached non-violence

© 1968 Nikki Giovanni by permission of author

Knoxville, Tennessee

I always like the summer
best
you can eat fresh corn
from daddy's garden
and okra
and greens
and cabbage
and lots of barbecue
and buttermilk
and homemade ice-cream
at the church picnic
and listen to
gospel music
outside
at the church
homecoming
and go to the mountains
with your grandmother
and go barefooted
and be warm
all the time
not only when you go to bed
and sleep

© 1968 Nikki Giovanni by permission of author



Kidnap Poem

ever been kidnapped
by a poet
if i were a poet
i'd kidnap you

put you in my phrases
and meter you to jones beach
or maybe coney island
or maybe just to my house

lyric you in lilacs
dash you in the rain
alliterate the beach
to complement my see

play the lyre for you
ode you with my love song
anything to win you
wrap you in the red Black green
show you off to mama

yeah if i were
a poet i'd kid
nap you

© 1968 Nikki Giovanni by permission of author



Poetry

poetry is motion graceful
as a fawn
gentle as a teardrop
strong like the eye
finding peace in a crowded room
we poets tend to think
our words are golden
though emotion speaks too
loudly to be defined
by silence

sometimes after midnight
or just before the dawn
we sit typewriter in hand
pulling loneliness around us
forgetting our lovers or children
who are sleeping
ignoring the weary wariness
of our own logic
to compose a poem
no one understands it
it never says "love me" for poems seek not
acceptance but controversy
it only says "i am" and therefore
i concede that you are too

a poem is pure energy
horizontally contained
between the mind
of a poet and the ear of the reader
if it does not sing discard the ear
for poetry is song
if it does not delight discard
the heart for poetry is joy
if it does not inform then close
off the brain for it is dead
if it cannot heed the insistent message
that life is precious

which is all we poets
wrapped in our loneliness
are trying to say

© 1968 Nikki Giovanni by permission of author

404

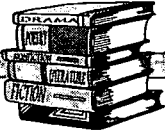

1. How are poems different from other genres of writing you've read?

2. What does poetry have in common with other genres you've read?

3. What is unusual about the way E. E. Cummings writes? _____

Why do you think he writes this way? _____

4. What is a theme of E. E. Cummings' poem "II"? _____

5. In E. E. Cummings' poem "92," who might the speaker be addressing besides a person?

6. What is the meaning of one metaphor or simile used by Nikki Giovanni in any of her poems?



7. What is one possible purpose and one possible audience for the poem "The Funeral of Martin Luther King, Jr."?

Support your answer with evidence from the poem. _____

8. What does summer symbolize to the speaker in Nikki Giovanni's "Knoxville, Tennessee"?

9. What is your favorite line from any of these poems? Explain why you like it, or use it as the first line for your own poem.

10. Finish this sentence. Poetry is... _____



11. What do you think a poem can do for and to a reader that a short story or novel cannot?

407

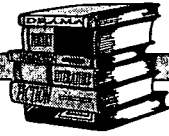

Drama: A Story Told by Actors in Action

Any piece of writing that is meant to be performed by one or more actors in front of an audience is classified as *drama*. There are several different types of drama. Most high school students find themselves concentrating on three major types of drama. One type of drama is a play that can be called serious or realistic drama. This is referred to simply as *drama*. A second type of drama is *tragedy*, and a third type is *comedy*.

Most drama is divided into *acts*. An act is like a chapter in a novel because it divides up the play into units of action. Acts are sometimes divided into *scenes*—a single time and place. All plays include instructions called *stage directions* that give guidelines to the director, actors, readers, and stage crews about how the play should be presented. Stage directions are usually printed in italics and are often enclosed in parentheses or brackets. Stage directions describe the following:

- the scenery or setting of a play
- the props—objects, furniture, and other property—that are used during the performance
- lighting used during the play to give special effects
- music and other sound effects to add to the overall realism and mood of the play
- costumes worn by the actors that are appropriate for the play's setting and actions
- specific actions or movements for the actors

Realistic Drama: Lifelike Characters and Lifelike Problems



Realistic dramas are not really tragedies because they often have happy endings. They are not comedies because they focus on serious life problems. Dramas are about realistic people who are faced with real-life problems. The action of the play revolves around how these characters respond to these problems.

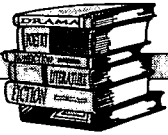

Practice

After reading one of the teacher-recommended dramas, answer the following questions.

1. How many acts and scenes does the play have? _____

2. In a single sentence, summarize the events that occur in each act.

3. What is the conflict (or conflicts) in the play? _____

4. In which act and scene does the climax occur? _____

5. How are the antagonist and protagonist alike? _____



6. How are the antagonist and protagonist different? _____

7. What is the theme (or themes) of the play? _____

8. How is this theme relevant to our society? _____

9. If you were asked to act in this play, which character would you choose to portray?

Why? _____

10. How would you briefly describe the character you chose?

11. If you were asked to direct this play, what message would you like the audience to receive by the end of the performance?

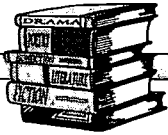

Practice

A **Spider Map** is one way to graphically illustrate the main points in a piece of literature. The body of the spider is the title, the legs are the four common elements found in literature, and the lines coming off the legs are the details related to each element. Study the completed spider map below. This map is an analysis of the play entitled *Trifles* by Susan Glaspell. Notice that the characters in the play are listed on the lines that are perpendicular to the "character" line, the main events are listed on lines that are perpendicular to the "plot" line, and so forth. Complete the blank spider map on the next page with details from the drama you read.

Spider Map

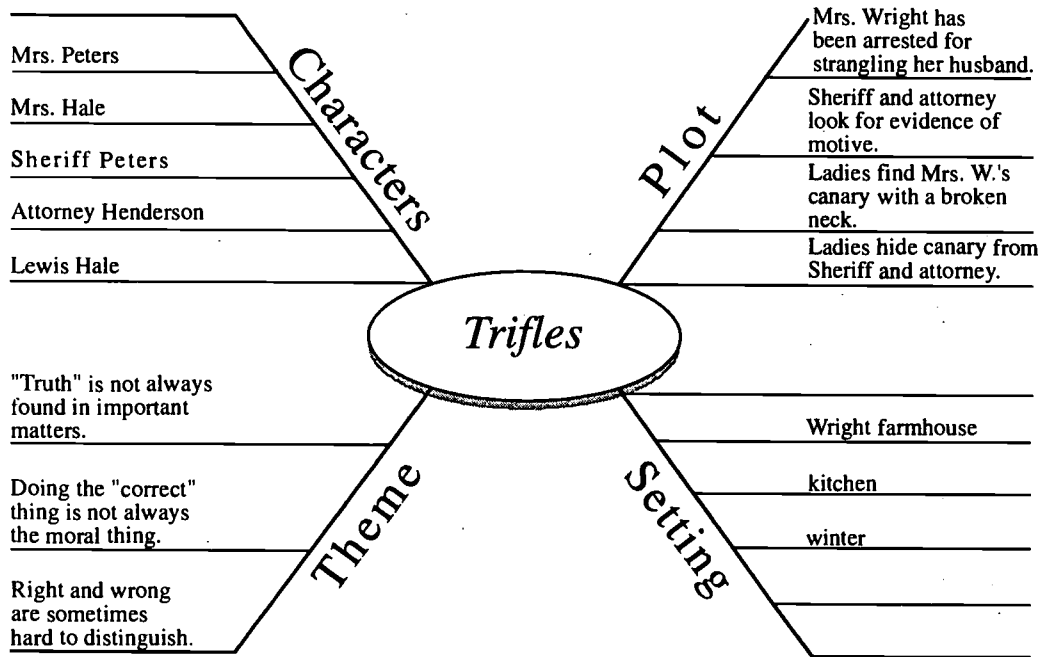



Spider Map

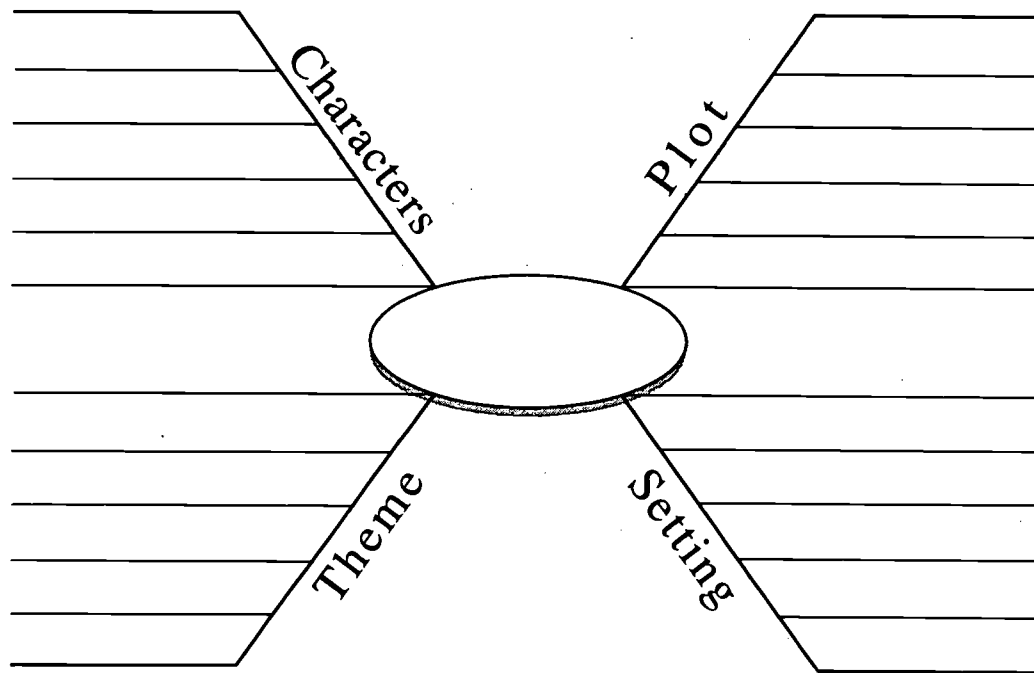



Tragedy: When the Worst Happens to the Best

A *tragedy* is a type of drama that shows the downfall of a heroic character. A tragedy usually features a catastrophe that leads to the ruin of the protagonist. A tragedy follows a definite pattern of events.

- A good person, often a person of noble birth, goes from happiness to ruin. This person is called the *tragic hero*.
- The tragic hero possesses a weakness that causes his downfall. The weakness is called a *tragic flaw*.
- When the character realizes he is ruined, he also realizes that he is responsible for his own destruction.
- The tragic hero's destruction is complete, and he can never recover his original state of happiness.
- Members of the audience are overcome with pity for the tragic hero and with fear that they too might have a tragic flaw leading to their downfall. The audience's emotional response to the tragedy is called *catharsis*.
- The tragic hero suffers, but he does so with dignity. In the face of his tragedy, the tragic hero shows some of the human qualities we admire.





Practice

Read one of the teacher-recommended **tragedies**, and answer the following questions.

1. A tragic hero must be a good person, and often is of noble birth. In what way(s) is the protagonist of this tragedy a good and/or noble person?

2. The tragic hero must begin the play as a happy or lucky person. In what way(s) is the protagonist of this tragedy happy or lucky?

3. What is the protagonist's *tragic flaw*? _____

4. In what way does this tragic flaw lead the protagonist to cause his own destruction?

5. At the end of a tragedy, the protagonist's destruction must be complete. How is the protagonist of this tragedy completely destroyed?

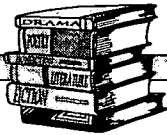

6. Use the chart below to gain a greater understanding of the *tragic hero* of this play.

Name of Character:	
Question	Answer and Explanation
1. What color would best represent the character? Why?	
2. What animal would best symbolize the character? Why?	
3. What season would best symbolize the character? Why?	
4. What geographical location would best symbolize the character? Why?	
5. Where would you take this character on a date? Why?	
6. Which three adjectives would best describe this character's strengths?	
7. Which three adjectives would best describe this character's flaws or weaknesses?	



Application

Use your own paper to complete a **character map** like the one below. Notice how the example below shows you how the tragic hero of this play went from a state of happiness to a state of ruin. Begin your map with a description of the character at the beginning of the play, and end with a description of the character as the play ends. Chart the sequence of events in between that leads to the tragic ending.

Romeo and Juliet

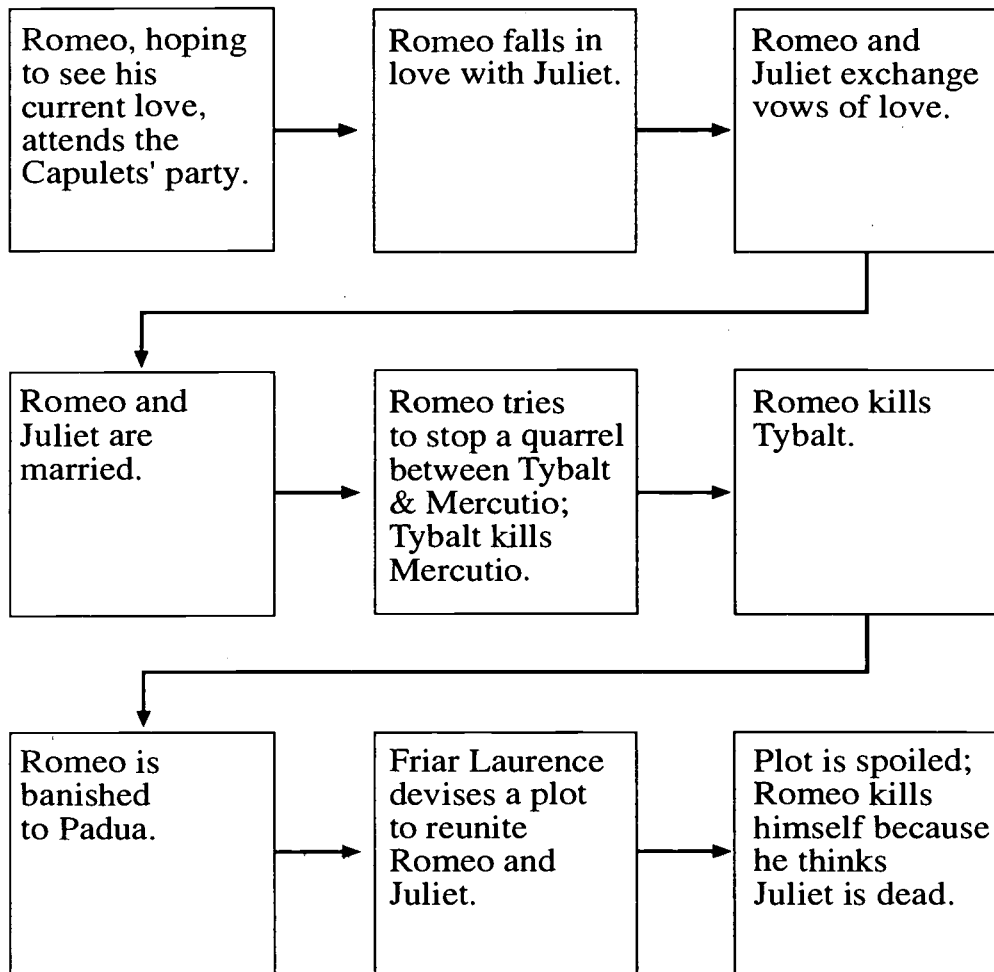

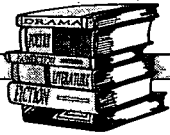

Comedy: Celebrating Life, Celebrating Laughter

A *comedy* is drama that is light, funny, and usually has a happy ending. Some comedies are romantic comedies, which depict lovers who must overcome all kinds of difficulties in order to be together. Romantic comedies often end in a huge wedding celebration that not only celebrates a new beginning but also life itself. Shakespeare originated the romantic comedy, but we see many of them today on television and in movie theaters.

Farce is drama that is funny because of ridiculous situations, unrealistic characters, and physical behaviors. Characters are often stereotypes with a single character trait that is exaggerated to the extreme. These characters often do bizarre things that most normal people probably wouldn't do in real life unless they were doing it as a joke. A farce often uses low comedy—humor that involves physical action. Low comedy is used in cartoons and movies. A character tripping over a chair, slipping on a banana peel, or throwing a pie at someone are examples of low comedy.



Although we go to comedies to smile and laugh, this type of drama often gives us much more. Comedies frequently show us the humor behind our daily lives. For example, a young man who is meeting his girlfriend's parents for the first time won't think it is funny if he discovers he has poppy seeds stuck in his teeth or realizes that he has on one black sock and one brown sock. If you are watching a comedy that includes a scene like this you might think it is funny because you can identify with the character but are removed from the actual situation. Being able to identify with comedic situations while not being directly involved helps us look at our human qualities and see the underlying humor.

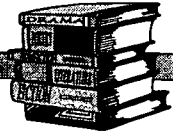

Practice

After reading one of the teacher-recommended comedies, answer the following questions.

1. How many acts and scenes does the play have? _____

2. In a single sentence, summarize the events that occur in each act.

3. What is the conflict (or conflicts) in the play? _____

4. In what act and scene does the climax occur? _____

5. How are the antagonist and protagonist alike? _____

6. How are the antagonist and protagonist different? _____

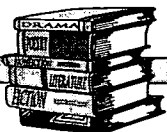

7. How does this play fit the definition of a *comedy*? _____

8. Choose two situations or events that you thought were funny and explain why.

9. If you were asked to act in this play, which character would you choose to portray?

Why? _____

10. How would you describe the character you chose?

11. If you were to direct this play, what message would you like the audience to receive by the end of the performance?

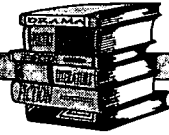

Application

Select the **protagonist** from a tragedy that you have read and one from a comedy that you have read. Complete the chart below to compare these characters.

Characteristics	Tragic Protagonist	Comic Protagonist
Situation at Beginning of Play		
Conflict Encountered		
Resolution of Conflict		
Situation at Conclusion of Play		

Now write a paragraph in which you analyze the differences between the tragic protagonist and the comic protagonist.



Autobiography and Biography: Stories about a Life

Autobiographies and *biographies* are nonfiction and tell the true stories of a person's life. An autobiography is the story of a person's life written by himself. Autobiographies are told from the first-person point of view—the writer uses the pronoun *I* to refer to himself in the story. In an autobiography, the author tells about the major events in his life, and how he felt and what he thought about those events. Journals, diaries, and letters are all examples of short autobiographical narratives. Other autobiographies are very long because they cover the major events over an entire lifetime.

A biography is the story of a person's life told by another person. Biographies are told from the third-person point of view—the writer uses the pronoun *he* or *she* to refer to the subject of the story. It is important for the author of a biography to use factual information in her writing. These facts usually come from interviews and in-depth research about the life of the subject. Many biographies have been written about famous people after they have died. Biographers must be very careful to use research that is reliable so the facts they present are accurate. Some famous people hire biographers to write their life's stories while they are still alive so they know for sure that what is written is true.

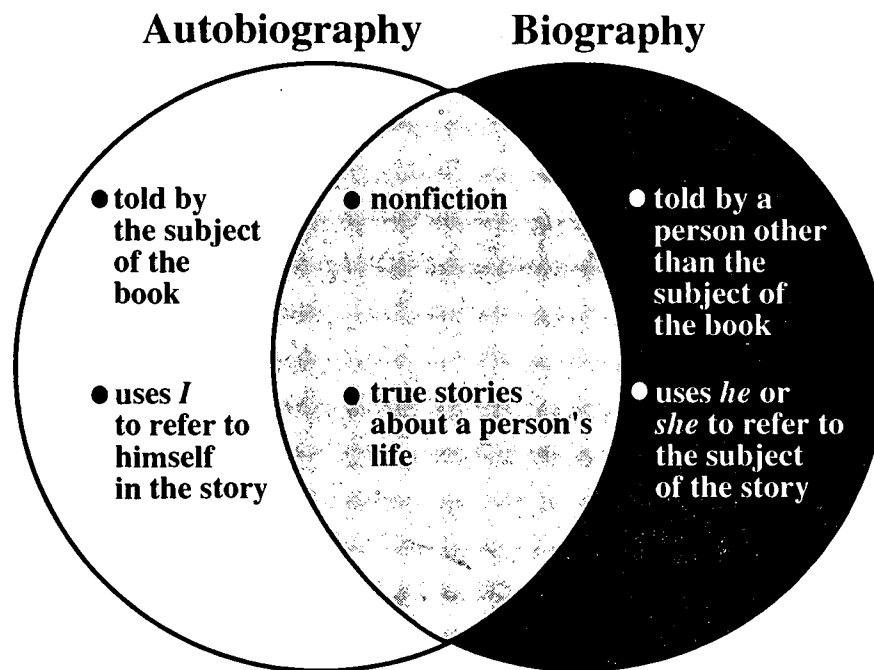

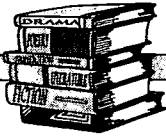

Practice

Complete the following web with characteristics of an **autobiography** and a **biography**.

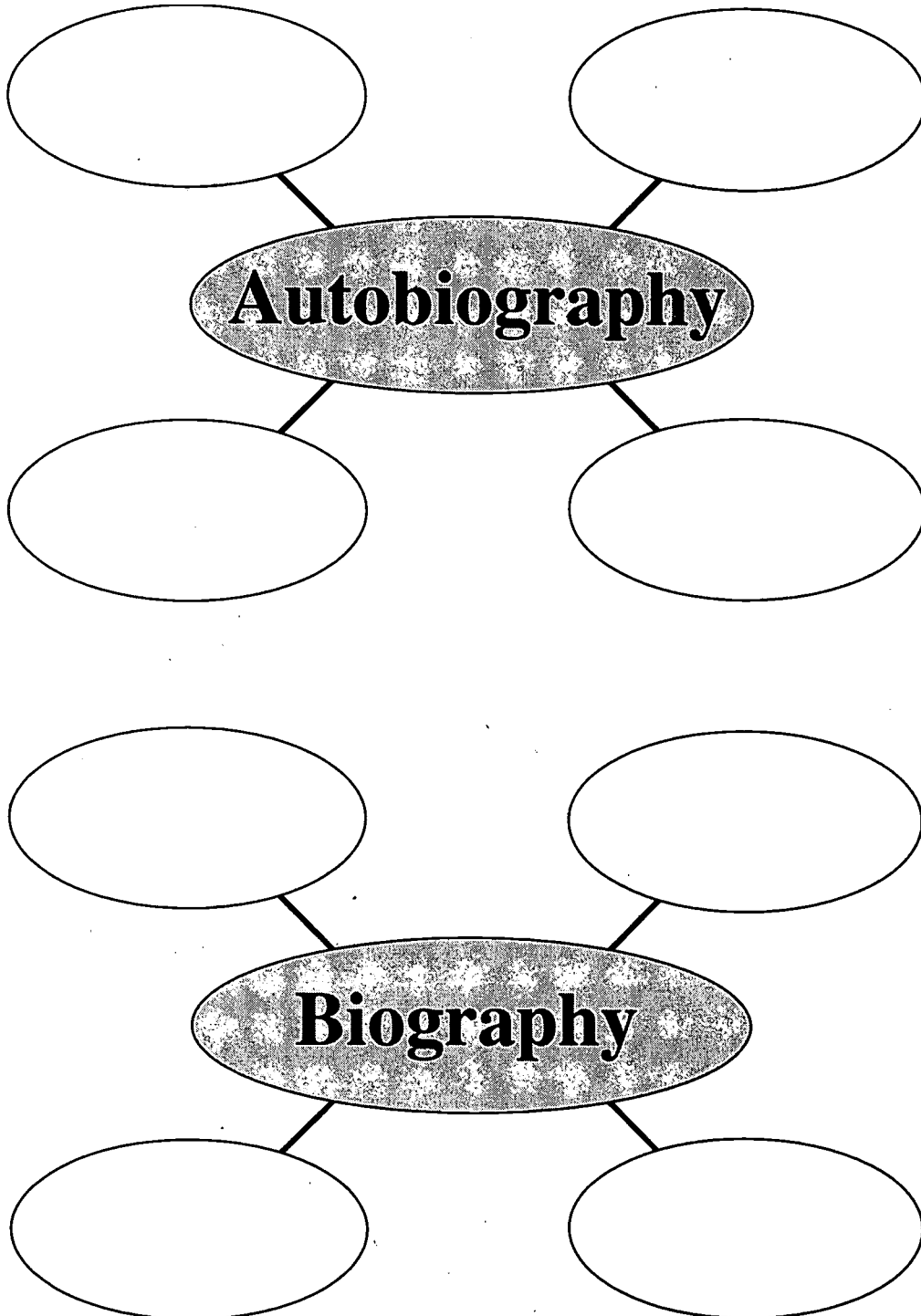

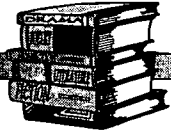

Application

After reading a teacher-recommended **biography or autobiography**, answer the following questions.

Title: _____ Author: _____

Biography or Autobiography: _____

1. What conflicts or struggles does the subject of the biography or autobiography face?

2. How does the subject overcome or resolve these conflicts? _____

3. What climactic moments does the subject experience? _____

4. How do these climactic moments change the subject? _____

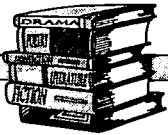

5. Does the writer seem to exclude any important information? If so, what, and why do you think he or she did this?

6. What lessons can the subject's life teach you personally? _____

7. Why do you think the biographer chose to write about this person? Or, if you read an autobiography, why do you think the autobiographer chose to write about his or her own life?

8. What questions would you like to ask the subject of the biography or autobiography?

9. If you could write a biography about anyone living or dead, famous or ordinary, who would you choose and why?



Critical Analysis: Examining the Parts to Judge the Whole

Once you can identify the characteristics of various kinds of literature and are familiar with examples of each, you are ready to evaluate what you have read. When you *evaluate* something, you actually make decisions about how good the thing you are judging is. A judge at a state fair gives a blue ribbon to a cow after he has evaluated all the cows and decided which one is the best. He makes his decision by judging the quality of each cow. You have probably judged the quality of many things in your lifetime—a haircut, the latest CD of your favorite group, or the fairness of a grade.

One way to evaluate something is to do a *critical analysis*. When you critically analyze something, you take it apart and decide which parts meet your standards and which parts do not meet your standards. Even though you may not realize it, you are using a set of characteristics to guide your evaluation.

Use the following steps to help you complete a critical analysis:

- Identify what you are critically analyzing. *Is the item a short story, a novel, a tragedy or comedy, an automobile, etc?*
- Develop a list of the characteristics of quality, or criteria, you will use to analyze and evaluate the item. *To analyze a tragedy, you would probably use criteria that included whether the tragic hero was noble and whether his downfall was complete.*
- List the characteristics of quality, or criteria, in order of importance. *Your most important criterion for a tragedy might be whether you believe the hero's tragic flaw caused his destruction. In contrast, the most important criterion for a comedy might be whether it is funny.*
- Apply the criteria to the things you are judging. *If the item being evaluated fulfills a criterion, or characteristic, place a mark in the favorable column. If not, choose unfavorable or neutral.*



- If you are comparing two or more items, decide which of the items has the most characteristics. *Add the number of marks in each column.*
- Write a conclusion that supports your decision.

The following is an example of a critical analysis of "The Most Dangerous Game" by Richard Connell.

Type of Work: Short Story

Title: "The Most Dangerous Game"

Author: Richard Connell

Criteria

	Favorable	Unfavorable	Neutral
Story has an appropriate surprise ending.	X		
Story is filled with suspense and action.	X		
Story appeals to readers our age.	X		
Story is easy to read.		X	
Story has a worthwhile theme.			X
<p>The story "The Most Dangerous Game" met my top criteria. Although I found the story somewhat difficult to read, this single unfavorable characteristic did not lessen my desire to find out how the story would end. I found the theme commonplace, but other readers who have had different life experiences than I might find the theme worthwhile.</p>			



Practice

Use the blank evaluation matrix below to help you complete a critical analysis on one of the following subjects: your favorite musical group, your favorite car, or your favorite movie.

Subject: _____

Criteria	Favorable	Unfavorable	Neutral

Conclusion: _____

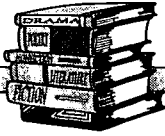

Application

A blank evaluation matrix is given below. You can use it for any work of literature you have read. Ask your teacher for help in determining your criteria and how you would rank them.

Title: _____

Author: _____

Criteria

	Favorable	Unfavorable	Neutral

Conclusion: _____

Unit 6: Integrating Online Technology— Using the Information Highway

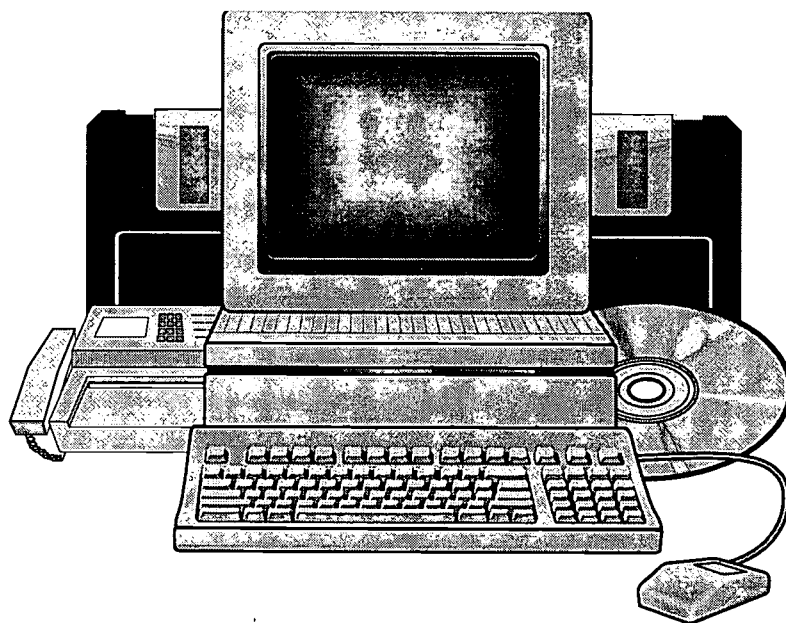



Unit 6: Integrating Online Technology—Using the Information Highway

Overview

At one time it was the telephone. Then it was the television. When these technological gadgets first hit the market, most people thought they would never become household items. They were just a passing fancy. Nothing could have been further from the truth. The telephone and television have become so common that indeed we are surprised when we don't find both of them in someone's home. In fact, we may be surprised if we don't find two telephones and televisions in someone's home.

So it was with the computer during its infancy in the 1960s. Few people had the foresight to imagine that computers would become a common and necessary part of our everyday lives. Try to imagine all computers being gone, starting with personal computers to the incredibly powerful computers that run our country's telephone systems. Imagine how our lives would change in a flash!

Computers and online technology have given us access to a wealth of materials, including articles, texts, and other documents. In the past, your research for a school project would have been limited to the contents of your local libraries. You could have gotten documents from distant libraries, but the process would have taken weeks, at least. Today you can get many research articles and books in the time it takes to get on the Internet, locate the document, download, or view it. Often, the process can be done in a matter of minutes. In this unit you will learn how to find documents you want on the Internet.

Computers and online technology have also helped us create a new mail system. In a matter of seconds you can send a message on the Internet to any other computer system that is online. You can be anywhere and read the mail, even on vacation or at the beach. Sending a letter from Florida to California over the Internet takes seconds, just a few strokes of the keys and a few clicks of a mouse, as you will learn in this unit.



Like all technology, computers and online technology can be used for good and productive purposes or can be used to waste time. The knowledge you gain in this unit will help you operate on the information highway. What you do once you're on the Internet is up to you. Use it wisely and responsibly.



Vocabulary

Study the vocabulary words and definitions below.

- Boolean wording** specific words or symbols used to narrow down a topic search on the Internet
Examples: or, and, not, "+", and "-"
- button bar** a bar with icons or pictures to click on that perform different functions
- document** written information
- electronic reference** the source and location of reference information obtained from the Internet or electronic means
- gopher** a text-based application for finding specific information on the Internet (used for older document management systems)
- Internet** a collection of computer networks to view, retrieve, or share information from around the world
- Internet address** the electronic address used to access a specific site
- menu** a collection of related commands or applications



- MLA style written procedures used to write papers and resources

- search engine a tool used to find specific references or websites on the Internet

- web page a site on the Internet with its own address; may provide information or links to other sites

- window a graphic method of interacting with a computer program to open its applications



The Information Highway: A New Mode of Travel

The Internet is a collection of computer networks. A good way to think of this is to imagine your telephone system. From your phone, you can dial up and contact any other phone in the world. The Internet permits you to use any computer with the right program to connect with any other computer or database that is also programmed

for such a connection. This connection can occur through phone lines, cable systems, or directly wired access. The Internet allows users to view, retrieve, or share information with other users around the world. The use of the

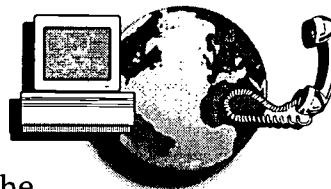

Internet allows you access to information that is current, ever-changing, and not limited to resources available within the school setting. However, like the information you get from a book or other resources, information from the Internet should be checked for accuracy and appropriateness.

The Internet opens many doors to educational opportunities that were never before possible. Users can communicate with peers and/or mentors around the world. They can interview authors or witnesses to actual events and then write about the experiences. Internet users can also get up-to-date current events and contemporary literature before it comes out in printed material. The Internet also provides you with the opportunity to publish and share your own work, as well as to collaborate on projects with people on the other side of the world.

The Internet has its own language—terms and phrases that are used to describe applications and other items common to this system. Words or phrases that are underlined are defined within this list.

Browser: A software program on an individual machine (computer) that is used to view various Internet resources. Netscape is an example of a web browser.

Electronic Mail (e-mail): Messages, usually text, sent from one person to another via computer. Pictures and files can be sent as attachments to be viewed by other programs. E-mail can also be sent automatically to a large number of **Internet addresses** (Mailing List).

File Transfer Protocol (FTP): A common method of moving files between two computers. FTP is a special way to log on to another Internet site for the purpose of retrieving and/or



sending files. There are many Internet sites where material or programs can be obtained by using the word *anonymous* when you login. These sites are called *anonymous* FTP servers.

Home Page (or Homepage): (1) The **web page** that your browser is set to use when it starts up; (2) the main web page for a business, school, organization, person; and (3) the main page of an Internet site.

Hypertext: Text (usually colored or underlined) that contains links to other **documents** or sites. Pictures can also be links to other information.

HyperText Markup Language (HTML): The coding language used to create hypertext documents for use on the World Wide Web (WWW). HTML files are meant to be viewed using a web browser such as *Netscape* or *Internet Explorer*.

HyperText Transport Protocol (HTTP): The protocol for moving hypertext (HTML) files across the Internet. *HTTP* is the beginning of a World Wide Web address written as: http://

Internet Relay Chat (IRC): Multi-user live chat. A chat room is an Internet site that allows you to communicate with others. They may be public or private and cover a wide range of topics. **CAUTION:** Be careful who you are "chatting" with as you don't know who they are.

Listserv: The most common kind of mailing list. Users can subscribe to a list and receive messages generated by other members.

Netscape: A WWW Browser and the name of a company.

Network: Two or more computers connected together so that they can share resources. When two or more networks are connected together, it is called an *internet*. Two or more networks connected for company or internal private use is called an *intranet*.



Newsgroup: A bulletin board system that allows users to post messages, ask questions, and receive responses. Newsgroups are classified by specific topic. Messages and replies remain posted for a period of time for reference.

Posting: A single message entered into a newsgroup or e-mail system.

Search Engine: A program that connects you to a database of web sites and Internet resources. Enter a topic or keyword (s) and a search engine will locate databases or listings that may contain the information you are in search of.

Server: A machine on a network that many users access and use to store or retrieve information. A web server houses Internet sites and shares web pages and/or files.

Transmission Control Protocol/Internet Protocol (TCP/IP): This is the protocol that defines the Internet. To be truly on the Internet, your computer must run TCP/IP software.

Telnet: The command/program used to login from one computer to another.

Uniform Resource Locator (URL): The standard way to give the address of any resource on the Internet that is part of the WWW. A URL looks like this: <http://www.yahoo.com> OR <ftp://ftp.netscape.com>

World Wide Web: The entire collection of Internet resources that can be accessed including text, graphics, sound files, etc., using web browsing software.

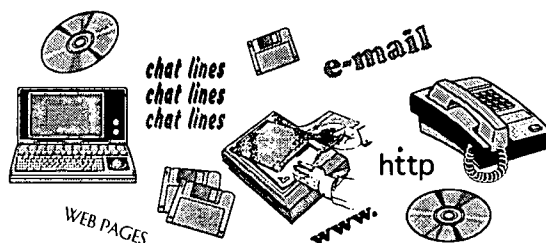



Search Engines: How to Find a Needle in a Haystack

The Internet gives you access to an ever-growing wealth of information. In many of your research projects, you will want to be able to search this huge bank of knowledge and select relevant information. There is a vast amount of information available online, some of it accurate and relevant, some of it not, and you need to be able to recognize the difference.

There is really no one complete Internet reference available. Numerous search engines are available to locate specific information. Different search engines provide different results based on their method of searching. Some search for titles of web pages, others for keywords. It is helpful to try one or more different search engines to compare results and find other relevant locations. Make the task of searching with a search engine easier, by dividing the process into steps.

To locate commonly used search engines, you can choose *Net Search* on the **button bar** of the *browser window*. This will connect you to a **menu** of search engines. Be patient, as this site can sometimes be very busy. The URLs of these search engines and other directories have been provided below. To connect to any of the following search engines below, type in the complete URL in the location line of your *browser* and then press *enter*. There are many other searches that are available, and some are tailored to specific needs such as images, phone numbers, or maps. Some of the most common search engines are as follows:

Netscape Search: <http://home.netscape.com/home/internet-search.html>

Infoseek Search: <http://guide.infoseek.com>

Lycos Search Engine: <http://a2z.lycos.com>

Webcrawler Searching: <http://webcrawler.com/>

W3 Search Engines: <http://www.w3.org/pub/DataSources/WWW/Servers.html>

Yahoo Internet Directory: <http://www.yahoo.com/>

WWW Virtual Library: <http://www.w3.org/hypertext/DataSources/bySubject/Overview.html>



Excite: <http://www.excite.com>

Magellan: <http://www.mckinley.com>

Alta Vista: <http://altavista.digital.com/>

Yahooligans: <http://www.yahooligans.com>

WhoWhere?: <http://www.whowhere.com> (locates people on the Internet by name or initials)



Practice

Browse using a search engine and locate the URLs (Uniform Resource Locators) for the following types of sites. You can find any example that fits the following site category.

educational: _____

entertainment: _____

college or university: _____

general reference site: _____

government: _____

commercial: _____

*List the **addresses** (URLs) for the following sites. (Use Net Search to help locate them.)*

Rock Mall: _____

the NFL: _____

the White House: _____

MTV: _____



Internet Searching and Boolean Wording: Narrowing Your Search

1. Identify a general topic or keyword. Start with a general word or topic and then get specific. (**Example:** Begin with the general topic *wars* then *Vietnam*.) Identify other terms or synonyms that can be used to describe this topic. Use a subject catalog or directory (like Yahoo) to find the general area.
2. Use **Boolean wording** to narrow down your search.
 - To locate multiple words use **AND**. The **AND** will look for titles or keywords that contain all of the words specified. (**Example:** To find information on Florida Panthers, an endangered species, try searching for "Florida **AND** Panther.")
 - To locate items that may have multiple names or spellings use **OR**. The **OR** will look for titles or keywords that contain either of the words specified. (**Example:** To find information on e-mail, try searching for "email **OR** e-mail")
 - To eliminate unwanted references use **NOT**. The **NOT** will eliminate unwanted references that include the word you do not want. (**Example:** To find information on panthers [an endangered species, **NOT** the hockey team], try "panthers **NOT** hockey.")
 - As you get more and more specific in refining your search, use combinations of **AND**, **OR**, and **NOT**. (**Example:** "Florida **AND** Panthers **NOT** hockey.")
3. Try another search engine that uses a different searching technique. Some search engines are better than others when looking for specific information or for certain types of information. Try several and compare your results. Make sure that you read the "search tips" or "help" and understand how to search using that particular search engine. Find out if the search engine uses **AND**, **OR**, and **NOT** or "+" and "-".



panther NOT hockey



Other tips for better searches are listed below:

1. Make sure that your topic is spelled correctly.
2. Capitalize names or proper nouns.
3. Leave out common words and prepositions to narrow your search. Specific or uncommon adjectives help limit your search.
4. Check the way that the search engine you are using works. Can you limit/increase the number of "hits" or references returned? Does the search engine accept Boolean searching terms or does it use another search method?
5. Analyze your results and then refine your search. Are you getting too few or too many results? Do you need to be more specific or general in your search? Would it make sense to use a directory or list search to narrow down your topic or search within a category?
6. Try another search engine with the same keywords.
7. Be patient. It sometimes takes time to find specific information.

Tips for Better Searches

<input type="checkbox"/>	✓	<i>check spelling</i>
<input type="checkbox"/>	✓	<i>capitalize names or proper nouns</i>
<input type="checkbox"/>	✓	<i>narrow your search</i>
<input type="checkbox"/>	✓	<i>check how the search engine works</i>
<input type="checkbox"/>	✓	<i>refine your search</i>
<input type="checkbox"/>	✓	<i>try another search engine</i>
<input type="checkbox"/>	✓	<i>be patient</i>



Sending and Receiving Electronic Mail: The Computer Postal Service

One very common and valuable use of the Internet is the sending and receiving of electronic mail, or e-mail. E-mail is very similar to the kind of mail you send by way of the U.S. Postal Service. You have an address at which you receive mail and you send mail to others at their address. You can send or receive a message from any computer that is online to any other computer that is online. One advantage that e-mail has over regular mail, or snail mail, is speed. E-mail travels from one site to another often in a matter of seconds. However, some mail services only send or retrieve mail at periodic intervals and may not be instantaneous.

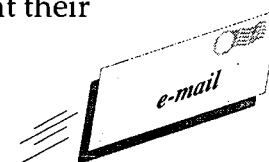

For you to be able to use e-mail, your computer must be set up to use it. See your teacher to make sure your machine has been set up. To send or reply to e-mail, follow the steps below:

1. Get on the Internet using your browser. When you are online, click on the small *envelope* icon in the bottom right-hand corner or click on *mail* under *Window* on the main menu.
2. To see a list of your messages, click on the *Inbox* icon. A list of your messages will appear in the window on the right-side.
3. To see an entire *message*, click on it. The text of the message will appear in the lower window.
4. To reply to message, click the *Re: Mail* icon. This will automatically address your e-mail to the person who sent the message. If you wish to send a message to a list of people, click the *Re: All* icon.
5. Type your message in the new *window* that appears.
6. To create a new message, click on the *To: Mail* button or *new mail* under *File* on your button bar. A new message window will appear.
7. In the *Mail to:* box, enter the address of the person to whom you are sending your message. Then press TAB or click in the *empty message window*. Then type your message in the new window.

8. To send your message, click the *Send* or *Send Now* button on your button bar.
9. To delete a message after reading it, click on the *Delete* button on your button bar. This can also be done by clicking on a message that appears on your list of messages. (See step #2.)

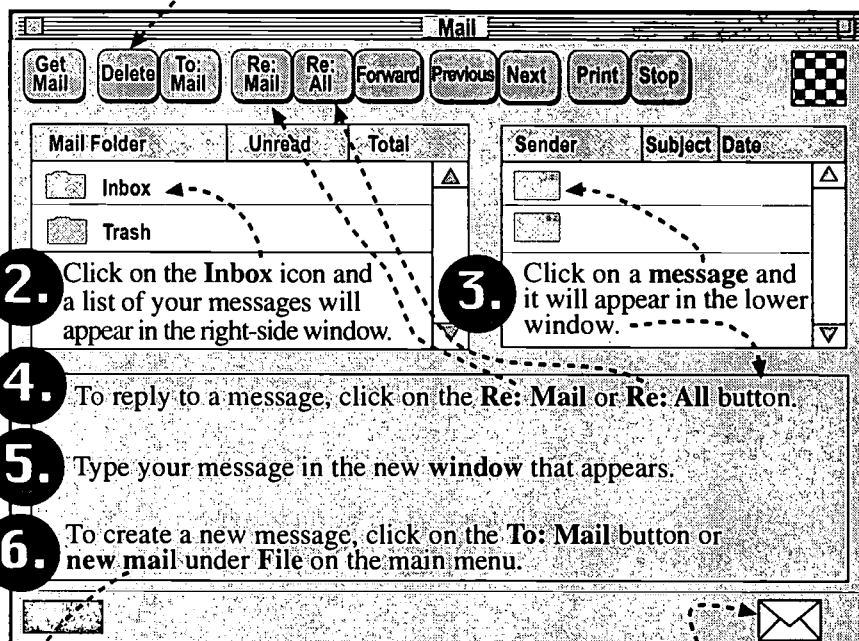

2. Click on the **Inbox** icon and a list of your messages will appear in the right-side window.
3. Click on a **message** and it will appear in the lower window.
4. To reply to a message, click on the **Re: Mail** or **Re: All** button.
5. Type your message in the new window that appears.
6. To create a new message, click on the **To: Mail** button or **new mail** under **File** on the main menu.

1. To open mail click on small **envelope** in the bottom right corner of the window or click on **mail** under **window** to open the mail.

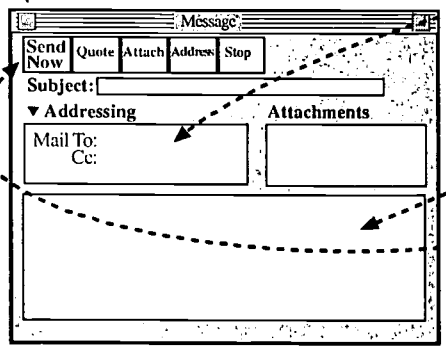
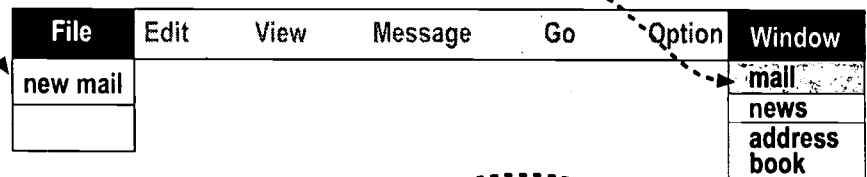

7. In the **Mail To:** box, enter the address of the person to whom you are sending your message. Then press **TAB** or click in the empty **message window**. Then type your message in the new window.
8. To send your message, click the **Send** or **Send Now** button on your Message Window.
9. To Delete a message, after reading it, click on the **Delete** button.



Practice

*Get on the Internet using a browser and establish an **e-mail** account.*

What is your e-mail address? _____

As soon as your account is active, send a short e-mail message about your class to your teacher or the student sitting next to you. Then reply to an e-mail message that you receive.



Citing Electronic References: Giving Credit Where Credit Is Due

It is important to give credit for information from other sources. Internet and electronic references or sources are no different from other reference materials except that they are constantly changing. One of the major reasons to cite references is to be able to locate the information again. When citing a reference, it is important to obtain the following information: author's (or authors') name (first and last), title of document, title of complete work (if available), complete address of site, and document date or latest revision.

The screenshot shows a Netscape browser window with the title bar "Netscape: Hot Air Balloon". The address bar contains "http://www.Hotairballoons.com". The main content area has a title "Hot Air Balloons" in a large, stylized font. Below the title is a date "10/12/97" and a section titled "Flying Fun". The text under "Flying Fun" describes hot air balloons and mentions that most balloonists prefer to fly just before dusk because there is less wind. It also says you can fly close to the ground, under 400 feet, and see many sights and sounds. Below this text is the author's name "Matt Wind" and a date of revision "5/15/97". At the bottom of the page is the author's e-mail address "http://www.Wind.balloons.html".

Annotations on the right side of the screenshot point to the following elements:

- Title bar of Netscape/Explorer window
- Address of site
- Title of document
- Date document is accessed
- Document date or date of revision
- Author's name
- Author's e-mail address

The MLA style for Citations of Electronic resources is very similar to that for nonelectronic resources. It should include all applicable information from the resource. Document titles should be enclosed in quotation marks, and complete titles should be in italics or underlined. The Internet is not a permanent or static resource, so it is very important to include the date you accessed or received the information and the date of the last revision. It is also helpful if you set your web browser to print the title, address, and date on pages that are printed out for reference, and to print e-mails or listservs that are used.



The following order is used when citing an Internet reference:

Last name of Author, First name of Author. Title of Document. Title of Entire Work (if applicable). Version, if applicable. Document date or revision date (if different from access date). Complete Internet address including path (date of access).

Other types of references, like telnet, **gopher**, or ftp use the same or similar formats. Most of the references used in the classroom will probably be of the following types:

World Wide Web Sites

Last name, First name. Title of document. Complete title of site. Document or revision date (if different from date accessed). Complete Internet address (Date accessed).

Walker, Janice. "Walker/ACW Style Sheet." December 1996.
<http://www.cas.usf.edu/english/walker/mla.html> (13 March 1997).

E-mail, Listserv, and Newsgroup Citations

Last name, First name. Subject of posting or mail. Address or type of communication if personal e-mail (date of access).

Gates, Bill. "Where do you want to go today?" Personal e-mail (1 August 1997).

Smith, Mary. "Welcome to Think Quest."
majordomo@advanced.org (31 December 1996).

CD-ROM References

Last name, First name. "Title of article." Complete title. Version. Copyright date.

Winsberg, Morton D. "Florida Weather." Atlas of Florida. 1994.



FTP (File Transfer Protocol) Site

Last name, First name. "Title." Document date. Complete Internet address (access date).

Wentworth Publishing Co. "ERIC - Language Arts Lesson Plans." 7 May 1997. ftp://ftp.wentworth.com/wentworth/(29 June 1997).

Classroom-Connect/Lessons/NEW%21-ERIC-Plans/
New-Lessons/Language_Arts/Abbreviate.txt (20 May 1997).



Practice

*Get on the Internet using your browser to locate **specific information** on an author (choose one or get a topic from your teacher). Use MLA style to cite the **electronic reference**. You may want to set your browser to print the date and address of the page on the printed document. Use Page Setup under the File Menu.*



Practice

*Get on the Internet and use the **newsgroup** function of your browser (see your teacher for how to set this up) to locate a newsgroup that relates to a specific author. Read some of the postings and reply to one of the articles through e-mail or by posting a response. Set your browser to print the posting and your response.*



Application

*Use the same author/topic as on page 343 and use your browser to locate three more **references**. Write a short paper and use MLA style to cite your **electronic references**.*

Appendices

Index

A

active listening 213, 240
antagonist 247, 263
autobiography 247, 251

B

biography 247, 251
body language 213, 241
Boolean wording 327, 335
button bar 327, 332

C

capitalization 135, 186
character 247, 251
chronological order 85, 116
climax 247, 264
clustering 85, 95
comedy 247, 301
common nouns 135, 170
communication 213, 215
complete sentence 135, 145
conflict 247, 263
connotations 5, 32
copyright 213, 216

D

detail sentences 85, 107
document 327, 330
drama 248, 261

E

editing 135, 145
electronic reference 327, 340
enunciation 213, 224
expository writing 85, 112

F

fiction 248, 251
figurative language 5, 38

G

genres 248, 261
gopher 327, 341
graphic organizer 85, 95

I

index 5, 62
Internet 327, 329
Internet address 327, 329

L

literal language 5, 38
literature 248, 255

M

main idea 5, 35
menu 327, 332
metaphor 5, 38, 248, 289
MLA style 328, 340

N

narrator 248, 265
nonfiction 248, 251
nonverbal communication 213, 225
noun and pronoun agreement 135, 178
nouns 135, 170
novel 248, 251

O

onomatopoeia 5, 38
oral communication 213, 215

P

personification 6, 38, 249, 289
persuasion techniques 214, 231
persuasive writing 85, 112
pitch 214, 224
plot 249, 261
poetry 249, 289
possessives 136, 182
preview 6, 7
pronunciation 214, 224
proofreading 136, 198
proper nouns 136, 170
protagonist 249, 262
punctuation 136, 145

R

revising	136, 137
rhyme	249, 289
rhythm	249, 290
run-on sentence	136, 145

S

search engine	328, 331
setting	249, 251
short story	249, 251
simile	6, 38, 249, 289
subject and verb agreement	136, 160
summary	6, 71
suspense	250, 264

T

table of contents	6, 7
tempo	214, 224
theme	250, 256
topic sentence	85, 107
tragedy	250, 301

U

useful topic	85, 87
--------------------	--------

V

visual aids	214, 216
visual references	6, 43
volume	214, 224

W

web page	328, 330
window	328, 332

References

- Akerman, Diane. *The Moon by Whale Light*. New York: Vintage-Random, 1991.
- Arolimek, John, et al. *World Neighbors*. New York: Macmillan, 1985.
- Applebee, Arthur N., et al. *The Language of Literature*. Evanston, IL: McDougal Littell, 1997.
- Armstrong, Thomas. *Multiple Intelligences in the Classroom*. Alexandria, VA: Association for Supervision and Curriculum Development, 1994.
- Beane, James A., ed. *Toward a Coherent Curriculum*. Alexandria, VA: Association for Supervision and Curriculum Development, 1995.
- Berbrich, Joan D. *Fifteen Steps to Better Writing*. New York: Amsco School Publications, 1988.
- Berbrich, Joan D. *Writing Practically*. New York: Amsco School Publications, 1994.
- Bowler, Ellen, ed. *Prentice-Hall Literature World Masterpieces*. Saddle River, NJ: Prentice-Hall, 1996.
- Christ, Henry I. *Building Power in Writing*. New York: Amsco School Publications, 1992.
- Florida Department of Education. *Florida Curriculum Framework: Language Arts*. Tallahassee, FL: State of Florida, 1996.
- Florida Department of Education. *Florida Writes! Report on the 1996 Assessment*. Tallahassee, FL: State of Florida, 1996.
- Gardner, Lewis, ed. *Scope English Anthology (Level Five)*. New York: Scholastic, 1984.
- Gardner, Lewis, ed. *Scope English Anthology (Level Four)*. New York: Scholastic, 1984.
- Gardner, Lewis, ed. *Scope English Anthology (Level Three)*. New York: Scholastic, 1983.

- Gill, Kent and Jackie Proett. *The Writing Process in Action*. Urbana, IL: National Council of Teachers of English, 1986.
- Golub, Jeff, et al. *Activities to Promote Critical Thinking*. Urbana, IL: National Council of Teachers of English, 1986.
- Harmin, Merrill, *Inspiring Active Learners: A Handbook for Teachers*. Alexandria, VA: Association for Supervision and Curriculum Development, 1994.
- Hutchinson, Jamie, ed. *Teaching Literature in High School: The Novel*. Urbana, IL: National Council of Teachers of English, 1995.
- Hutchinson, Jamie, ed. *Teaching the Writing Process in High School*. Urbana, IL: National Council of Teachers of English, 1995.
- Johnson, Elaine, ed. *American Literature for Life and Work*. Cincinnati, Ohio: South-Western Educational Publishing, 1997.
- Kaiman, Amy Bunin. *Florida's HSCT: Preparing for the Communications Test*. New York: Amsco School Publications, 1996.
- Kaiman, Amy Bunin. *Preparing for the Florida Writing Assessment Test, Secondary Level*. New York: Amsco School Publications, 1997.
- Krenzke, Lois, et al. *Writers INC*. Boston: D.C. Heath, 1996.
- Langer, Judith, ed. *Literature Instruction: A Focus on Student Response*. Urbana, IL: National Council of Teachers of English, 1986.
- Lloyd-Kolkin, Donna and Kathleen R. Tyner. *Media and You*. Englewood Cliffs, NJ: Strategies for Media Literacy, 1991.
- National Council of Teachers of English and International Reading Association. *Standards for the English Language Arts*. Urbana, IL: National Council of Teachers of English, 1995.
- Noguchi, Rei R. *Grammar and the Teaching of Writing*. Urbana, IL: National Council of Teachers of English, 1991.
- Oliver, Eileen Iscoff. *Crossing the Mainstream: Multicultural Perspectives in Teaching Literature*. Urbana, IL: National Council of Teachers of English, 1994.

Oliver, Eileen Iscoff. *Crossing the Mainstream: Multicultural Perspectives in Teaching Literature*. Urbana, IL: National Council of Teachers of English, 1994.

Schumaker, Jean B. and Jan Sheldon. *The Sentence Writing Strategy*. Lawrence, KS: The University of Kansas, 1985.

Sebranek, Patrick, et al. *Write Source 2000*. Boston: D. C. Heath, 1995.

Snow, Robert A. *Advanced Reading Skills*. New York: Amsco School Publications, 1994.

Sorenson, Sharon. *Composition: Prewriting, Response, Revision*. New York: Amsco School Publications, 1994.

Tachudi, Stephen. *Planning and Assessing the Curriculum in English Language Arts*. Alexandria, VA: Association for Supervision and Curriculum Development, 1991.

Production Software

Adobe PageMaker 6.0. Mountain View, CA: Adobe Systems.

Adobe Photoshop 3.0. Mountain View, CA: Adobe Systems.

Macromedia Freehand 5.0. San Francisco: Macromedia.

Microsoft Word 5.0. Redmond, WA: Microsoft.

The editors have made every effort to trace the ownership of all copyrighted selections found in this book and to make full acknowledgment for their use. Omissions brought to our attention will be corrected in a subsequent edition.



**Florida Department of Education
Charlie Crist, Commissioner**

5185.B

457.



*U.S. Department of Education
Office of Educational Research and Improvement (OERI)
National Library of Education (NLE)
Educational Resources Information Center (ERIC)*



NOTICE

Reproduction Basis



This document is covered by a signed "Reproduction Release (Blanket)" form (on file within the ERIC system), encompassing all or classes of documents from its source organization and, therefore, does not require a "Specific Document" Release form.



This document is Federally-funded, or carries its own permission to reproduce, or is otherwise in the public domain and, therefore, may be reproduced by ERIC without a signed Reproduction Release form (either "Specific Document" or "Blanket").

EFF-089 (5/2002)